

# eMotion NT2:3

## Product Specification

This document might be changed without prior notice

12033811 eMotionNT2:3 – LVDS

12033626 eMotionNT2:3 – eDP

Revision: 002

Date: 2022-06-27

## Revision History

Rev.	Date	Author	Modifications
000	08.01.2019	R. Muhler	Initial revision
001	22.07.2020	M. Schmidt	Chapter 3: connector pitch data removed, Chapter 5.2:EMI standards actualized
002	27.06.2022	R. Muhler	Operating temperature range extended to -20° - +70° after internal qualification (Chapter 5.1)
002			
003			

Change History (Optional)

## Table of contents

<b>1. Preamble.....</b>	<b>5</b>
1.1. <i>Purpose of this document</i> .....	5
1.2. <i>Abbreviations</i> .....	5
<b>2. Product description .....</b>	<b>6</b>
2.1. <i>Functionally description of the product</i> .....	6
2.2. <i>Special Features</i> .....	6
2.3. <i>Variants of eMotionNT2:3</i> .....	6
<b>3. PCB description .....</b>	<b>7</b>
3.1. <i>Dimensions of eMotionNT2:3</i> .....	7
3.2. <i>Connector overview</i> .....	8
3.3. <i>Power connector, J1</i> .....	9
3.4. <i>Alternative power connector, J101</i> .....	9
3.5. <i>AUX power connector, J8</i> .....	10
3.6. <i>Power out connector, J2</i> .....	10
3.7. <i>Display-Port input connector, J7</i> .....	11
3.8. <i>DVI-I input connector, J6</i> .....	12
3.9. <i>eDP output connector, J3</i> .....	13
3.10. <i>LVDS output connector, J3</i> .....	14
3.11. <i>Backlight Supply Voltage, J5</i> .....	15
3.12. <i>OSD-Keyboard-Connector, J4</i> .....	15
3.13. <i>I2S-Audio Connector, J100</i> .....	16
3.14. <i>RS232-connector 4pin, CN109</i> .....	16
<b>4. Technical Details .....</b>	<b>17</b>
4.1. <i>Block diagram</i> .....	17
4.2. <i>Supply voltages and current consumption</i> .....	17
4.3. <i>Configuration Options on eMotionNT2:3</i> .....	18
4.4. <i>TCON-current capability of eMotionNT2:3</i> .....	18
4.5. <i>Backlight-current capability of eMotionNT2:3</i> .....	18
4.6. <i>Input and output signals</i> .....	19
4.6.1st DP input .....	19
4.6.2nd DVI input .....	19
4.6.3rd LVDS connector .....	19
4.7. <i>Serial Communication with eMotionNT2:3</i> .....	20
4.8. <i>Firmware Update on eMotionNT2:3</i> .....	20
<b>5. Qualification.....</b>	<b>21</b>
5.1. <i>Environmental conditions</i> .....	21
5.2. <i>EMI-Standards</i> .....	21
5.3. <i>Safety</i> .....	21

- 5.4. *Shock and Vibration*.....22
- 5.5. *Reliability, MTBF*.....22
- 6. Warranty, Quality and Environmentalism .....22**
  - 6.1. *Warranty*.....22
  - 6.2. *Quality*.....22
  - 6.3. *Environmentalism*.....22
- 7. Label and package.....23**
  - 7.1. *Label and material number* .....23

# 1. Preamble

## 1.1. Purpose of this document

The purpose of this document is the definition of the technical parameters, the electrical connections and the mechanical dimensions for the development of the eMotionNT2:3-board.

## 1.2. Abbreviations

I <sup>2</sup> C	INTER-IC
EMI	ELECTRO MAGNETIC INTERFERENCE
EMC	ELECTRO MAGNETIC COMPATIBILITY
EN	EUROPEAN NORM
ESD	ELECTRO STATIC DISCHARGE
UL	UNDERWRITER LAB
PCB	PRINTED CIRCUIT BOARD
SMT	SURFACE MOUNT TECHNOLOGY
ROHS	RESTRICTION FOR THE USE OF HAZARDOUS SUBSTANCES
NC	NOT CONNECTED
T.B.D.	TO BE DEFINED
TMDS	TRANSITION MINIMIZED DIFFERENTIAL SIGNALING
DVI	DIGITAL VIDEO INTERFACE
DP	DISPLAY PORT
EDP	EMBEDDED DISPLAY PORT
OSD	ON SCREEN DISPLAY
DPMS	DISPLAY POWER MANAGEMENT SIGNALING
VESA	VIDEO ELECTRONICS STANDARDS ASSOCIATION
DDC / CI	DISPLAY DATA CHANNEL / COMMAND INTERFACE
VGA	VIDEO GRAPHICS ARRAY
UXGA	ULTRA EXTENDED GRAPHICS ARRAY
USB	UNIVERSAL SERIAL BUS

## 2. Product description

### 2.1. *Functionally description of the product*

Based on the latest design of highly integrated LCD controller NT68862, the eMotionNT2:3 board is able to control panels from VGA up to WUXGA. The eMotionNT2:3-LVDS (12033811) can drive panels with LVDS interface.

The eMotionNT2:3-eDP (12033626) can drive panels with eDP interface.

The eMotionNT2:3 graphic controller board can be connected to input signals coming from DP and DVI-I sources.

The board can be controlled by a 5-key OSD keyboard and IR-controller.

The interface board is compatible with VESA DPMS, DDC2B, DDC/ CI and can be controlled by RS232.

### 2.2. *Special Features*

- DP 1.2 compliant input (HBR)
- DVI-I (analog 205MHz / digital 165MHz)
- Up to WUXGA with 170MHz to the panel (8bit)
- 10-bit color processing
- Built in backlight control for up to 6A backlight current
- Built in power on/off sequencing controller for panel power
- Support of 3.3V, 5.0V, 12V\* panel voltage and 12V/ 24V\* backlight voltage
- Multilingual OSD
- Panel file in separate EEPROM (option)

\*: 12V panel voltage and 24V backlight voltage are only available if input voltage is 24V!

### 2.3. *Variants of eMotionNT2:3*

Due to connectors footprint and pin arrangement it is not possible to have LVDS-out and eDP-out on the same layout by mounting options.

To drive TFTs with LVDS-input or eDP-input there are 2 variants of eMotionNT2:3 with different layout necessary!

The variants are called as following:

- eMotionNT2:3-LVDS (Hirose connector DF14-30P-1.25H is mounted on J3)
- eMotionNT2:3-eDP (JAE connector FI-RE41S-HF is mounted on J3)

The differences between these variants are very small and can be seen in next chapter

### 3. PCB description

#### 3.1. Dimensions of eMotionNT2:3

Dimensions of both variants: 96mm (L) x 96mm (W) x 17mm (H). Mounting holes diameter: 4 x 3.5mm

(Remark: The dimensions of eMotionNT2:3 (both variants) are the same as of eMotionST2:3. Most of the connectors will have the same position as on the eMotionST2:3)

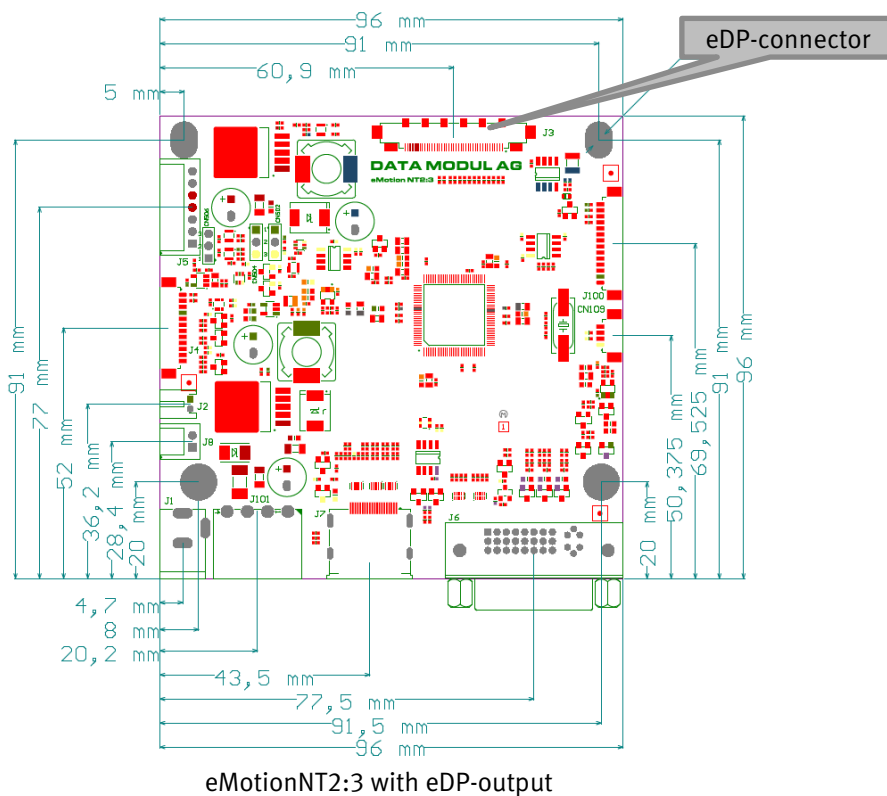
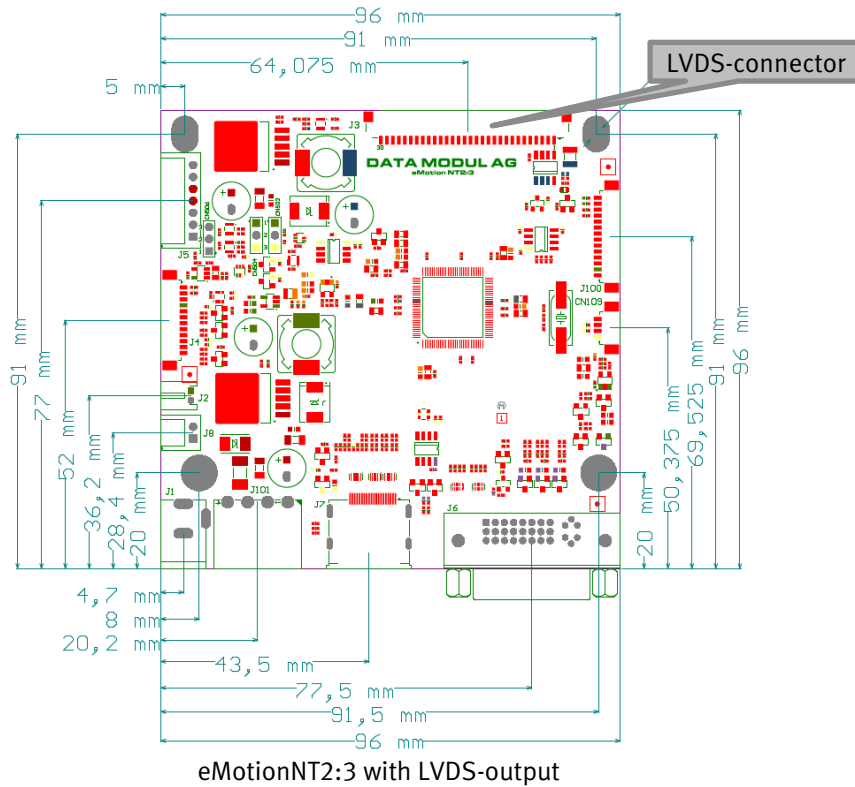

3.2. Connector overview

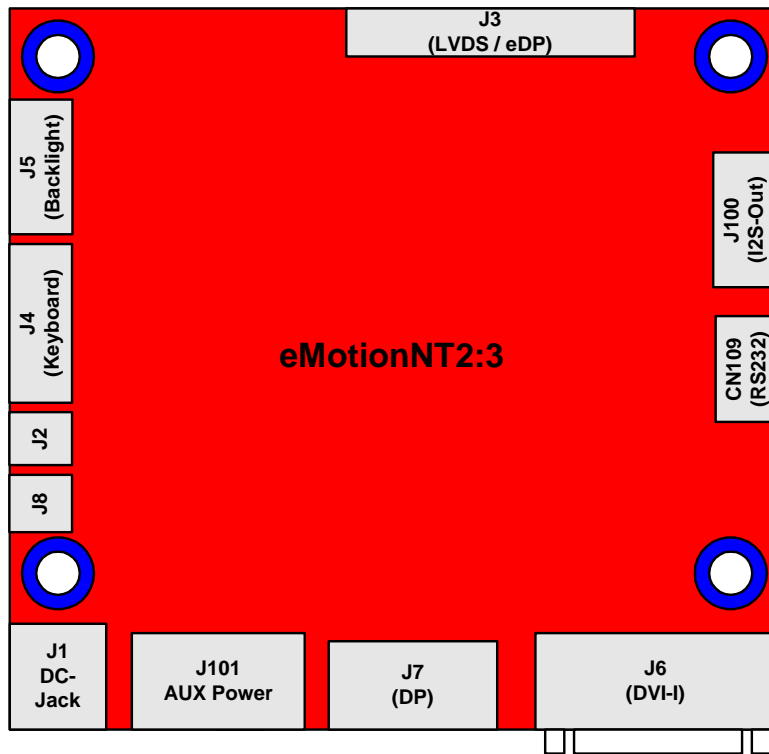

Item	Description	Remark
J1	Power connector	DC-Jack , 2.5mm max 5A
J2	Power out	2pin, 5V power output, max 100mA
J3	LVDS Dual link out / eDP (4 lanes)	30pin (LVDS) resp. 41pin (eDP), Display Interface Connector
J4	External OSD connector	12pin, OSD, IR, LED, etc.
J5	Inverter / Backlight connector	7pin, Power supply / dimming Note: inverter input voltage must fit to the input voltage of the board
J6	DVI-I Input	24+5pin DVI-I connector female
J7	DP Input	20pin, DP connector
J8	AUX power connector	2pin connector, max 3A
J100	I2S Audio	14 pin I2S Audio
J101	Alternative power connector	4pin connector, max 5A
CN109	RS232	4pin, LVTTTL signal level



**3.3. Power connector, J1**

Type: W+P Products, W+P-No.: 649-2-2.5-20-5A, or equivalent

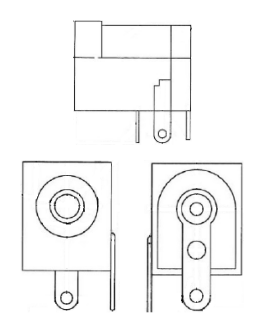
Pin arrangement	Pin	Signal	I/O	Description
 <p>Side-,Front-, Rear-View</p>	1	+Vin	I	+12V/5A or +24V/5A
	2	GND	I/O	GND / 5A
	3	GND	I/O	GND / 5A

**3.4. Alternative power connector, J101**

Type: Molex-Ref.-No: 0039303045, or equivalent

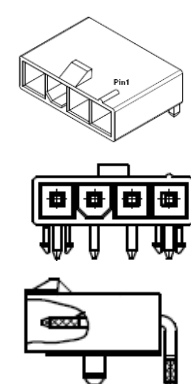
Pin arrangement	Pin	Signal	I/O	Description
 <p>Top- Front-, Side-View</p>	1	GND	I/O	GND
	2	GND	I/O	GND
	3	+Vin	I	+12V/4A* or +24V/4A*
	4	+Vin	I	+12V/4A* or +24V/4A*

\* 4A per pin / max 5A on connector

**3.5. AUX power connector, J8**

Type: JST-Ref.-No. S2B-EH, or equivalent

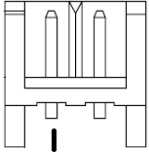
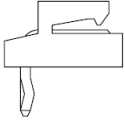
Pin arrangement	Pin	Signal	I/O	Description
 <p>Pin 1</p> <p>Top view</p>  <p>Side view</p>	1	+Vin	O	+12V/3A or +24V/3A
	2	GND	I/O	GND

**3.6. Power out connector, J2**

Type: JST-Ref.-No. S2B-PH-K-S, or equivalent

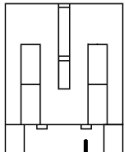
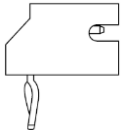
Pin arrangement	Pin	Signal	I/O	Description
 <p>Pin 1</p> <p>Top view</p>  <p>Side view</p>	1	+5V	O	+5V DC $\pm$ 5%, 100mA
	2	GND	I/O	GND

**3.7. Display-Port input connector, J7**

Type: W+P: 8470-2-2-1-80-TR, or equivalent

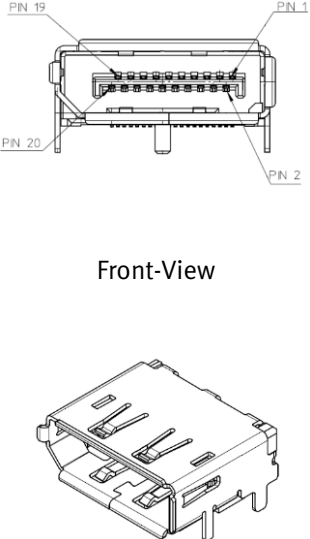
Pin arrangement	Pin	Signal	I/O	Description
 <p>Front-View</p>	1	ML_L3N	I	Main Link Ch. 3 Differential Input negative
	2	GND	I/O	Ground
	3	ML_L3P	I	Main Link Ch. 3 Differential Input positive
	4	ML_L2N	I	Main Link Ch. 2 Differential Input negative
	5	GND	I/O	Ground
	6	ML_L2P	I	Main Link Ch. 2 Differential Input positive
	7	ML_L1N	I	Main Link Ch. 1 Differential Input negative
	8	GND	I/O	Ground
	9	ML_LN1P	I	Main Link Ch. 1 Differential Input positive
	10	ML_LN0N	I	Main Link Ch. 0 Differential Input negative
	11	GND	I/O	Ground
	12	ML_LN0P	I	Main Link Ch. 0 Differential Input positive
	13	Config 1	O	Config Pin1, connect to GND with 1M
	14	Config 2	O	Config Pin2, connect to GND with 1M
	15	AUXP	I	Auxiliary Ch. Differential Input positive
	16	DP_IN.DET	I	Detect pin for cable connection
	17	AUXN	I	Auxiliary Ch. Differential Input negative
	18	HPD	I/O	Hot Plug Detect
	19	POR	I/O	Connected to Ground
	20	PO	O	Not connected to internal circuits

**3.8. DVI-I input connector, J6**

Type: DVI-socket W+P: 507-29-2-2-20, or equivalent

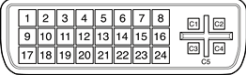
Pin arrangement	Pin	Signal	I/O	Description
 <p>Front view</p>	1	DT2-	In	TMDS Data2-
	2	DT2+	In	TMDS Data2+
	3	TX2/4-SHLD	I/O	TMDS Data2 Shield (Ground)
	4	N.C.		
	5	N.C.		
	6	DDC-CLK	In	I2C-Clock, +5V level
	7	DDC-Data	I/O	I2C-Data, +5V level
	8	AVS	In	Analog Vertical Sync
	9	DT1-	In	TMDS Data1-
	10	DT1+	In	TMDS Data1+
	11	TX1/3-SHLD	I/O	TMDS Data1 Shield (Ground)
	12	N.C.		
	13	N.C.		
	14	+5V	In	+5V Power*
	15	Ground (for +5V)	I/O	
	16	HP Detect	Out	Hot Plug Detect
	17	DT0-	In	TMDS Data0-
	18	DT0+	In	TMDS Data0+
	19	TX0/5-SHLD	I/O	TMDS Data0 Shield (Ground)
	20	N.C.		
	21	N.C.		
	22	TXC-SHLD	I/O	TMDS Clock Shield (Ground)
	23	CLK+	In	TMDS Clock +
	24	CLK-	In	TMDS Clock -
	C1	ARED	In	Analog Red
	C2	AGRN	In	Analog Green
	C3	ABLU	In	Analog Blue
	C4	AHS	In	Analog Horizontal Sync
	C5	GND	I/O	Analog RGB Ground

3.9. eDP output connector, J3

Type: JAE FI-RE41S-HF, 41pin, SMT, right angle, or equivalent

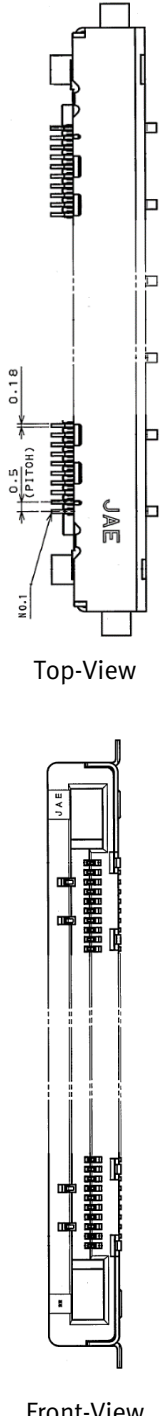
Pin arrangement	Pin	Signal	I/O	Description
 <p>Top-View</p> <p>Front-View</p>	1	NC - RESERVED		Reserved for LCD manufacturer's use
	2	GND	I/O	Ground
	3	EDP_L3_N	0	eDP data lane3 negative
	4	EDP_L3_P	0	eDP data lane3 positive
	5	GND	I/O	Ground
	6	EDP_L2_N	I/O	eDP data lane2 negative
	7	EDP_L2_P	0	eDP data lane2 positive
	8	GND	I/O	Ground
	9	EDP_L1_N	0	eDP data lane1 negative
	10	EDP_L1_P	0	eDP data lane1 positive
	11	GND	I/O	Ground
	12	EDP_L0_N	0	eDP data lane0 negative
	13	EDP_L0_P	0	eDP data lane0 positive
	14	GND	I/O	Ground
	15	AUX_CH_P	I/O	Auxiliary Channel positive
	16	AUX_CH_N	I/O	Auxiliary Channel negative
	17	GND	I/O	Ground
	18	Panel VCC*	0	Panel VCC
	19	Panel VCC*	0	Panel VCC
	20	Panel VCC*	0	Panel VCC
	21	Panel VCC*	0	Panel VCC
	22	NC		No connection
	23	GND	I/O	Ground
	24	GND	I/O	Ground
	25	GND	I/O	Ground
	26	GND	I/O	Ground
	27	HPD	I/O	HPD signal pin
	28	GND	I/O	Ground
	29	GND	I/O	Ground
	30	GND	I/O	Ground
	31	GND	I/O	Ground
	32	B_EN	0	Backlight On/Off (Optional)
	33	B_PWM	0	PWM diming output
	34	B_ADIM	0	Analog diming output
	35	NC - RESERVED		Reserved for LCD manufacturer's use
	36	BLT_VCC**	0	Backlight power
	37	BLT_VCC**	0	Backlight power
	38	BLT_VCC**	0	Backlight power
	39	BLT_VCC**	0	Backlight power
	40	NC - RESERVED		RESERVED for LCD manufacturer's use
	41	NC		No connection

\* Note: Pin18, 19, 20, 21: Output voltage 3.3V / 5.0V / 12.0V – selected by firmware

\*\* Note: BLT\_VCC follows the board supply voltage (+12V or +24V). Board supply should always match with the inverter supply voltage!

3.10. LVDS output connector, J3

Type: Hirose-Ref.-No. DF14-30P-1.25H, (YEON-HO 12507WR-30), or equivalent

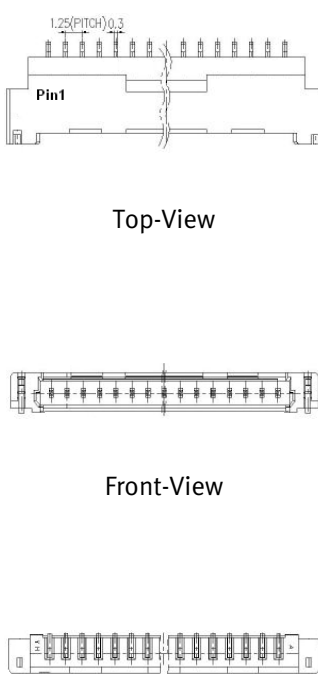
Pin arrangement	Pin	Signal	I/O	Description
 <p>Top-View</p> <p>Front-View</p> <p>Rear-View</p>	1	Panel VCC*	0	Panel VCC
	2	Panel VCC*	0	Panel VCC
	3	Panel VCC*	0	Panel VCC
	4	Panel VCC*	0	Panel VCC
	5	GND	I/O	Ground
	6	REVERSE_SCAN	0	Digital out (3V3 or 0V)
	7	GND	I/O	Ground
	8	TXA3_P	0	TX3 odd positive
	9	TXA3_N	0	TX3 odd negative
	10	TCLKA_P	0	Clock odd positive
	11	TCLKA_N	0	Clock odd negative
	12	TXA2_P	0	TX2 odd positive
	13	TXA2_N	0	TX2 odd negative
	14	GND	I/O	Ground
	15	TXA1_P	0	TX1 odd positive
	16	TXA1_N	0	TX1 odd negative
	17	TXA0_P	0	TX0 odd positive
	18	TXA0_N	0	TX0 odd negative
	19	GND	I/O	Ground
	20	TXB3_P	0	TX3 even positive
	21	TXB3_N	0	TX3 even negative
	22	TCLKB_P	0	Clock even positive
	23	TCLKB_N	0	Clock even negative
	24	TXB2_P	0	TX2 even positive
	25	TXB2_N	0	TX2 even negative
	26	GND	I/O	Ground
	27	TXB1_P	0	TX1 even positive
	28	TXB1_N	0	TX1 even negative
	29	TXB0_P	0	TX0 even positive
	30	TXB0_N	0	TX0 even negative

\* Note: Pin1, 2, 3, 4: Output voltage 3.3V / 5.0V / 12.0V – selected by firmware

**3.11. Backlight Supply Voltage, J5**

Type: JST-Ref.-No. S7B-EH, or equivalent

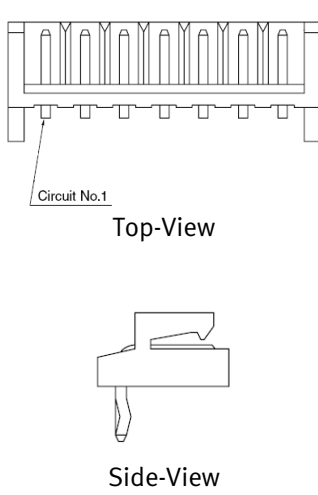
Pin arrangement	Pin	Signal	I/O	Description
 <p>Top-View</p> <p>Side-View</p>	1	ADIM	O	Analog dimming voltage
	2	PWM	O	PWM diming output
	3	EN	O	Backlight ON/OFF
	4	BLT_VCC*	O	Backlight power
	5	BLT_VCC*	O	Backlight power
	6	GND	I/O	Ground
	7	GND	I/O	Ground

\* Note: BLT\_VCC follows the board supply voltage (+12V or +24V). Board supply should always match with the inverter supply voltage!

**3.12. OSD-Keyboard-Connector, J4**

Type 53261-1271 by Molex, SMT Side entry type, 12pin, or equivalent

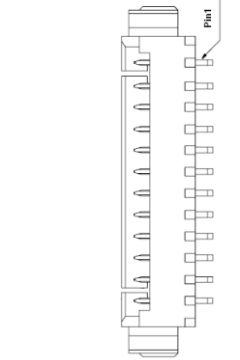
Pin arrangement	Pin	Signal	I/O	Description
	1	LED1	O	LED Green
	2	LED2	O	LED RED
	3	IR	I	IR remote / not connected
	4	Vcc	O	5V
	5	GND	I/O	Ground
	6	SW3	I	Button3 (UP)
	7	SW2	I	Button2 (DOWN)
	8	SW4	I	Button4 (SELECT)
	9	SW6	I	Button6 (POWER)
	10	SW1	I	Button1 (MENU)
	11	SW5	I	Button5 (SPECIAL)
	12	GND	I/O	Ground

**3.13. I2S-Audio Connector, J100**

Type: MOLEX: 53261-1471, SMT Side entry type, 14pin, or equivalent

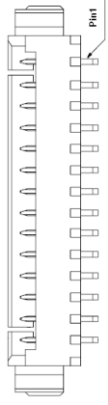
Pin arrangement	Pin	Signal	I/O	Description
 <p>Top view</p>	1	GND	I/O	Ground
	2	5V	0	Power
	3	I2S_WS	0	I2S Word Select
	4	GND	I/O	Ground
	5	I2S_Data	0	I2S Data
	6	GND	I/O	Ground
	7	I2S_BCLK	0	I2S Clock
	8	GND	I/O	Ground
	9	I2S_MCLK	0	I2S MCLK
	10	GND	I/O	Ground
	11	MUTE	0	MUTE
	12	AUDIO_GPIO	I/O	GPIO
	13	I2C SDA	I/O	I2C SDA (3V3 level)
	14	I2C SCL	0	I2C SCL (3V3 level)

**3.14. RS232-connector 4pin, CN109**

Type: Molex: 53261-0471 or YEONHO: 12505WR-04, SMT Side entry type, 4pin, or equivalent

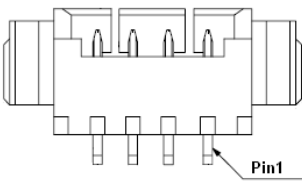
Pin arrangement	Pin	Signal	I/O	Description
 <p>Top-View</p>	1	DVDD33	0	3.3V
	2	UART_EXT.TxD	0	Transmit Data (LVTTTL)
	3	UART_EXT.RxD	I	Receive Data (LVTTTL)
	4	GND	I/O	Ground



## 4. Technical Details

### 4.1. Block diagram

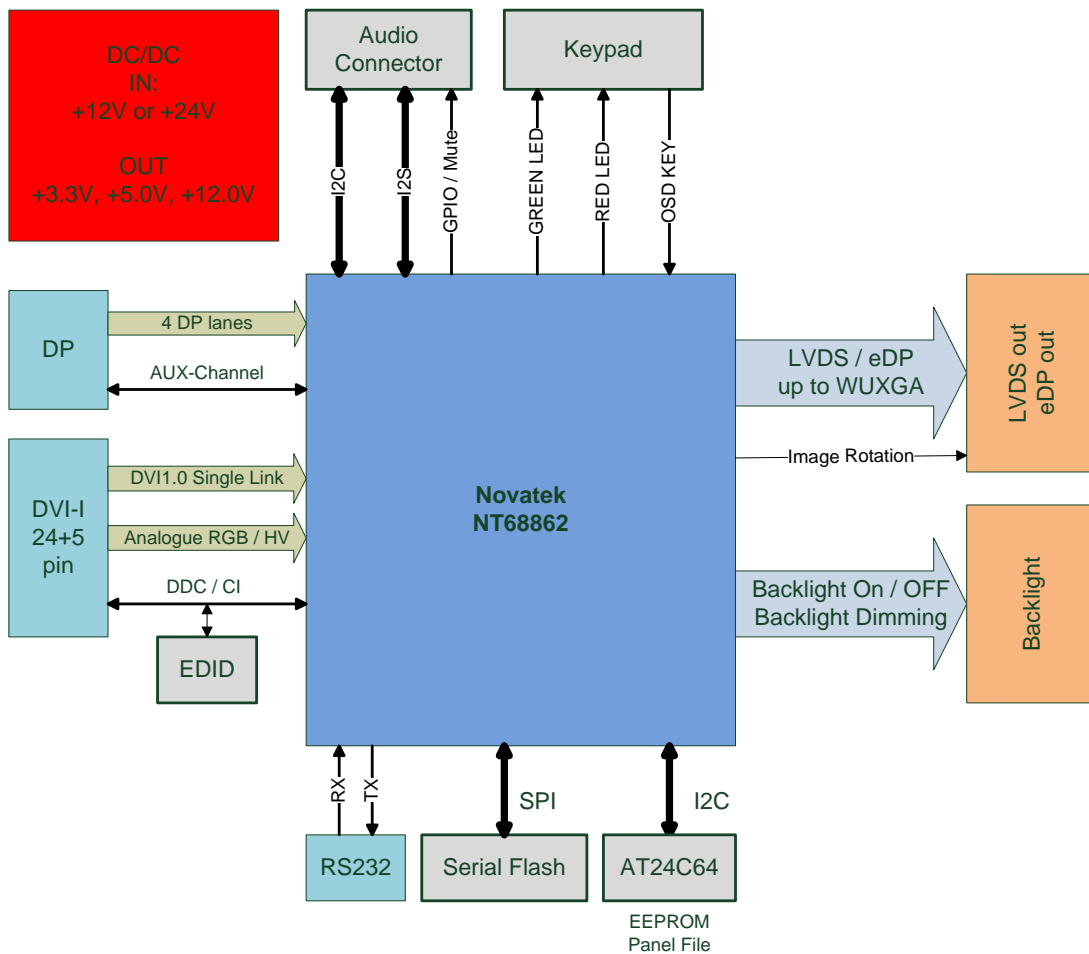

eMotionNT2:3 Block Diagram

### 4.2. Supply voltages and current consumption

The eMotionNT2:3 can handle 12V or 24V DC input voltage. The inverter output voltage (J5) is always equivalent to the DC input voltage of the eMotionNT2:3 (J5). The board is designed for a single power supply. All other supply voltages are generated on the eMotionNT2:3.

Note: The backlight inverter must fit to the input voltage.

Supply voltage	Nominal value	Regulation	Ripple & noise	Onboard current consumption
+12V	+12V	+/-10%	0.3V	200mA max.
+24V	+24V	+/-10%	0.3V	100mA max.

**4.3. Configuration Options on eMotionNT2:3**

eMotionNT2:3 can drive panels with different values for TCON-supply-voltage. Additionally backlight inverters with different values for backlight PWM-voltage / backlight enable-voltage and backlight logic-level can be driven.

Values for TCON-supply-voltage / backlight PWM-voltage and backlight enable voltage will be set by firmware on eMotionNT2:3! I.e. to ensure functionality of connected TFT it is necessary to program the correct firmware on eMotionNT2:3 first!

Possible adjustments:

Value	Can be set to...		
TCON-supply-voltage	+3V3	+5V	+12V
Backlight PWM-voltage	+3V3	+5V	
Backlight enable voltage	+3V3	+5V	
Backlight enable-logic-level	Active high (default)	Active low (mounting option)	

**4.4. TCON-current capability of eMotionNT2:3**

eMotionNT2:3 can deliver the following supply currents to a connected TCON-board

TCON Voltage	Nominal value	Max Current (total)	Ripple & noise
+3V3	3V3	3A	0.1V
+5V	5V	3A	0.1V
+12V	12V	3A	0.1V

TCON-voltage is supplied to TCON-board by pins with signal Panel VCC on J3

**4.5. Backlight-current capability of eMotionNT2:3**

Max. backlight supply current is limited by minimum of current capability of pins with signal BLT\_VCC on J5 (=6A, 3A max. per pin) and maximum current capability at power input less current for TCON- and onboard- consumption.

4.6. *Input and output signals*

4.6.1st DP input

PARAMETER	MIN	TYP	MAX	UNIT	Remark
Peak-to-peak input differential voltage	0.12		1.4	V <sub>p-p</sub>	
Rx DC Common Mode Voltage	0		V <sub>DD</sub>	V	
R <sub>T</sub> Termination Resistance	45	50	55	Ohm	

4.6.2nd DVI input

PARAMETER	MIN	TYP	MAX	UNIT	Remark
Termination Supply Voltage AV <sub>CC</sub>	3,135	3.3	3,465	V	
Differential Input Voltage	150		1200	mV	
Input Common Mode Voltage	AV <sub>CC</sub> -300		AV <sub>CC</sub> -37	mV	
Input Clock frequency	20		165	MHz	

4.6.3rd LVDS connector

PARAMETER	MIN	TYP	MAX	UNIT	Remark
Differential Output Voltage	300	500	700	mV	
Common Mode Voltage		1.25		V	
Clock Frequency			100 90	MHz	Single Channel Dual Channel

**4.7. Serial Communication with eMotionNT2:3**

The eMotionNT2:3 can be controlled by RS232 commands which can be send by COM-port of PC e.g..

RS232-signals RxD and TxD at CN109 should have LVTTTL-level.

⇒ External level converter is necessary:

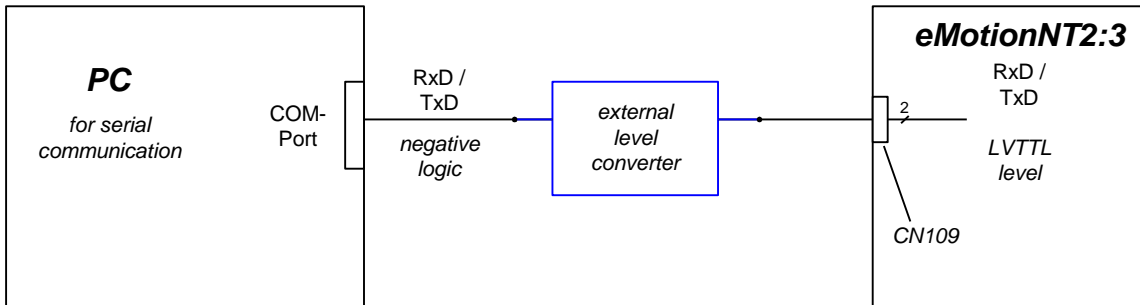

**4.8. Firmware Update on eMotionNT2:3**

Firmware update on eMotionNT2:3 is done over DDC-channel of video-input DVI. An USB-ISP Board is necessary for this operation!

This board is connected to PC with USB2.0 cable and to eMotionNT2:3 with normal video cable to DVI-input.

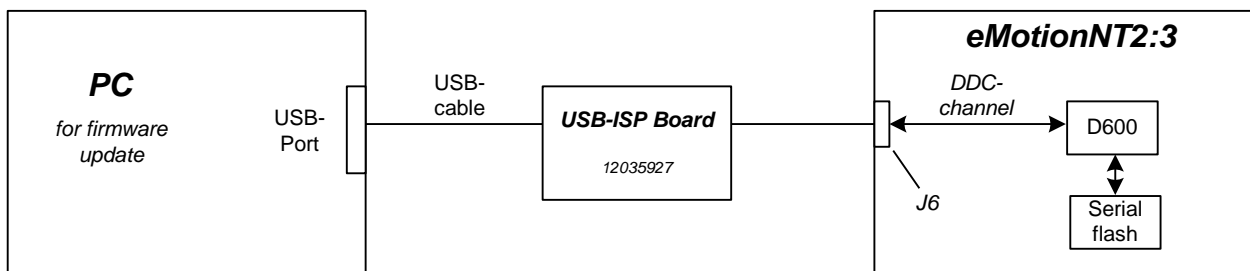

Details for firmware update on request.

## 5. Qualification

### 5.1. Environmental conditions

Parameter	Min	Max
Operating temperature	-20°C	+70°C
Storage temperature	-20°C	+80°C
Relative humidity		80%
Tolerable air-pressure	708 hPa (approx. Altitude 3000m)	

### 5.2. EMI-Standards

Designed to meet EMC (Electro-Magnetic Compatibility): Emission standard for industrial environments, according to EN 61000-6-4 and Immunity for industrial environments, according to EN 61000-6-2:

Description	Requirements	Test parameter	Criteria
Electromagnetic compatibility of multimedia equipment - Emission Requirements	EN 55032		Class A
Electrostatic discharge immunity test	EN 61000-4-2	±4 kV contact discharge, ±8 kV air discharge	Criteria B
Radiated, radio frequency, electromagnetic field immunity test	EN 61000-4-3	80-1000 MHz 10 V/m, 1,4-2 GHz 3 V/m 2-6 GHz 1 V/m 80 % AM (1 kHz)	Criteria A
Electrical fast transient/burst immunity test	EN 61000-4-4	±1 kV on I/O lines	Criteria B
Immunity to conducted disturbance, induced by radio-frequency fields	EN 61000-4-6	0,15 – 80 MHz 10 V <sub>rms</sub> 80 % AM (1 kHz)	Criteria A
Immunity to magnetic field	EN 61000-4-8	30 A/m	Criteria A

Note: To ensure that the board meets the standard mentioned above, an adequate shielding cover must be added. Alternatively, the housing of the monitor must act as shielding cover (e.g. aluminum enclosure).

### 5.3. Safety

- Designed to meet: IEC 62368-1
- Designed to meet UL 62368-1

**5.4. Shock and Vibration**

MECHANICAL STRESS

Shock:	20G, 11ms, half sine (x/y direction)
	15G, 11ms, half sine (z direction)
Vibration:	1.2G, 10 – 55Hz, sinus
Sweep:	1 minute/octave
Amplitude:	0.35mmp-p (x-direction)
	0.35mmp-p (y direction)
	0.175mmp-p (z-direction)
Time :	30 minutes
Standard:	Conform to EN60605

**5.5. Reliability, MTBF**

- min. 500.000h at Ta = 40°C, determined according to Telcordia SR-332

**6. Warranty, Quality and Environmentalism**

**6.1. Warranty**

- Manufacturer warranty: 12 month after delivery

**6.2. Quality**

The producing process of the board is aligned with the guideline according to the DIN ISO 9001 certification.

Workmanship standard: IPC-A-610D Class2

**6.3. Environmentalism**

The list of used materials is based on the parts list, which is available at DATA MODUL ERP-system

The PCB is produced under lead free soldering conditions.

All components are produced according to European RoHS (RoHS-1 = 2002/95/EU, RoHS-2 = 2011/65/EU) and REACH (2006/1907/EU) regulations. The board is designed and manufactured to meet ISO 14001.

The packing complies to directive 1994/62/EU.

## 7. Label and package

### 7.1. *Label and material number*

The following points are visible on the label of the eMotionNT2:3 board.

- Material number
- DATA MODUL Logo
- Serial- and Revision-number
- Manufacturing date
- UL-Sign on PCB

**DATA MODUL Aktiengesellschaft**

Landsberger Str. 322  
80687 Munich, Germany  
Tel. +49-89-5 60 17-0  
Fax +49-89-5 60 17-119  
[www.data-modul.com](http://www.data-modul.com)

**Logistics, Production & Services:**

DATA MODUL Weikersheim GmbH  
Lindenstrasse 8  
DE-97990 Weikersheim - Germany  
Phone: +49-7934-101-0  
Fax: +49-7934-101-101

**DATA MODUL's worldwide offices**

can be found on our website:  
[www.data-modul.com/eu/contact-worldwide.html](http://www.data-modul.com/eu/contact-worldwide.html)

