

# Specification

## **COM48H4P07ULC**

4,8" - 720 x 1280 – MIPI

Spec Revision: 4.0  
Revision Date: 15.02.2024

Note: This specification is subject to change without prior notice



**Specifications for**  
**Blanview TFT-LCD Monitor**  
**( 4.8" HD 720 x RGB x 1280 Portrait)**

Version 4.0

(Please be sure to check the specifications latest version. )

MODEL COM48H4P07ULC

Customer's Approval

Signature :

Name :

Section :

Title :

Date :

# ORTUSTECH



TOPPAN INC.  
Electronics Division  
Technological Development Department III

Approved by

*S. Epuclri*

Checked by





*J. Matsuzaki*

Prepared by

*M. Jojo*

## TOPPAN INC.

## Version History

Ver.	Date	Page	Description	
0.0	Aug.4,2021	-	-	Tentative issue
1.0  x8	Oct.6.2021	-		First issue
		P.13	Add	8.1 DC Characteristics Rating
		P.14	Correct	Error correct
		P.17	Correct	8.2 AC Characteristics Error correct
		P.22	Correct	10.1 Power-ON Sequence Error correct
			Correct	10.2 Power-OFF Sequence Error correct
		P.24	Correct	12.1 Optical Characteristics Error correct
		P.25	Correct	12.2 Temperature Characteristics Error correct
2.0  x2	Dec.17,2021	P.23	Correct	11. External Power on/off Sequence Error correct
		P.26	Correct	13.1 Defective Display and Screen Quality Error correct
3.0  x7	Jan.14,2022	P.11	Change	5. Pin Assignment VCC rating
		P.12	Change	7. Recommended Operating Conditions VCC rating
		P.13	Change	8.1 DC Characteristics VCC rating
		P.15,16	Change	8.2 AC Characteristics VCC rating
		P.24	Change	12.1 Optical Characteristics VCC rating
		P.25	Change	12.2 Temperature Characteristics VCC rating
			Change	VCC rating
4.0  x3	Feb.15,2024	All	Change	All Company name font
		P.1	Change	Cover Department name
		P.18	Change	7.2.4 Reset input timing
			Correct	Error correct

## Contents

1. Application	.....	4
2. Outline Specifications		
2.1 Features of the Product	.....	5
2.2 Display Method	.....	5
3. Dimensions and Shape		
3.1 Dimensions	.....	7
3.2 Outward Form	.....	8
3.3 Serial № print (S-print)	.....	9
4. Block Diagram	.....	10
5. Pin Assignment	.....	11
6. Absolute Maximum Rating	.....	12
7. Recommended Operating Conditions	.....	12
8. Electrical Characteristics		
8.1 DC Characteristics	.....	13
8.2 AC Characteristics	.....	15
8.3 Input Timing Characteristics	.....	18
8.4 Input Signal Timing Char	.....	19
9. About MIPI Interface		
9.1 Version	.....	20
9.2 DSI protocol	.....	20
9.3 Packet data types	.....	21
9.4 Packet Footer on the long packet	.....	21
10. Sequence		
10.1 Power-ON Sequence	.....	22
10.2 Power-OFF Sequence	.....	22
10.3 Sleep Sequence	.....	22
10.4 Sleep Release Sequence	.....	22
11. External Power on/off Sequence	.....	23
12. Characteristics		
12.1 Optical Characteristics	.....	24
12.2 Temperature Characteristics	.....	25
13. Criteria of Judgment		
13.1 Defective Display and Screen Quality	.....	26
13.2 Screen and Other Appearance	.....	27
14. Reliability Test		
15. Packing Specifications	.....	30
16. Handling Instruction		
16.1 Cautions for Handling LCD panels	.....	31
16.2 Precautions for Handling	.....	32
16.3 Precautions for Operation	.....	32
16.4 Storage Condition for Shipping Cartons	.....	33
16.5 Precautions for Peeling off the Protective film	.....	34
16.6 Warranty	.....	34
APPENDIX	.....	35

## 1. Application

This Specification is applicable to 120.7mm (4.8 inch) Blanview TFT-LCD monitor for non-military use.

- ◎ TOPPAN makes no warranty or assume no liability that use of this Product and/or any information including drawings in this Specification by Purchaser is not infringing any patent or other intellectual property rights owned by third parties, and TOPPAN shall not grant to Purchaser any right to use any patent or other intellectual property rights owned by third parties. Since this Specification contains TOPPAN's confidential information and copy right, Purchaser shall use them with high degree of care to prevent any unauthorized use, disclosure, duplication, publication or dissemination of TOPPAN's confidential information and copy right.
- ◎ If Purchaser intends to use this Products for an application which requires higher level of reliability and/or safety in functionality and/or accuracy such as transport equipment (aircraft, train, automobile, etc.), disaster-prevention/security equipment or various safety equipment, Purchaser shall consult TOPPAN on such use in advance.
- ◎ This Product shall not be used for application which requires extremely higher level of reliability and/or safety such as aerospace equipment, telecommunication equipment for trunk lines, control equipment for nuclear facilities or life-support medical equipment.
- ◎ It must be noted as an mechanical design manner, especial attention in housing design to prevent arcuation/flexure caused by stress to the LCD module shall be considered.
- ◎ TOPPAN assumes no liability for any damage resulting from misuse, abuse, and/or miss-operation of the Product deviating from the operating conditions and precautions described in the Specification.
- ◎ It shall be mutually conferred if nonconforming defect which result from unspecified cause in this specification arises.
- ◎ If any issue arises as to information provided in this Specification or any other information, TOPPAN and Purchaser shall discuss them in good faith and seek solution.
- ◎ TOPPAN assumes no liability for defects such as electrostatic discharge failure occurred during peeling off the protective film or Purchaser's assembly process.
- ◎ This Product is compatible for RoHS(2.0) directive.

Object substance	Maximum content [ppm]
Cadmium and its compound	100
Hexavalent Chromium Compound	1000
Lead & Lead compound	1000
Mercury & Mercury compound	1000
Polybrominated biphenyl series (PBB series)	1000
Polybrominated biphenyl ether series (PBDE series)	1000
Bis(2-ethylhexyl)phthalate series(DEHP series)	1000
Butyl benzyl phthalate series(BBP series)	1000
Dibutyl phthalate series(DBP series)	1000
Diisobutyl phthalate series(DIBP series)	1000

## 2. Outline Specifications

### 2.1 Features of the Product

- 4.8 inch diagonal display, 720 x RGB [H] x 1280 [V] dots.
- 24bitRGB ( 8-8-8 Format ) / 16.7 Million colors.
- MIPI DSI as high-speed interface. Video mode only.
- Timing generator [TG], Counter-electrode driving circuitry, Built-in power supply circuit.
- Various display controls and functional selection.
- Blanview TFT-LCD, improved outdoor readability.

\* MIPI : Mobile Industrial Processor Interface , DSI : Display Serial Interface

	Indoor		Outdoor	
	Readability	Power Efficiency (Battery Life)	Readability	Power Efficiency (Battery Life)
Transmissive	Good	Good	Fair	Poor
Transflective	Fair	Poor	Good	Good
Blanview	Good	Good	Good	Good

### 2.2 Display Method

Items	Specifications	Remarks
Display type	VA 16.7 Million colors. Blanview, Normally black.	
Driving method	a-Si TFT Active matrix. Line-scanning, Non-interlace.	
Dot arrangement	RGB stripe arrangement.	Refer to "Dot arrangement"
Signal input method	MIPI DSI 4-lanes : 4 data lanes and 1 clock lane	in foot note 1
Backlight type	Long life & High bright white LED.	
NTSC Ratio	50%	

Foot note1: when use MIPI DSI 2-lanes, Please contact Toppan.

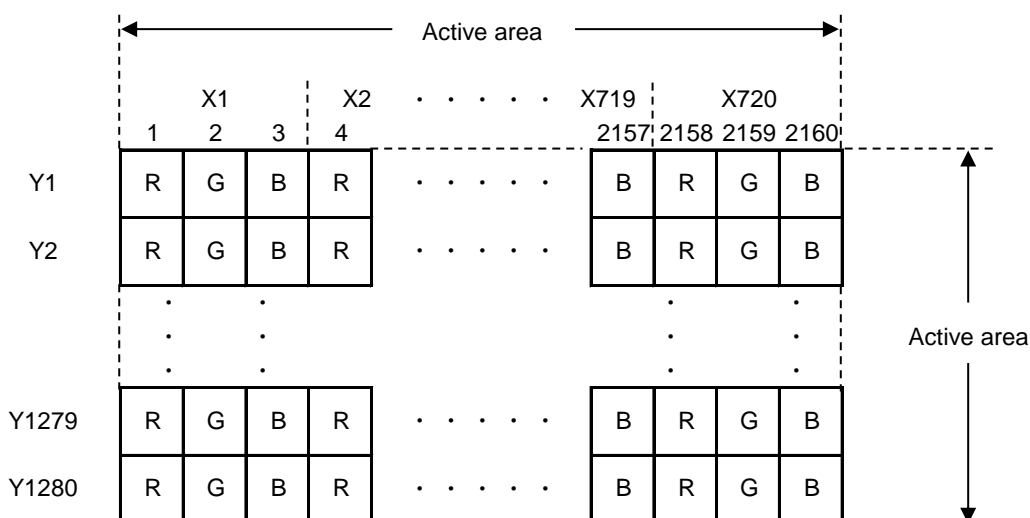

Dot arrangement (FPC cable placed low)

<Features of Blanview>

- Backlight power consumption required to assure visibility. (equivalent to 3.5"QVGA )

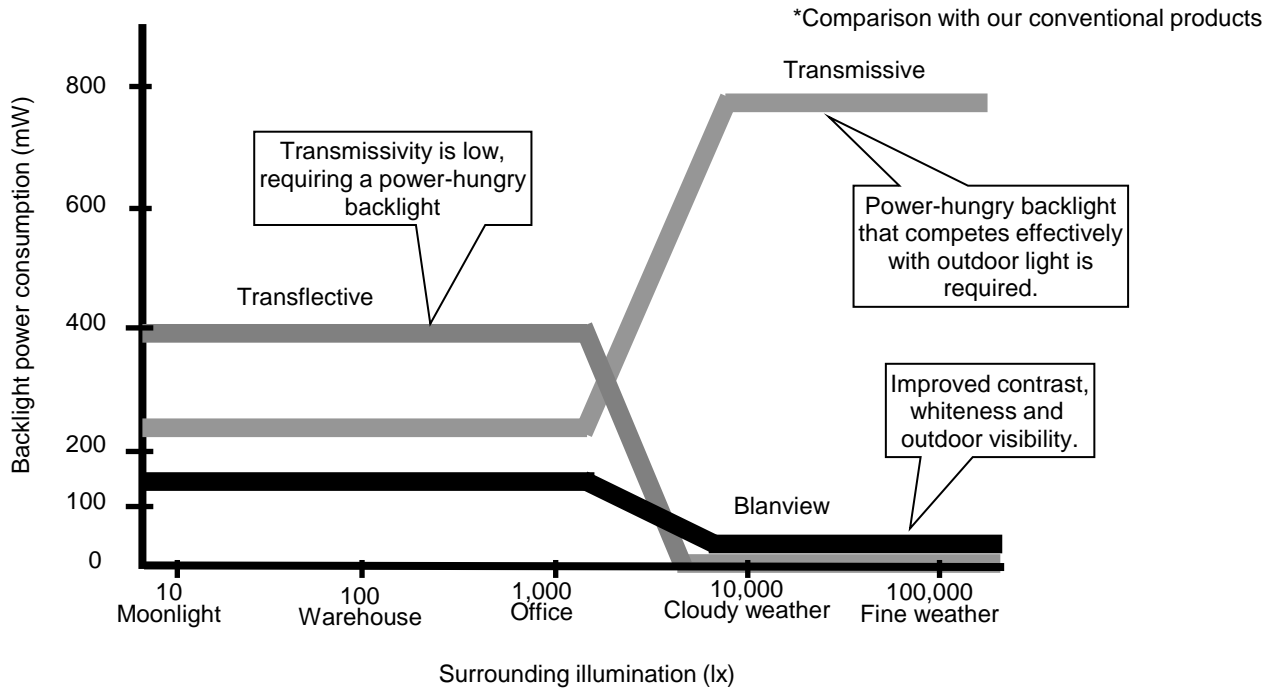

- Contrast characteristics under 100,000lx. (same condition as direct sunlight.)

With better contrast (higher contrast ratio), Blanview TFT-LCD has the best outdoor readability in three different types of TFT-LCD.

Below chart shows contrast value against panel surface brightness. (Horizontal: Panel surface brightness/ Vertical: Contrast value) LCD panel has enough outdoor readability above our Standard line. (TOPPAN criteria)

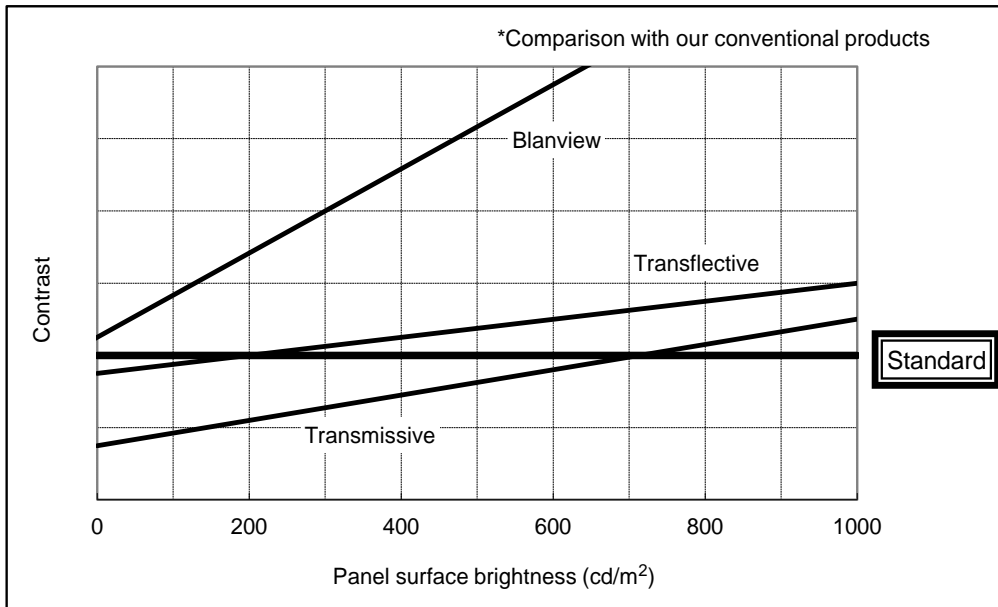

## 3. Dimensions and Shape

## 3.1 Dimensions

Items	Specifications	Unit	Remarks
Outline dimensions	64.58 [H] × 115.41 [V] ×2.05 [D]	mm	Exclude FPC cable
Active area	59.184[H] × 105.216[V]	mm	120.7 mm diagonal
Number of dots	2160[H] × 1280[V]	dot	
Dot pitch	27.4[H] × 82.2[V]	um	
Surface hardness of the polarizer	2	H	Load: 2.94N
Weight	29.97	g	



3.2 Outward Form

(8/37)  
21TLM036  
Issue: Feb.15,2024

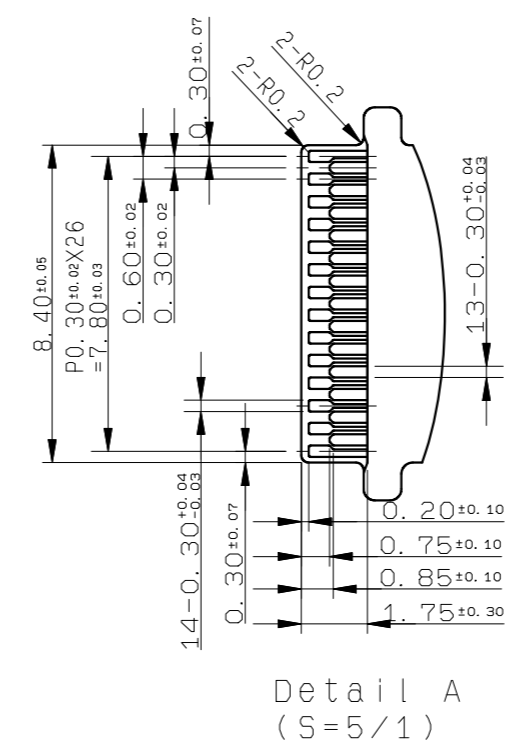
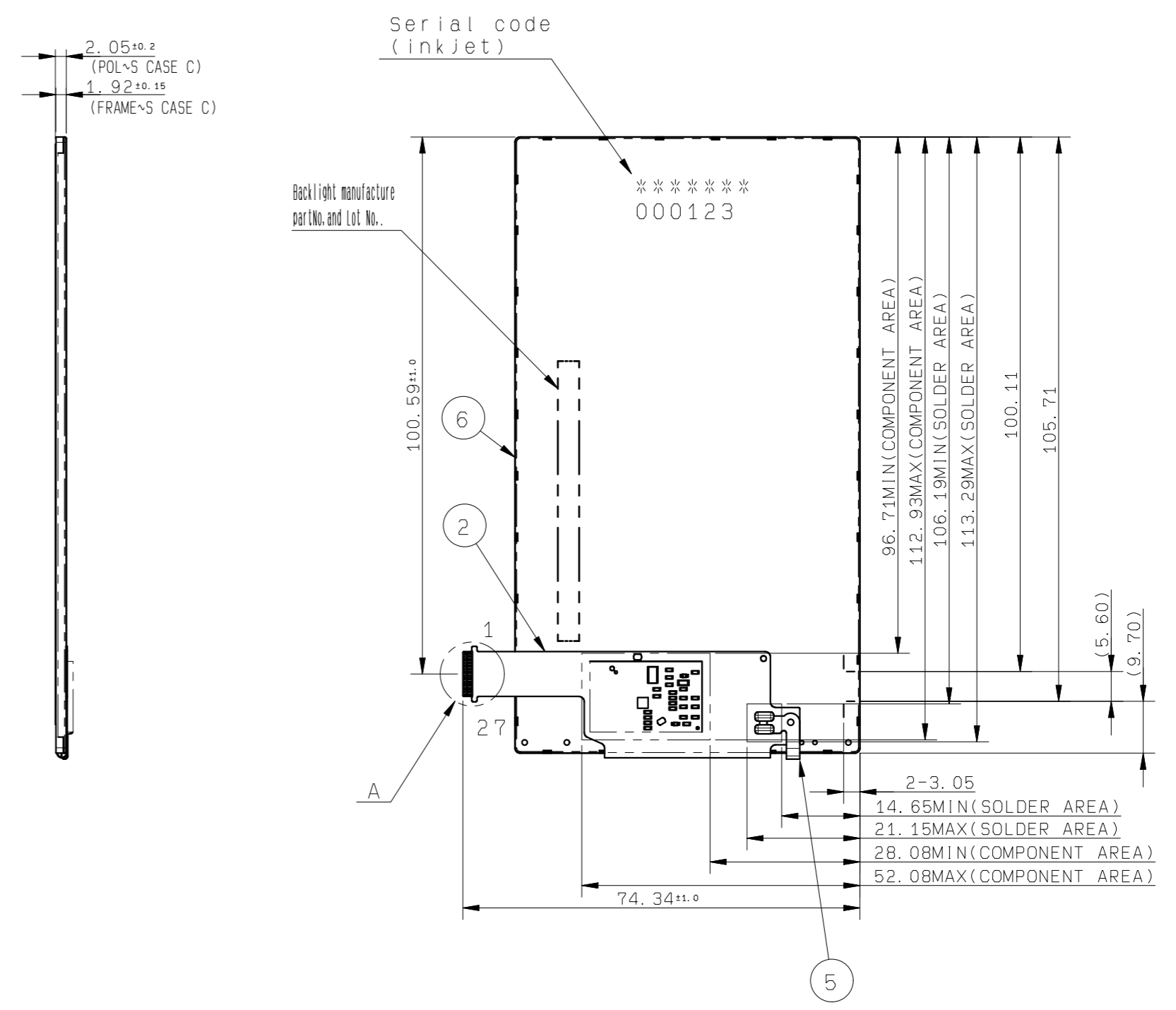
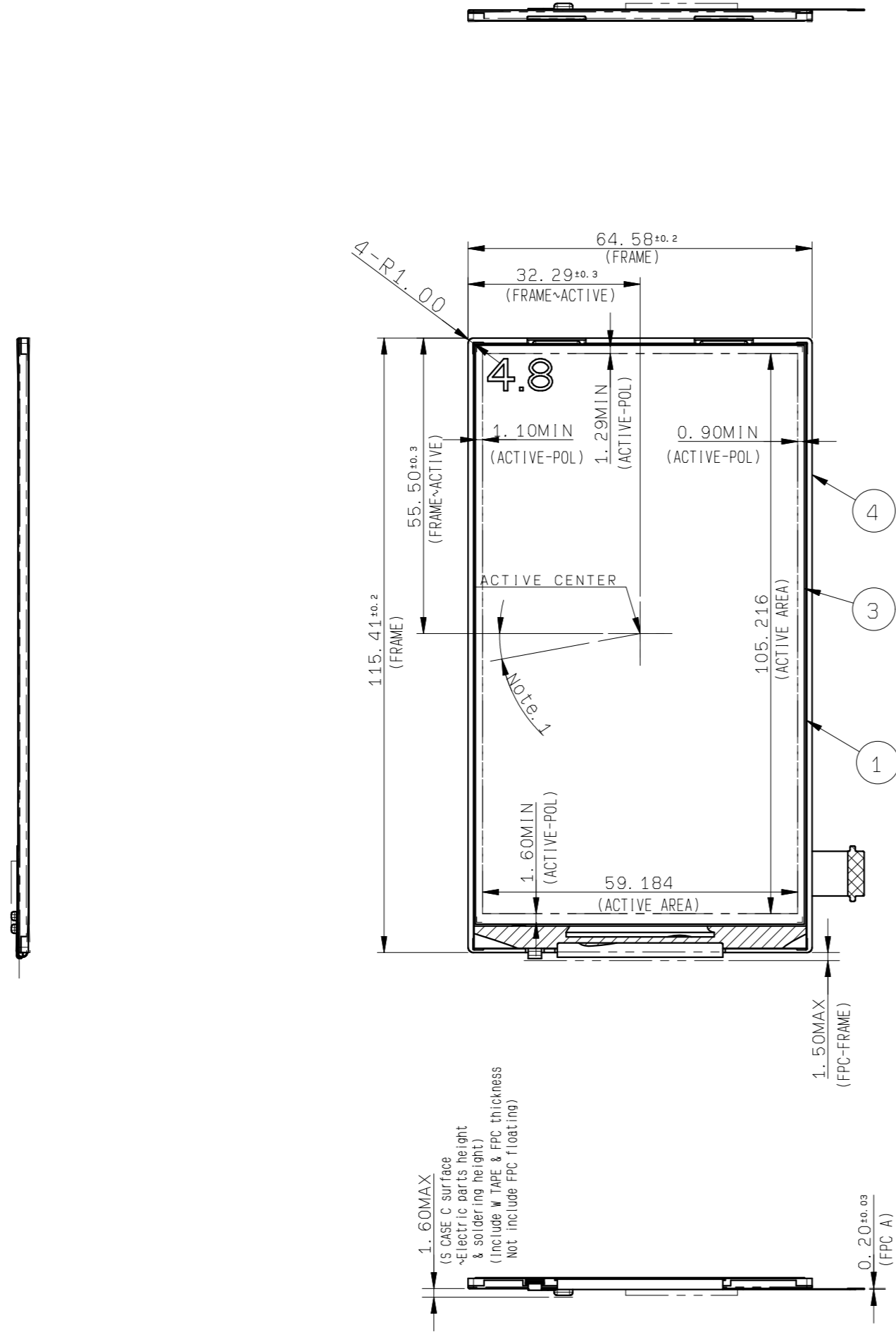

- Note 1. Angular deviation of LCD cell from the TFT-LCD monitor's reference axis shall be less than [±40'].
- Note 2. Protective film is affixed on front surface of the screen. Location tolerance of the protective film shall be ±1.5 mm to the polarizing film.
- Note 3. Recommended FPC connector. For FPC A : HIROSE, part number: FH35C-27S-0.35HW

S CASE C	6		SUS(t=0.15)	
FPC B	5			Use of LED
FRAME	4		PC	
POLARIZER	3			With protection sheet
FPC A	2			Use of LCD
TFT-LCD	1		Glass thickness=0.25±0.25t	
PART NAME	ITEM	PART CODE	MODEL NUMBER	REMARK
APPROVED 尾木	GENERAL TOLERANCE ±0.5	SCALE 1/1	UNIT mm	<b>TOPPAN</b> TOPPAN INC. DO NOT DUPLICATE, CONFIDENTIAL AND PROPRIETARY DRAWING No. REV. SHEET DIV.
CHECKED 加藤	ISSUE (Y-M-D) 20:11:27	MODEL COM48H4P07U**		
CHECKED	NAME			
DESIGN 前田創	OUTLINE-D4P07			
DRAW 前田創			RJD601117D201	ASS'Y

### 3.3 Serial № print (S-print)

#### 3.3.1 Display Items

S-print indicates the least significant digit of manufacture year (1digit), manufacture month with below alphabet (1letter), model code (5characters), serial number (6digits).

#### \* Contents of Display

*	*	*****	*****
-	-	-	-
a	b	c	d

Contents of display				
a	The least significant digit of manufacture year			
b	Manufacture month	Jan-A Feb-B Mar-C Apr-D	May-E Jun-F Jul-G Aug-H	Sep-I Oct-J Nov-K Dec-L
c	Model code	48BPC (Made in Japan) 48BQC (Made in Malaysia)		
d	Serial number			

#### \* Example of indication of Serial № print (S-print)

- Made in Japan

1L48BPC000125

means "manufactured in December 2021, 4.8" BP type, C specifications, serial number 000125"

- Made in Malaysia

1L48BQC000125

means "manufactured in December 2021, 4.8" BQ type, C specifications, serial number 000125"

#### 3.3.2 Location of Serial № print (S-print)

Refer to 3.2 "Outward Form".

#### 3.3.3 Others

Please note that it is likely to disappear with an organic solvent about the Serial print.

4. Block Diagram

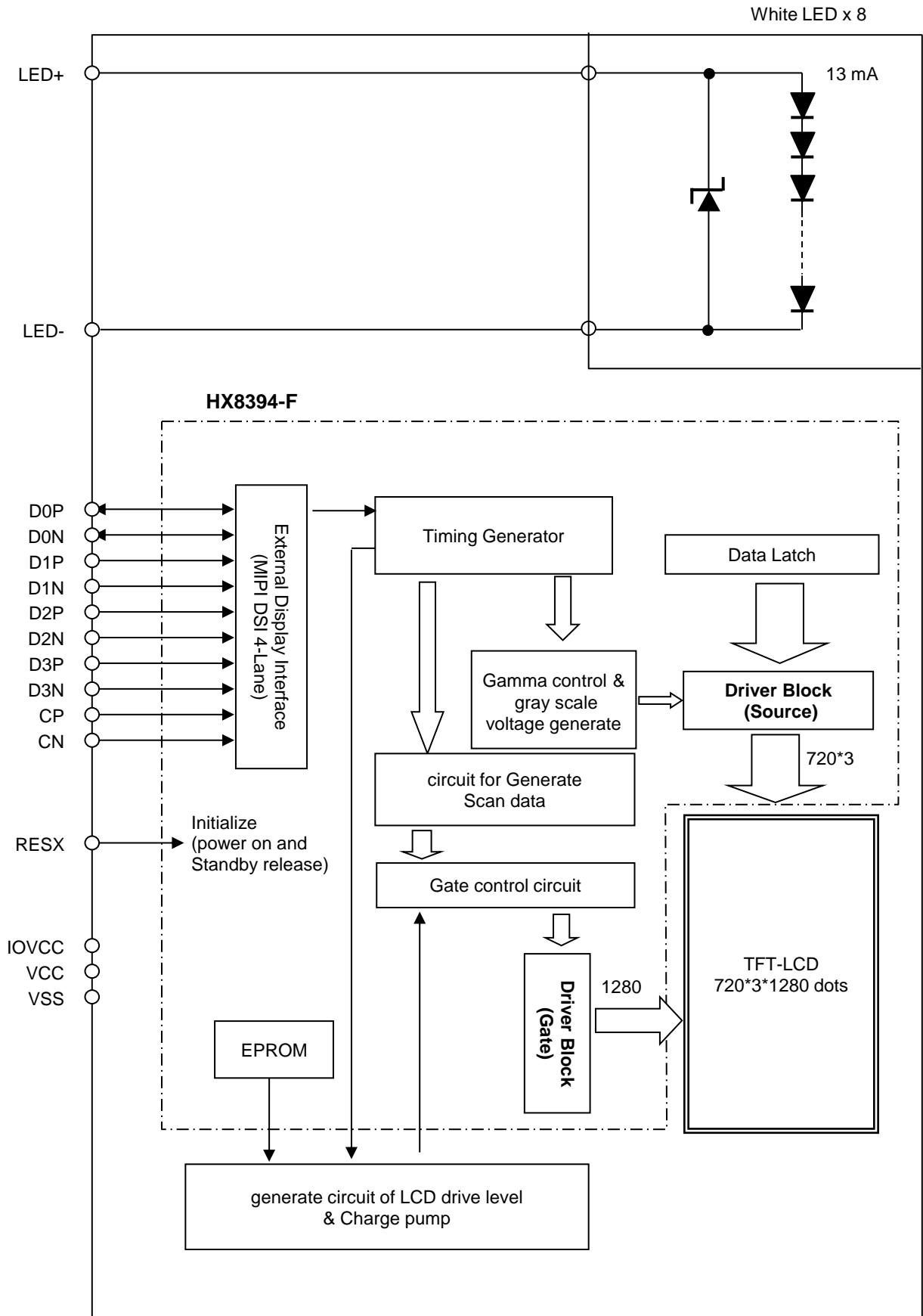

## 5. Pin Assignment

No.	Symbol	Details	Remark	IO
1	VSS	Ground		P
2	NC	Non connection		-
3	LED+	Backlight LED Anode		P
4	NC	Non connection		-
5	LED-	Backlight LED Cathode		P
6	VCC	Analog Power Supply	VCC = 2.9V (TYP)	P
7	VSS	Ground		P
8	IOVCC	DSI and I/O Power Supply	IOVCC = 1.8V (TYP)	P
8	RESX	LCD Reset	L:Initialize , Power_ON Reset is Required when Turning on the Power	I
10	VSS	Ground		P
11	TEST OUT	TEST Signal output	Test Pin. Please Open this pin	O
12	VSS	Ground		P
13	D3P	MIPI-DSI Data differential signal pin (Data lane 3)		I
14	D3N	MIPI-DSI Data differential signal pin (Data lane 3)		I
15	VSS	Ground		P
16	D2P	MIPI-DSI Data differential signal pin (Data lane 2)		I
17	D2N	MIPI-DSI Data differential signal pin (Data lane 2)		I
18	VSS	Ground		P
19	CP	MIPI-DSI Clock differential signal pin		I
20	CN	MIPI-DSI Clock differential signal pin		I
21	VSS	Ground		P
22	D1P	MIPI-DSI Data differential signal pin (Data lane 1)		I
23	D1N	MIPI-DSI Data differential signal pin (Data lane 1)		I
24	VSS	Ground		P
25	D0P	MIPI-DSI Data differential signal pin (Data lane 0)		IO
26	D0N	MIPI-DSI Data differential signal pin (Data lane 0)		IO
27	VSS	Ground		P

- Recommended connector : ( FH35C-27S-0.3SHW(50) /HIROSE ELECTRIC)
- Please make sure to check a consistency between pin assignment in "3.2 Outward Form" and your connector pin assignment when designing your circuit.  
Inconsistency in input signal assignment may cause a malfunction.
- Since FPC cable has gold plated terminals, gilt finish contact shoe connector is recommended.

## 6. Absolute Maximum Rating

VSS=0V

Item	Symbol	Condition	Rating		Unit	Applicable terminal
			MIN	MAX		
Supply voltage	VCC	Ta=25 °C	-0.3	3.6	V	VCC
DSI and I/O Power Supply voltage	IOVCC		-0.3	3.6	V	IOVCC
Input voltage for logic	VI		-0.3	IOVCC+0.3	V	RESX
DSI Input voltage	VDSIIN		-0.3	2.0	V	D0P/N D2P/N D1P/N D3P/N CP/N
LED forward current	IL	Ta = 25 °C	-	35	mA	LED+ - LED-
		Ta = 70 °C	-	15		
Storage temperature range	Tstg		-30	80	°C	
Storage humidity range	Hstg	Non condensing in an environmental moisture at or less than 40 °C 90%RH.				

## 7. Recommended Operating Conditions

VSS=0V

Item	Symbol	Condition	Rating			Unit	Applicable terminal
			MIN	TYP	MAX		
Supply voltage	VCC		2.7	2.9	3.0	V	VCC
DSI and I/O Power Supply voltage	IOVCC		1.7	1.8	2.0	V	IOVCC
Input voltage for logic	VI		0	-	IOVCC	V	RESX
DSI Input voltage	VDSIIN		-0.15	-	1.45	V	D0P/N D2P/N D1P/N D3P/N CP/N
Operational temperature range	Top	Note1,2	-20	25	70	°C	Panel surface temperature
Operating humidity range	Hop	Ta<=40 °C	20	-	85	%	
		Ta>40 °C	Non condensing in an environmental moisture at or less than 40 °C 85%RH.				

Note1: This monitor is operatable in this temperature range. With regard to optical characteristics, refer to Item 12."CHARACTERISTICS".

Note 2: Acceptable Forward Current to LED is up to 15 mA, when Ta=+70 °C.  
Do not exceed Allowable Forward Current shown on the chart below.

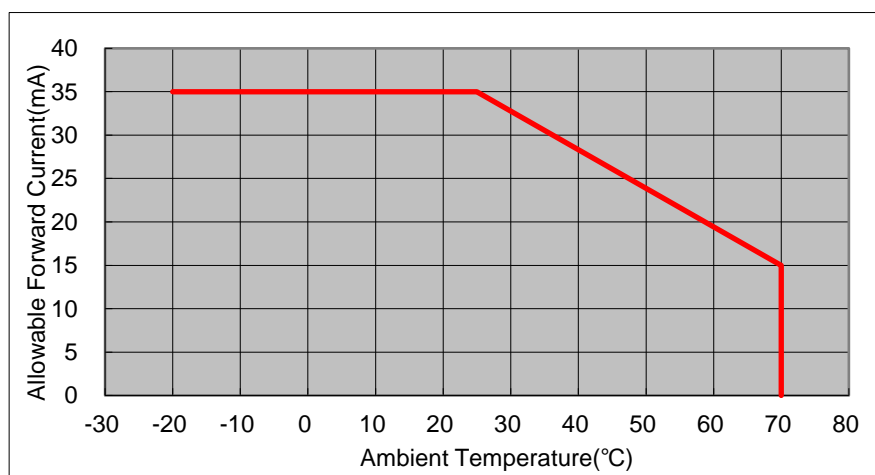

## 8. Electrical Characteristics

## 8.1 DC Characteristics

## 8.1.1 Display Module

(Unless otherwise noted, Ta=25 °C, VCC=2.9V, IOVCC=1.8V, VSS=0V)

Item	Symbol	Condition	Rating			Unit	Applicable terminal
			MIN	TYP	MAX		
Input Signal Voltage	VIH	IOVCC=1.7-2.0V	0.7×IOVCC	-	IOVCC	V	RESX
	VIL		0	-	0.3×IOVCC	V	
Operating Current	ICC	Still Image*	-	29.5	59	mA	VCC
	ICCIO		-	17.5	35	mA	IOVCC
Sleep_mode Current	ICCS	Clock/Data=LP11	-	50	100	µA	VCC
	ICCIOS	Sleep_mode	-	75	200	µA	IOVCC

\* A still image (color bar) on display , when accessing to the driver by MIPI DSI 4Lane.

The details of the drive condition of MIPI DSI are referring to the following.

Vsync pulse width	3 line	Hsync pulse width	15 clk	Frame Rate	58.1 Hz
V-Back porch	3 line	H-Back porch	70 clk	Data Rate	403.2 Mbps
V-Front porch	6 line	H-Front porch	91 clk	CLK frequency	201.6 MHz
V-Line	1280 line	H-Line	720 clk		

## 8.1.2 MIPI DSI Interface

Item	Symbol	Condition	Rating			Unit	Note
			MIN	TYP	MAX		
HS-RX	Differential input high threshold	VIDTH	-	-	70	mV	
	Differential input low threshold	VIDTL	-70	-	-	mV	
	Single-ended input high voltage	VIHHS	-	-	460	mV	
	Single-ended input low voltage	VILHS	-40	-	-	mV	
	Common-mode voltage HS receive mode	VCMRXD C	70	-	330	mV	
	Differential input impedance	ZID	80	100	125	Ohm	
LP-RX	Logic 1 input voltage	VIH	880	-	-	mV	
	Logic 0 input voltage	VIL	-	-	550	mV	
LP-TX	Thevenin output low level	VOL	-50	-	50	mV	
	Thevenin output high level	VOH	1.1	1.2	1.3	V	
	Output impedance of LP transmitter	ZOLP	110	-	-	Ohm	
CD-RX	Logic 1 contention threshold	VIHCD	450	-	-	mV	
	Logic 0 contention threshold	VILCD	-	-	200	mV	

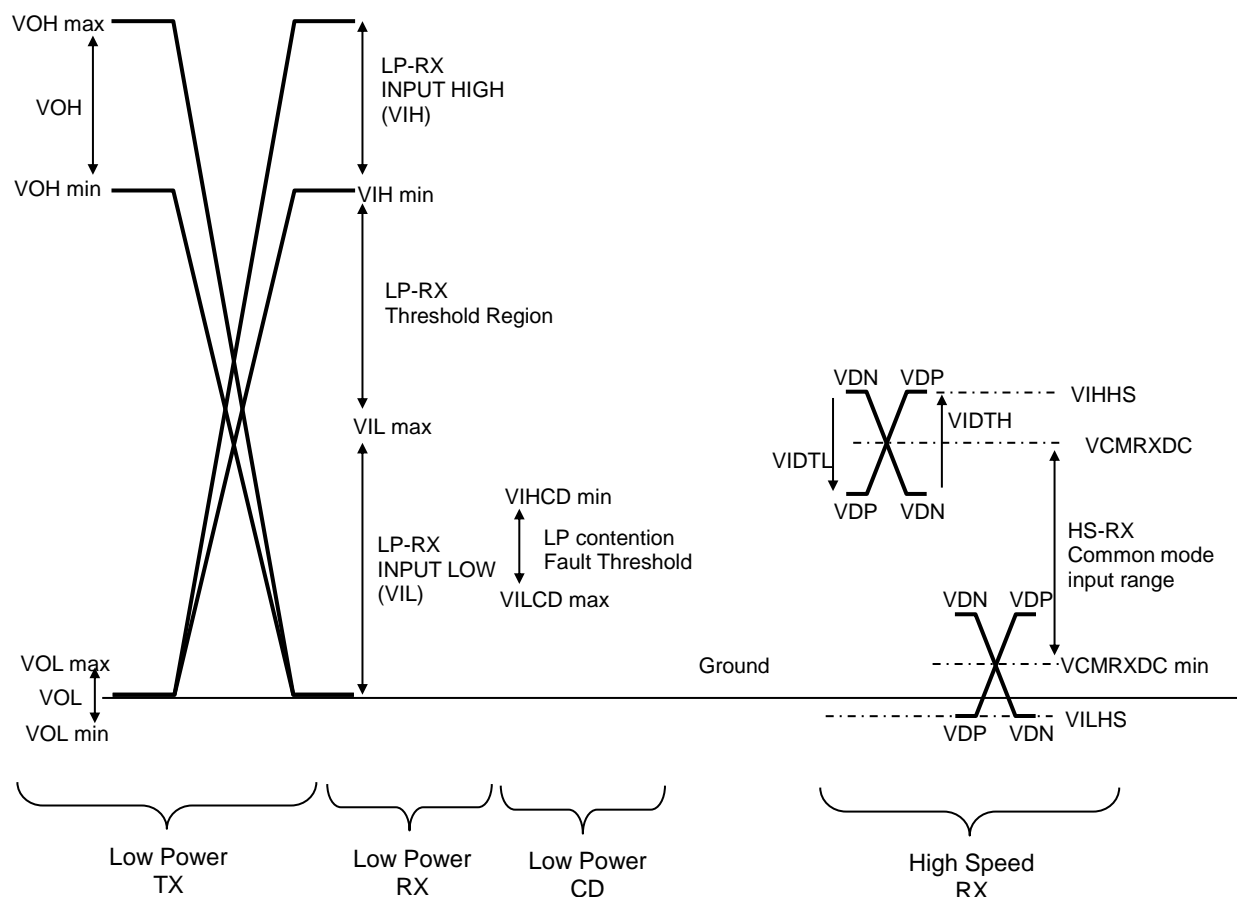

The signal levels for the LP and HS .

### 8.1.3 Backlight

Item	Symbol	Condition	Rating			Unit	Applicable terminal
			MIN	TYP	MAX		
Forward current	IL25	Ta=25 °C	--	13	35	mA	LED+ - LED-
	IL70	Ta=70 °C	--	--	15	mA	
Forward voltage (*Reference only)	VL	Ta=25 °C IL=13mA	20.6*	22.2*	23.5*	V	
Estimated Life of LED	LL	Ta=25 °C IL=13mA Note	--	50000	--	hrs	

- Note:
- The lifetime of the LED is defined as a period till the brightness of the LED decreases to the half of its initial value.
  - This figure is given as a reference purpose only, and not as a guarantee.
  - This figure is estimated for an LED operating alone.  
As the performance of an LED may differ when assembled as a monitor together with a TFT panel due to different environmental temperature.
  - Estimated lifetime could vary on a different temperature and usually higher temperature could reduce the life significantly.

## 8.2 AC Characteristics

## 8.2.1 HS-RX Specifications

(Unless otherwise noted,  $T_a=25\text{ }^\circ\text{C}$ ,  $V_{CC}=2.9\text{V}$ ,  $IOV_{CC}=1.8\text{V}$ ,  $V_{SS}=0\text{V}$ )

Item	Symbol	Condition	Rating			Unit	Applicable terminal
			MIN	TYP	MAX		
DSICLK Frequency	f DSICLK		40	-	250	MHz	CP/N
DSICLK Cycle time	TCLKP		4.0	-	25.0	ns	
DSI Data Transfer Rate	UI		2.0	-	12.5	ns	D0P/N,D1P/N
	t DSIR		80	-	500	Mbps	D2P/N,D3P/N
Data to Clock Setup Time	Tsetup		0.15	-	-	UI	D0P/N,D1P/N
Clock to Data Hold Time	Thold		0.15	-	-	UI	D2P/N,D3P/N CP/N

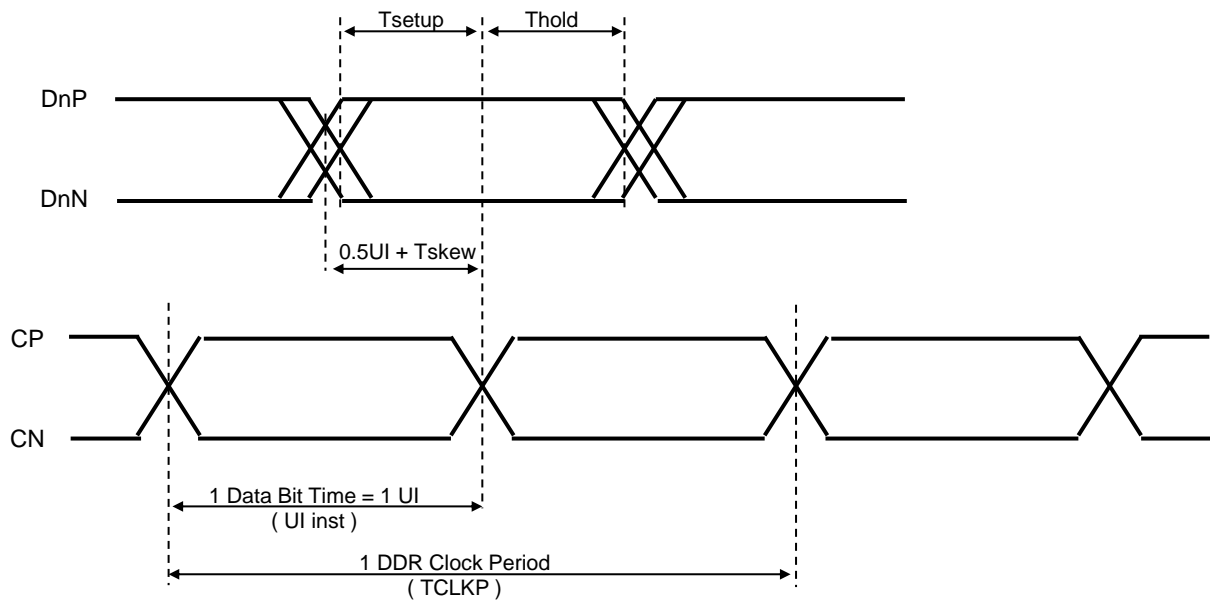

Data to Clock Timing Definitions

## 8.2.2 LP-TX Specifications

(Unless otherwise noted,  $T_a=25\text{ }^\circ\text{C}$ ,  $V_{CC}=2.9\text{V}$ ,  $IOV_{CC}=1.8\text{V}$ ,  $V_{SS}=0\text{V}$ )

Item	Symbol	Condition	Rating			Unit	Applicable terminal
			MIN	TYP	MAX		
15% - 85% rise time	TRLP		-	-	25	ns	D0P/N
85% - 15% fall time	TFLP		-	-	25	ns	
Slew rate	$\Delta V / \Delta t_{SR}$	Clload = 70pF	-	-	150	mV/ns	



## 8.2.3 RX/TX Specifications

(Unless otherwise noted, Ta=25 °C, VCC=2.9V, IOVCC=1.8V, VSS=0V)

Item	Description	Rating			Unit
		MIN	TYP	MAX	
$T_{HS-PREPARE}$	Time to drive LP00 to prepare for HS transmission	40 ns + 4UI	-	85 ns + 6UI	
$T_{HS-PREPARE} + T_{HS-ZERO}$	$T_{HS-PREPARE}$ + Time to drive HS0 before the SYNC sequence	145 ns + 10UI	-	-	
$T_{HS-TRAIL}$	Time to drive flipped differential state after last payload data bit of a HS transmission burst	$\max(n*8UI, 60\text{ ns} + n*4UI)$	-	-	
$T_{HS-EXIT}$	Time to drive LP11 after HS burst	100	-	-	ns
$T_{TA-GO}$	Time to drive LP00 after Turnaround Request	$4*T_{LPTX}$			
$T_{TA-SURE}$	Time out before new TX side starts driving	$T_{LPTX}$	-	$2*T_{LPTX}$	
$T_{TA-GET}$	Time to drive LP00 by new TX	$5*T_{LPTX}$			
$T_{LPX}$	Length of any Low Power state period	50	-	-	ns
Ratio $T_{LPX}$	Ratio of $T_{LPX}(\text{MASTER})/T_{LPX}(\text{SLAVE})$ between Master and Slave side	2/3	-	3/2	
$T_{CLK-POST}$	Time that the transmitter shall continue sending HS clock after the last associated Data Lane has transitioned to LP mode	60 ns + 52UI	-	-	
$T_{CLK-PREPARE} + T_{CLK-ZERO}$	$T_{CLK-PREPARE}$ + time for lead HS-0 drive period before starting Clock	300	-	-	ns
$T_{CLK-PRE}$	Time that the HS clock shall be driven prior to any associated Data Lane beginning the transition from LP to HS mode	8	-	-	UI
$T_{CLK-PREPARE}$	Time to drive LP-00 to prepare for HS clock transmission	38	-	95	ns
$T_{CLK-TRAIL}$	Time to drive HS differential state after last payload clock bit of a HS transmission burst	60	-	-	ns
$T_{EOT}$	Time from start of $T_{HS-TRAIL}$ period to start of LP-11 state	-	-	105 ns + $n*12UI$	
$T_{LPTX1}$	Length of Low-Power TX state period in case of using DSI clock	-	$n*DSITX$	-	UI
$T_{LPTX2}$	Length of Low-Power TX state period in case of using internal OSC clock	-	1/fosc	-	ns

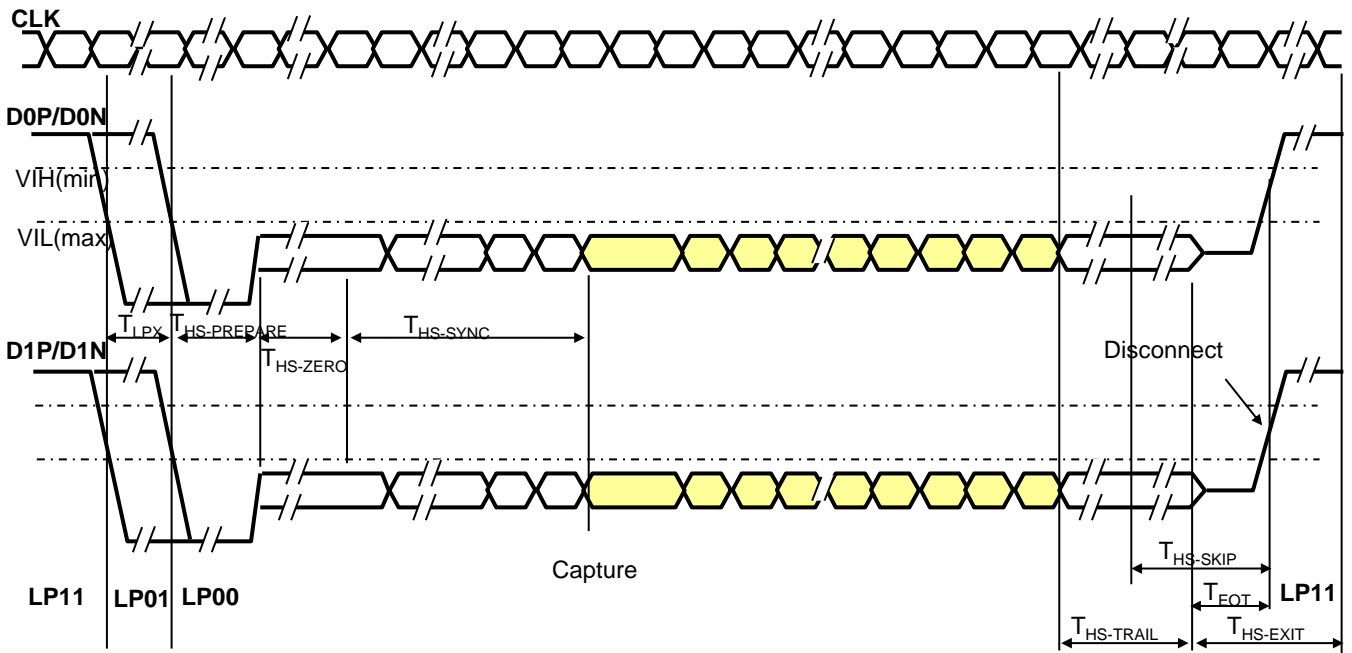

HS Data Transmission in Bursts

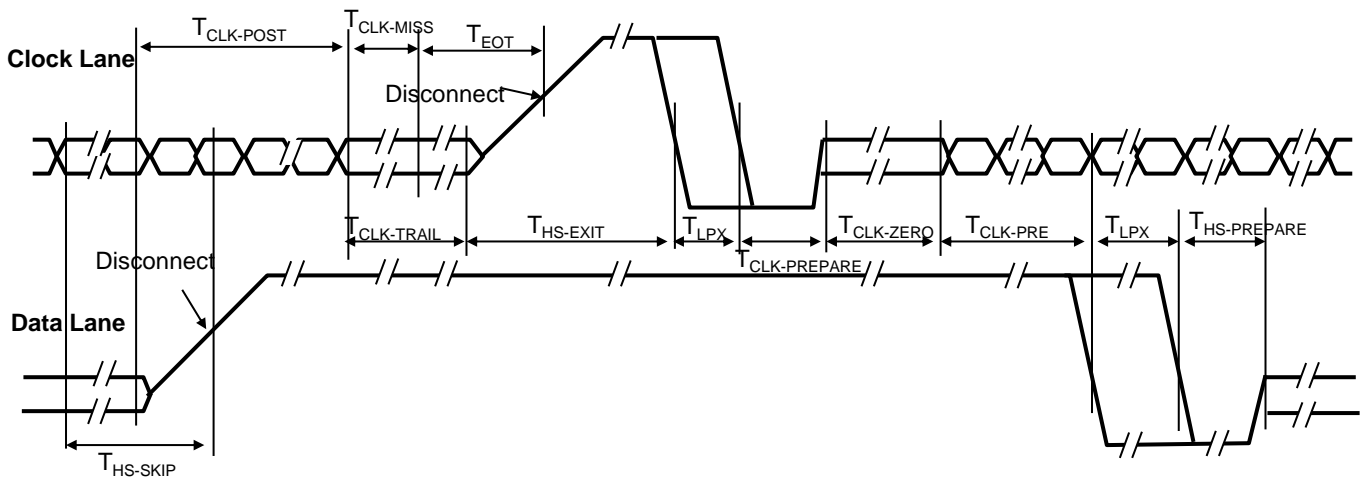

Switching the Clock Lane between Clock Transmission and LP mode

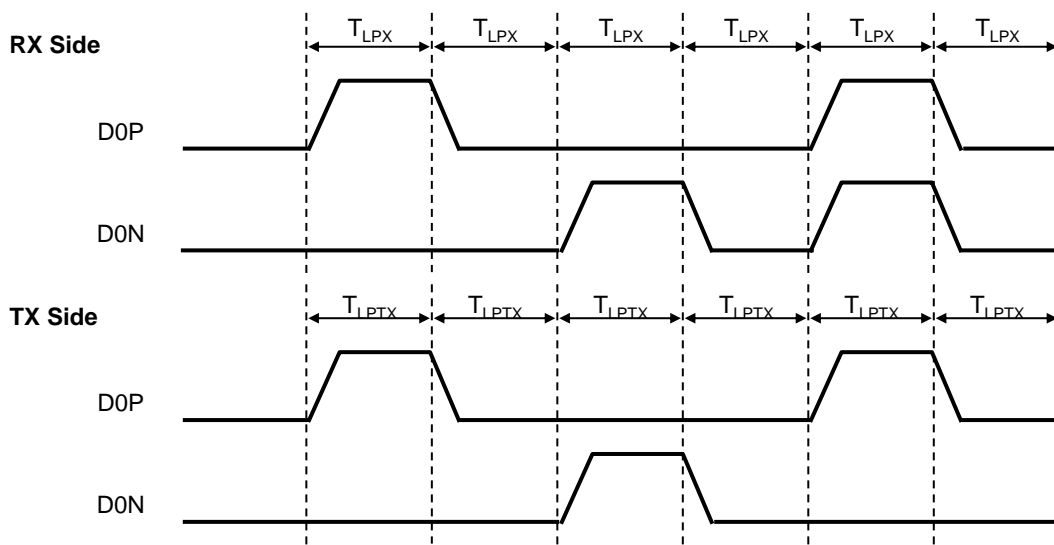

DSI LP Mode

### 8.2.4 Reset input timing

Item	Symbol	Condition	Rating			Unit	Remark
			MIN	TYP	MAX		
Reset Low Pulse width	tRESW		10	-	-	us	RESX

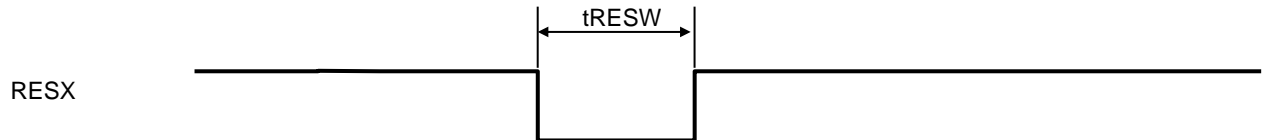

### 8.3 Input Timing Characteristics

Item	Symbol	Condition	Rating			Unit	Remark
			MIN	TYP	MAX		
CLK Frequency	fPCLK		62.5	67.3	-	MHz	PCLK
VSYNC Frequency	Note fVSYNC		54	58.1	66	Hz	VSYNC
VSYNC Cycle	tv		1292	1292	-	H	
VSYNC Pulse Width	VS		3	3	-	H	
Vertical Back Porch	tvb		3	3	-	H	
Vertical Front Porch	tvf		6	6	-	H	
Vertical data start Point	VS+tvb		6	6	-	H	
Vertical Blanking Period	VS+tvb+tvf		12	12	-	H	
Vertical Display Period	tvdp		-	1280	-	H	
HSYNC frequency	fHSYNC		69.8	75.1	-	kHz	
HSYNC Cycle	th		-	896	-	CLK	
HSYNC Pulse Width	HS		-	15	-	CLK	
Horizontal Back Porch	thb		-	70	-	CLK	
Horizontal Front Porch	thf		-	91	-	CLK	
Horizontal data start Point	HS+thb		-	85	-	CLK	
Horizontal Blanking Period	HS+thb+thf		-	176	-	CLK	
Horizontal Display Period	thdp		-	720	-	CLK	

Note: This is recommended spec to get high quality picture on display. It is customer's risk to use out of this frequency.

### 8.4 Input Signal Timing Chart

#### ·Vertical Timing

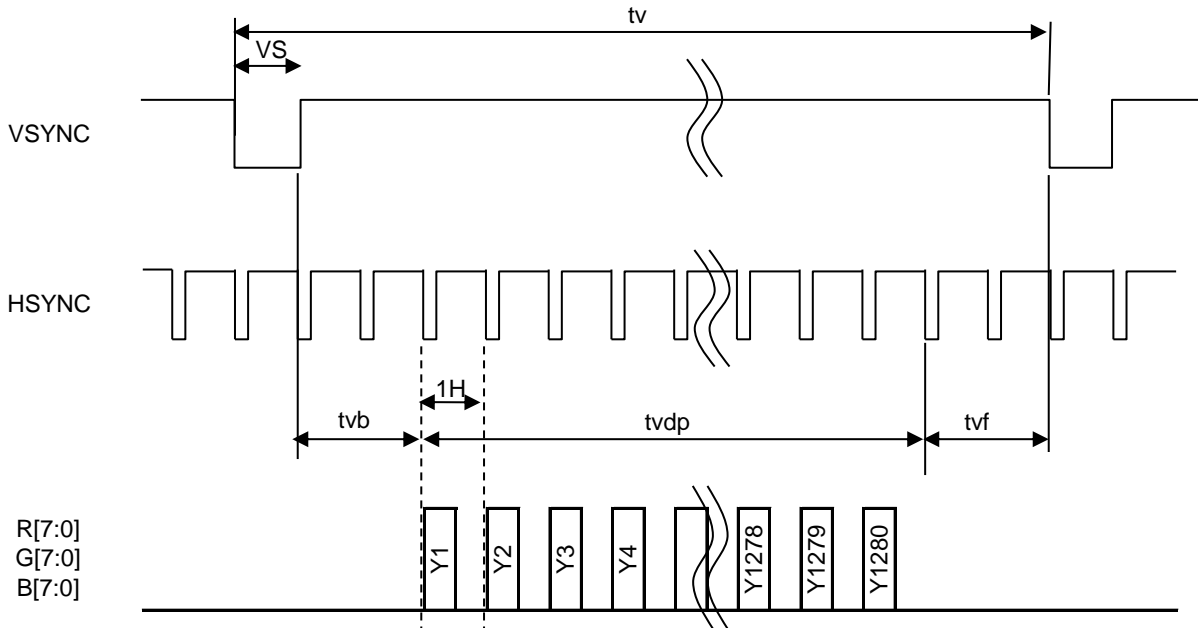

#### ·Horizontal Timing

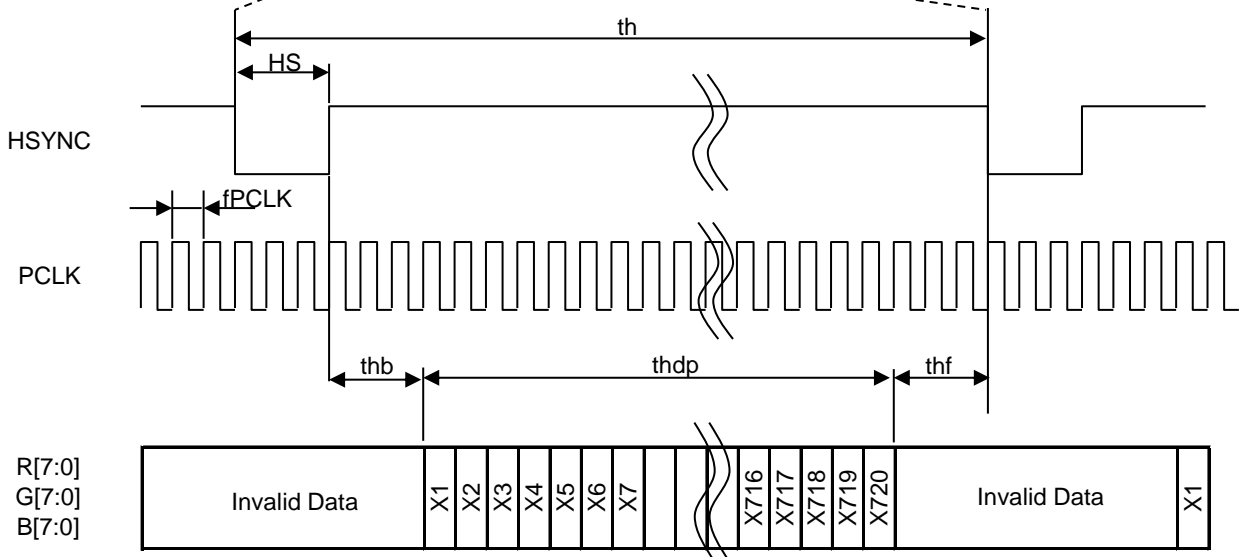

Timing Characteristics of input signals

### 9. About MIPI Interface

#### 9.1 Version

The DSI incorporated in the LCD-Driver complies with the following standards.

MIPI DSI : Version 1.1

MIPI D-PHY : Version 1.1

Data transfer mode : Video mode only.

Virtual Channel : Set to VC[1:0]=00.

It is recommended to turn DSI\_CLK off (LP mode) during the blanking period.

#### 9.2 DSI protocol

- Short packets specify the payload length using the Data Type field and are from 2 to 9 bytes in length. Short packets is used for most Command Mode commands and associated parameters.

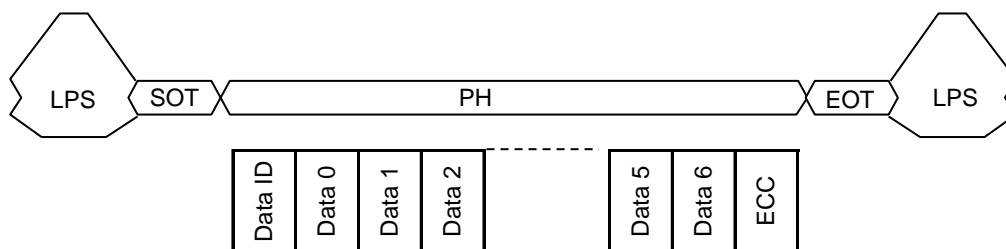

LPS : Low power state  
 SOT : Start of Transmission  
 PH : Packet Header  
 DI(Data ID) : Contain Virtual Channel Identifier and Data Type  
 ECC : Error Correction Code

- Long packets specify the payload length using a two-byte Word Count field and then the payload maybe 0 to 65,541 bytes in length. Long packets permit transmission of large blocks of pixel or other data.

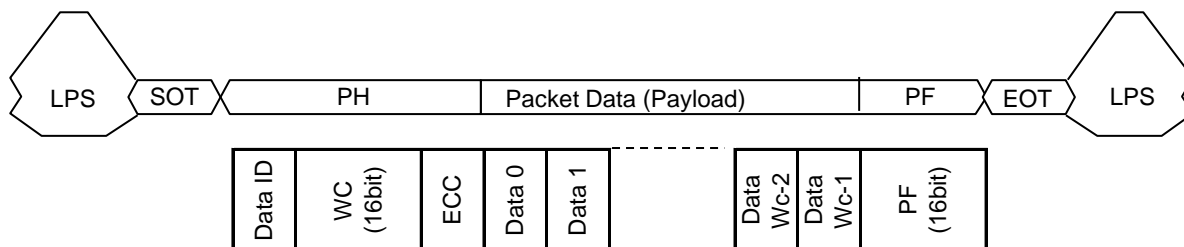

LPS : Low power state  
 SOT : Start of Transmission  
 PH : Packet Header  
 DI(Data ID) : Contain Virtual Channel Identifier and Data Type  
 WC(Word Count) : The receiver use WC to define packet end.  
 ECC : Error Correction Code  
 PF(Packet Footer) : Mean 16-bit Checksum.

### 9.3 Packet data types

LCD-Driver has the following restriction.

Generic short / Long Write Cmd is not supported.

It is only DCS Short / Long Write Cmd.

#### Processor to peripheral direction

Data Type Hex	Description	Size
01 h	Sync Event , V Sync Start (01,00,00,07)	Short
11 h	Sync Event , V Sync End (11,00,00,14)	Short
21 h	Sync Event , H Sync Start (21,00,00,12)	Short
31 h	Sync Event , H Sync End (31,00,00,01)	Short
22 h	Shut Down Peripheral Command (22,00,00,1E)	Short
32 h	Turn On Peripheral Command (32,00,00,0D)	Short
05 h	DCS WRITE , no parameters	Short
15 h	DCS WRITE , one parameters	Short
06 h	DCS READ , no parameters	Short
37 h	Set Maximum Return Packet Size	Short
08 h	End of Transmission Packet (08,0F,0F,01)	Short
09 h	Null Packet , no data	Long
19 h	Blanking Packet , no data	Long
39 h	DCS Long Write Command Packet	Long
0E h	Packed Pixel Stream , 16-bit RGB , 5-6-5 Format	Long
1E h	Packed Pixel Stream , 18-bit RGB , 6-6-6 Format	Long
2E h	Loosely Packed Pixel Stream , 18-bit RGB ,6-6-6 Format	Long
3E h	Packed Pixel Stream , 24-bit RGB , 8-8-8 Format	Long

#### Peripheral to processor direction

Data Type Hex	Description	Size
02 h	Acknowledge with Error Report	Short
1C h	DCS Long READ Response	Long

### 9.4 Packet Footer on the long packet

After Packet Data, Packet Footer is added in Long packet. Packet Footer adds CRC calculated from Packet Data as Checksum.

Checksum(2byte) = CRC(Packet Data)

$CRC = X^{16} + X^{12} + X^5 + X^0$

## 10.Sequence

## 10.1 Power-ON Sequence

PH :Packet Header

No.		Function	DNC	Command /Parameter	Type	Command/Parameter
	Power on	VCC, IOVCC On				
	MIPI signal state	Keep CN/P, D0N/P, D1N/P D2N/P,D3N/P in STOP state LP-11 (Must be set to LP-11 is all lanes of MIPI before rising edge of RESX.)				
	Wait	wait 1 msec or more				
	H/W RESET	RESX=1				
	Wait	wait 10 msec or more				
1	SLEEP OUT	Sleep out	0	11h	PH	[05 11 00 36]
	Wait	wait 200 msec or more				
2	DISPON	Display on	0	29h	PH	[05 29 00 1C]
	Wait	wait 50 msec or more				
3	Video stream					

## 10.2 Power-OFF Sequence

No.		Function	DNC	Command /Parameter	Type	Command/Parameter
1	DISPOFF	Display off	0	28h	PH	[05 28 00 06]
2	SLPIN	Sleep in	0	10h	PH	[05 10 00 2C]
	Wait	wait 120 msec or more				
3	Video signals	Video signals stop				
4	RESETB	RESX off(low)				

↓  
Power off

## 10.3 Sleep Sequence

No.		Function	DNC	Command /Parameter	Type	Command/Parameter
1	SLPIN	Sleep in	0	10h	PH	[05 10 00 2C]
	Wait	wait 120 msec or more				
2	Video signals	Video signals stop				

## 10.4 Sleep Release Sequence

No.		Function	DNC	Command /Parameter	Type	Command/Parameter
1	Video signals	Video signals start				
	Wait	wait 120 msec or more				
2	SLPOUT	Sleep out	0	11h	PH	[05 11 00 36]

### 11. External Power on/off Sequence

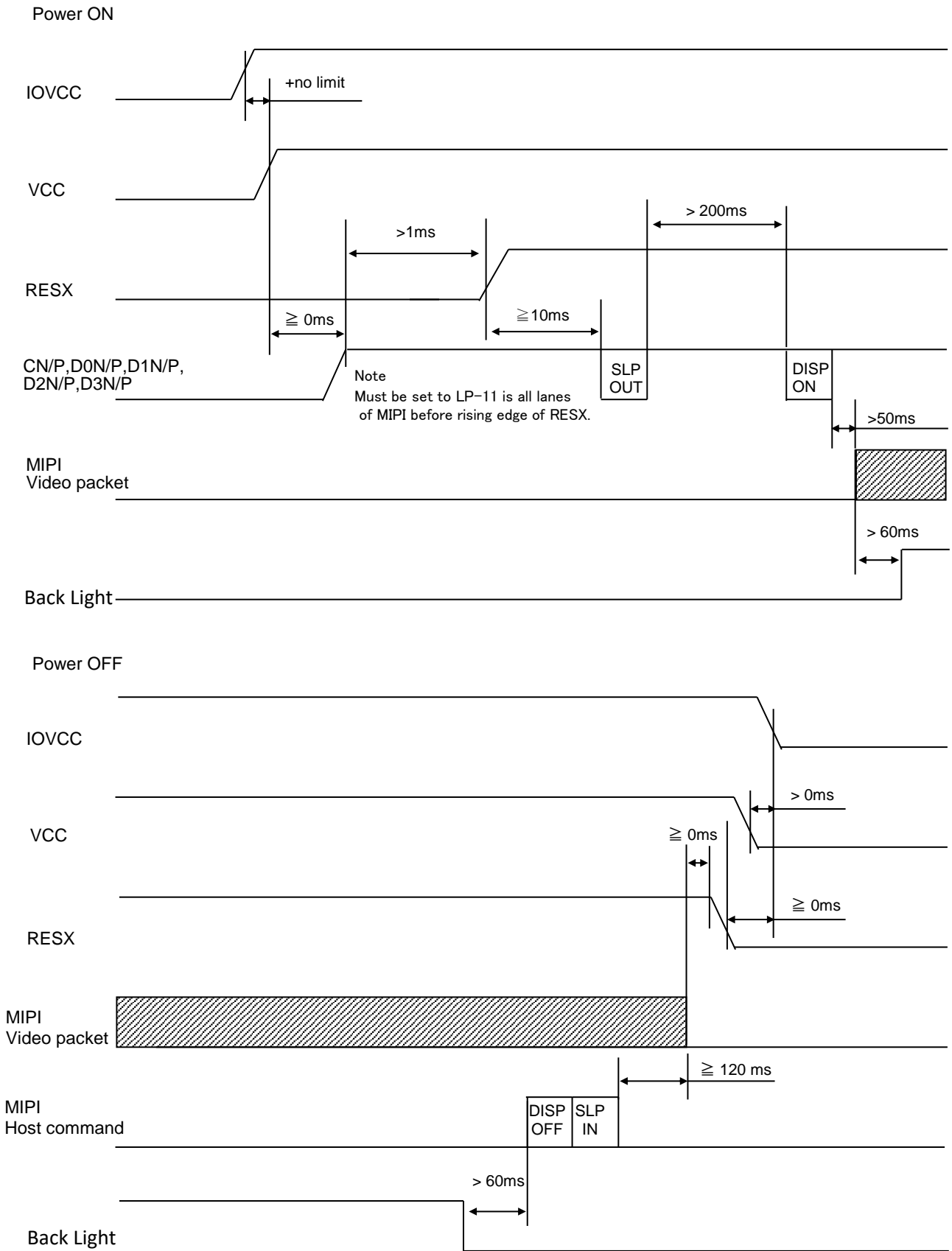

\* It is recommended that backlight is turned ON after display-on and turned OFF before entering display-off.



## 12. Characteristics

## 12.1 Optical Characteristics

(Measurement Condition)

Measuring instruments: CS2000 (KONICA MINOLTA), LCD7200 (OTSUKA ELECTRONICS), EZcontrastXL88 (ELDIM)

Driving condition: VCC=2.9V, VCCIO=1.8V, VSS=0V, Optimized VCOMDC

Backlight: IL=13.0mA

Measured temperature: Ta = 25°C

Item		Symbol	Condition	MIN	TYP	MAX	Unit	Note №	Remark
Response time	Rise time	TON	[Data]= 00h → FFh → 00h	-	-	100	ms	1	
	+ Fall time	TOFF							
Contrast ratio	Backlight ON	CR	[Data]= FF / 00h	350	700	-		2	
	Backlight OFF			-	2	-			
Viewing angle	Left	θL	[Data]= FFh / 00h CR ≥ 10	80	-	-	deg	3	
	Right	θR		80	-	-	deg		
	Up	φU		80	-	-	deg		
	Down	φD		80	-	-	deg		
White Chromaticity		x y	[Data]=FFh	White chromaticity range				4	
Center Brightness			[Data]=FFh	310	480	-	cd/m <sup>2</sup>	5	
Brightness distribution			[Data]=FFh	70	-	-	%	6	
Burn-in				No noticeable burn-in image shall be observed after 2 hours of window pattern display.				7	

\* Note number 1 to 7: Refer to the APPENDIX of "Reference Method for Measuring Optical Characteristics and Performance".

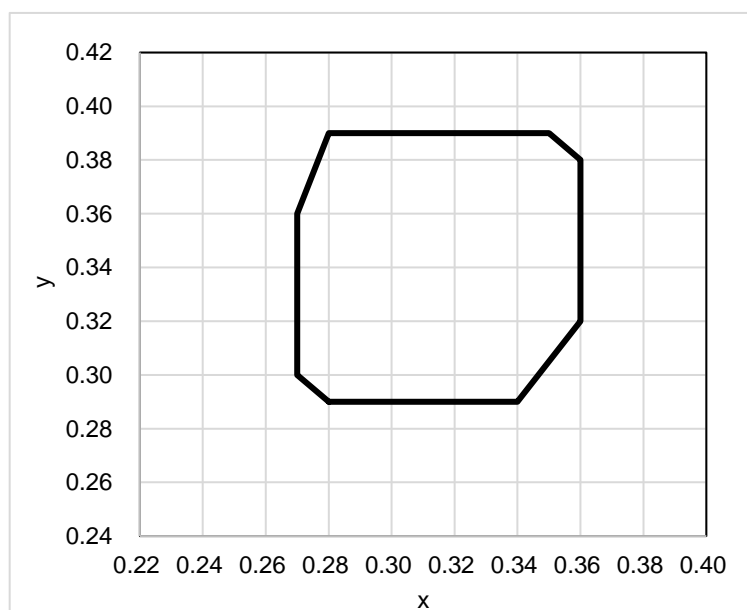

White Chromaticity Range

(White Chromaticity Range)

x	y
0.28	0.29
0.34	0.29
0.36	0.32
0.36	0.38
0.35	0.39
0.28	0.39
0.27	0.36
0.27	0.30

## 12.2 Temperature Characteristics

(Measurement Condition)

Measuring instruments: CS2000 (KONICA MINOLTA), LCD7200 (OTSUKA ELECTRONICS)

Driving condition: VCC=2.9V, VCCIO=1.8V, VSS=0V, Optimized VCOMDC

Backlight: IL=13.0mA

Item		Symbol	Specification		Remark
			Ta = -20 °C	Ta = 70 °C	
Response time	Rise time + Fall time	TON + TOFF	600 msec or less	80 msec or less	
Contrast ratio		CR	200 or more	200 or more	Backlight ON
Display Quality			No noticeable display defect or ununiformity should be observed.		

## 13. Criteria of Judgment

## 13.1 Defective Display and Screen Quality

Test Condition: Observed TFT-LCD monitor from front during operation with the following conditions

Driving Signal: Raster Patter (RGB, white, black)

Signal condition: [Data]:00h,A1h, FFh (3steps)

Observation distance: 30 cm

Illuminance: 200 to 350 lx

Backlight: IL=13.0mA

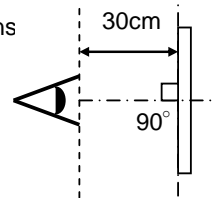

Defect item	Defect content	Criteria		
Display Quality	Line defect	Black, white or color line, 3 or more neighboring defective dots	Not exists	
	Dot defect	Uneven brightness on dot-by-dot base due to defective TFT or CF, or dust is counted as dot defect (brighter dot, darker dot)	Refer to table 1	
		High bright dot: Visible through 2% ND filter at [Data]=00h	Acceptable	
		Low bright dot: Visible through 5% ND filter at [Data]=00h Dark dot: Appear dark through white display at [Data]=A1h Invisible through 5% ND filter at [Data]=00h		
Stain	Uneven brightness (white stain, black stain etc)	Invisible through 5% ND filter at Black screen. Invisible through 1% ND filter at other screen.		
Screen Quality	Foreign particle	Point-like	$0.25\text{mm} < \varphi$	N=0
			$0.20\text{mm} < \varphi \leq 0.25\text{mm}$	$N \leq 2$
			$\varphi \leq 0.20\text{mm}$	Acceptable
	Liner	$3.0\text{mm} < \text{length and } 0.08\text{mm} < \text{width}$	N=0	
		$\text{length} \leq 3.0\text{mm or width} \leq 0.08\text{mm}$	Acceptable	
Others		Use boundary sample for judgment when necessary		

$\varphi$ (mm): Average diameter = (major axis + minor axis)/2

Permissible number: N

Table1

Area	High bright dot	Low bright dot	Dark dot	Total	Criteria
A	0	2	2	3	Permissible distance between same color bright dots (includes neighboring dots): 3 mm or more Permissible distance between same color high bright dots (includes neighboring dots): 5 mm or more
B	2	4	4	6	
Total	2	4	4	7	

<Portrait model>

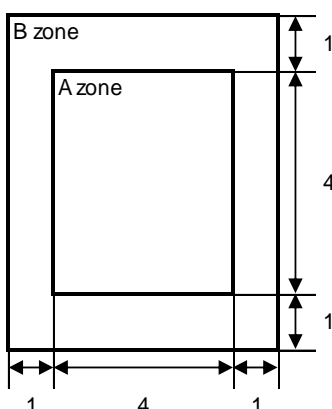

Division of A and B areas

B area: Active area

Dimensional ratio between A and B areas: 1: 4: 1

(Refer to the left figure)

## 13.2 Screen and Other Appearance

Testing conditions

Observation distance: 30 cm

Illuminance: 1200 ~ 2000 lx

Item	Criteria	Remark
Polarizer Flaw Stain Dirt Bubble Dust Dent	Ignore invisible defect when the backlight is on.	Applicable area: Active area only (Refer to the section 3.2 Outward Form)
S case	No functional defect occurs	
FPC	No functional defect occurs	

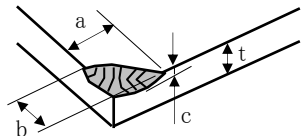
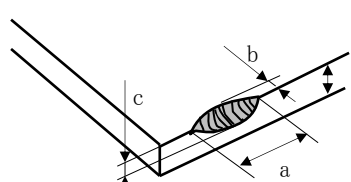
Item	Appearance	Criteria
Glass chipping	Corner area 	Unit : mm $a \leq 3$ $b \leq 3$ $c \leq t$ ( t: glass thickness) $a, b \leq 0.5$ is acceptable $n \leq 2$
	Others 	Unit : mm $a \leq 5$ $b \leq 1$ $c \leq t$ ( t: glass thickness) $a, b \leq 0.5$ is acceptable Maximum permissible number of chipping off on a side is 5.
	Progressive crack	None

## 14. Reliability Test

Test item		Test condition	number of failures / number of examinations
Durability test	High temperature storage	Ta = 80°C 240hrs	0/3
	Low temperature storage	Ta = -30°C 240hrs	0/3
	High temperature & high humidity storage	Ta = 60°C, RH = 90%, non condensing ※	0/3
	High temperature operation	Tp = 70°C 240hrs	0/3
	Low temperature operation	Tp = -20°C 240hrs	0/3
	High temperature & high humidity operation	Tp = 40°C, RH = 90%, non condensing ※	0/3
	Thermal shock storage	-30°C ↔ 80°C (30min / 30min) 100cycles	0/3
	Lightfastness	Xenon Blackpanel 63±3°C non-shower 450W/m <sup>2</sup> (300~700nm) non-operating Integral dose 800MJ/m <sup>2</sup>	0/3
Mechanical environmental test	Electrostatic discharge test (Non operation)	Confirms to EIAJ ED-4701/300, C=200pF,R=0Ω,V=±200V Each 3 times of discharge on and power supply and other terminals.	0/3
	Surface discharge test (Non operation)	C=250pF, R=100Ω, V=±12.0kV Each 5 times of discharge in both polarities on the center of screen with the case grounded.	0/3
	Vibration test	Total amplitude 1.5mm, f=10~55Hz, X,Y,Z directions for each 2 hours	0/3
	Impact test	Use TOPPAN original jig (see next page) and make an impact with peak acceleration of 1000m/s <sup>2</sup> for 6 msec with half sine-curve at 3 times to each X, Y, Z directions in conformance with JIS C 60068-2-27-2011.	0/3
Packing test	Packing vibration-proof test	Acceleration of 19.6m/s <sup>2</sup> with frequency of 10→55→10Hz, X,Y, Zdirection for each 30 minutes.	0/1packing
	Packing drop test	Drop from 75cm high. 1 time to each 6 surfaces, 3 edges, 1 corner	0/1packing

Note: Ta=ambient temperature Tp=Panel temperature

※ The profile of high temperature/humidity storage and High Temperature/humidity operation  
(Pure water of over 10MΩ·cm shall be used.)

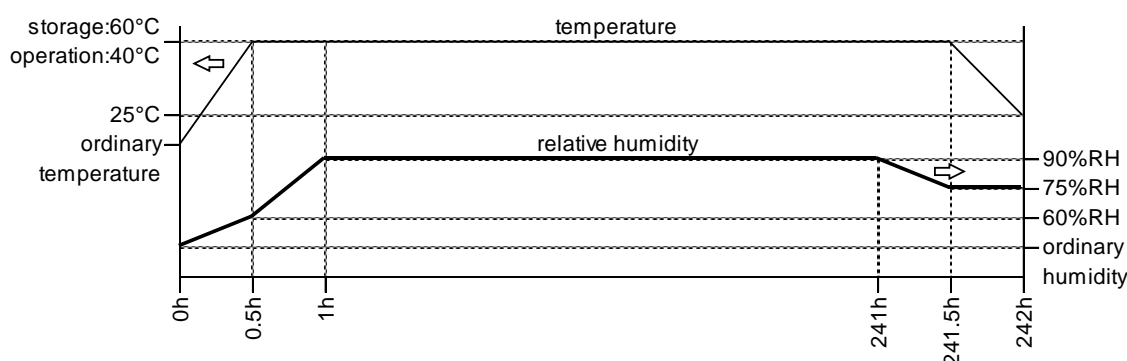
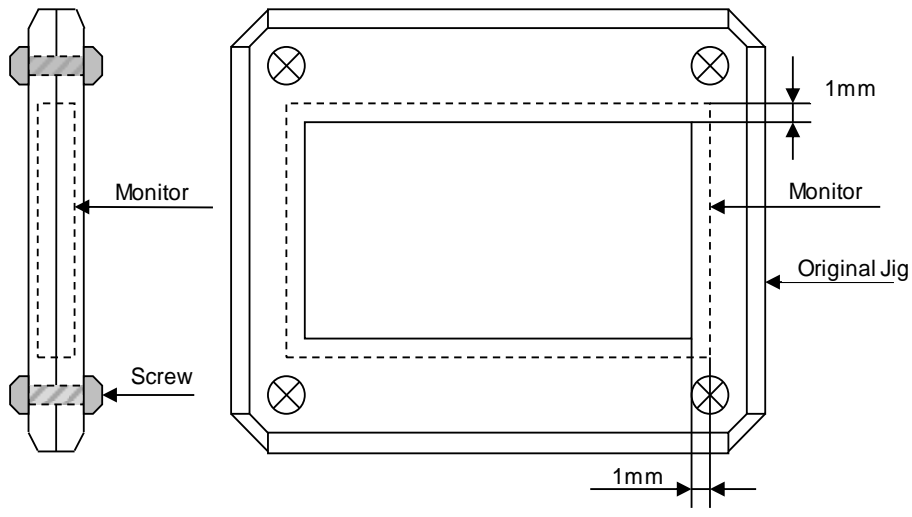

Table2. Reliability Criteria

The parameters should be measured after leaving the monitor at the ordinary temperature for 24 hours or more after the test completion.

Item	Standard	Remark
Display quality	No visible abnormality shall be seen. (Except for unevenness by POI deterioration.)	
Contrast ratio	200 or more	Backlight ON

TOPPAN Original Jig



## 15. Packing Specifications

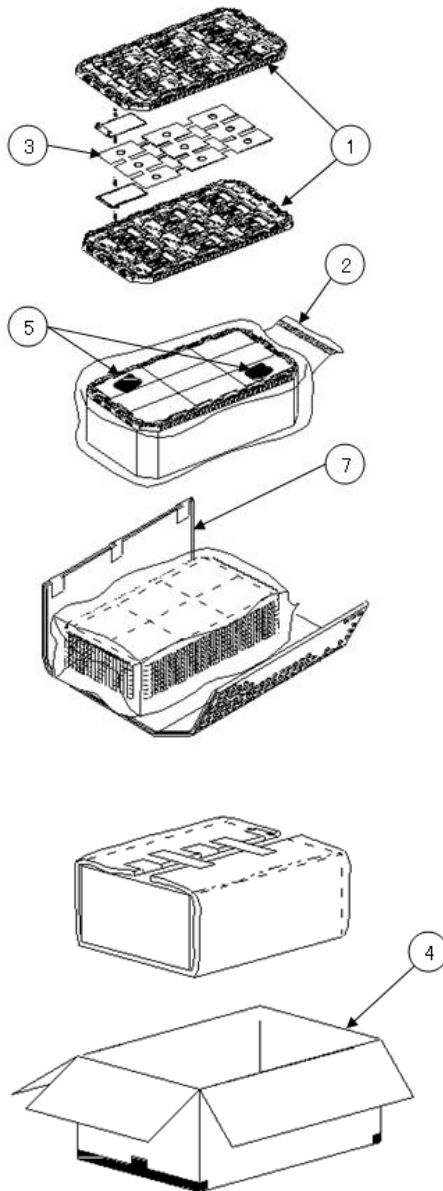

Step1. Each product is to be placed in one of the cut-outs of the tray with the display surface facing upward. (9 products per tray)  
Foam sheet is to be placed on the products in the tray.  
Each product is to be placed in one of the cut-outs of the tray with the display surface facing downward.(18products per tray)

Step2. The trays be in a stack of 8.(Rotate 180 degrees for each step)  
One empty tray is to be put on the top of stack of 8 trays.

Step3. 2 packs of moisture absorbers are to be placed on the top tray as shown in the drawing. Put piled trays into a sealing bag.

Step4. Vacuum and seal the sealing bag with the vacuum sealing machine.

Step5. The stack of trays in the sealing bag is to be wrapped with a bubble cushioning sheet.

Step6. The wrapped trays are placed in the outer carton.

Step7. Bubble cushioning sheets are to be inserted into the outer carton with same orientation. The outer carton is to be sealed in H-shape with packing tape as shown in the drawing.

Step8. The model number, quantity of products, and shipping date are to be printed on the outer carton.  
If necessary, shipping labels or impression markings are to be put on the outer carton.

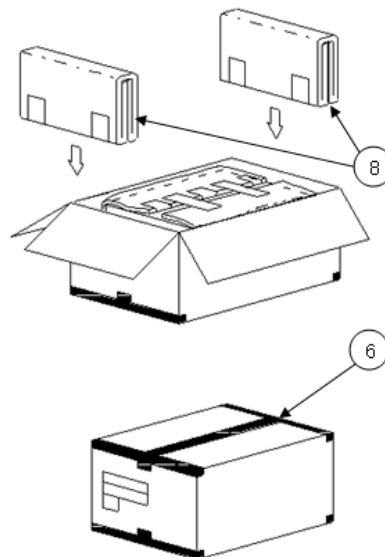

Remark: The return of packing materials is not required.

	Packing item name	Specs., Material
①	Tray	A-PET
②	Sealing bag	
③	FOAM SHEET	Anti-static polyethylene
④	Outer carton	Corrugated cardboard
⑤	Drier	Moisture absorber
⑥	Packing tape	
⑦	B SHEET A	Anti-static air bubble sheet
⑧	B SHEET B	Anti-static air bubble sheet

Dimension of extra outer carton	
D : Approx.	(356mm)
W : Approx.	(664mm)
H : Approx.	(182mm)
Quantity of products packed in one carton:	144
Gross weight : Approx.	7.0Kg

## 16. Handling Instruction

### 16.1 Cautions for Handling LCD panels



#### Caution

- (1) Do not make an impact on the LCD panel glass because it may break and you may get injured from it.
- (2) If the glass breaks, do not touch it with bare hands.  
(Fragment of broken glass may stick you or you cut yourself on it.)
- (3) If you get injured, receive adequate first aid and consult a medial doctor.
- (4) Do not let liquid crystal get into your mouth.  
(If the LCD panel glass breaks, try not let liquid crystal get into your mouth even toxic property of liquid crystal has not been confirmed.)
- (5) If liquid crystal adheres, rinse it out thoroughly.  
(If liquid crystal adheres to your cloth or skin, wipe it off with rubbing alcohol or wash it thoroughly with soap.  
If liquid crystal gets into eyes, rinse it with clean water for at least 15 minutes and consult an eye doctor.)
- (6) If you scrap this products, follow a disposal standard of industrial waste that is legally valid in the community, country or territory where you reside.
- (7) Do not connect or disconnect this product while its application products is powered on.
- (8) Do not attempt to disassemble or modify this product as it is precision component.
- (9) If a part of soldering part has been exposed, and avoid contact (short-circuit) with a metallic part of the case etc. about FPC of this model, please.  
Please insulate it with the insulating tape etc. if necessary.  
The defective operation is caused, and there is a possibility to generation of heat and the ignition.
- (10) Since excess current protection circuit is not built in this TFT module, there is the possibility that LCD module or peripheral circuit become feverish and burned in case abnormal operation is generated.  
We recommend you to add excess current protection circuit to power supply.
- (11) The devices on the FPC are damageable to electrostatic discharge, because the terminals of the devices are exposed.  
Wear grounded wrist-straps and use electrostatic neutralization blowers to prevent static charge and discharge when handling the TFT monitors.  
Designate an appropriate operating area, and set equipment, tools, and machines properly when handling this product.



#### Caution

This mark is used to indicate a precaution or an instruction which, if not correctly observed, may result in bodily injury, or material damages alone.



## 16.2 Precautions for Handling

- 1) Wear finger tips at incoming inspection and for handling the TFT monitors to keep display quality and keep the working area clean.  
Do not touch the surface of the monitor as it is easily scratched.
- 2) Wear grounded wrist-straps and use electrostatic neutralization blowers to prevent static charge and discharge when handling the TFT monitors as the LED in this TFT monitors is damageable to electrostatic discharge.  
Designate an appropriate operating area, and set equipment, tools, and machines properly when handling this product.
- 3) Avoid strong mechanical shock including knocking, hitting or dropping to the TFT monitors for protecting their glass parts.  
Do not use the TFT monitors that have been experienced dropping or strong mechanical shock.
- 4) Do not use or storage the TFT monitors at high temperature and high humidity environment.  
Particularly, never use or storage the TFT monitors at a location where condensation builds up.
- 5) Avoid using and storing TFT monitors at a location where they are exposed to direct sunlight or ultraviolet rays to prevent the LCD panels from deterioration by ultraviolet rays.
- 6) Do not stain or damage the contacts of the FPC cable .  
FPC cable needs to be inserted until it can reach to the end of connector slot.  
During insertion, make sure to keep the cable in a horizontal position to avoid an oblique insertion.  
Otherwise, it may cause poor contact or deteriorate reliability of the FPC cable.
- 7) The FPC cable is a design very weak to the bend and the pull as it is fixed with the tape.  
Do not bend or pull the FPC cable or carry the TFT monitor by holding the FPC cable.
- 8) Peel off the protective film on the TFT monitors during mounting process.  
Refer to the section 16.5 on how to peel off the protective film.  
We are not responsible for electrostatic discharge failures or other defects occur when peeling off the protective film.
- 9) It is recommended to employ the structure of which polarizer peripheral area of LCD panel being pressed by cushioning materials, in order to prevent a cause of display brightness unevenness.
- 10) By reason of this model is made by thin glass, this model LCD is breakable.  
Please apply fitting of protection LCD surface. (ex. Covered acrylic board on LCD surface)

## 16.3 Precautions for Operation

- 1) Since this TFT monitors are not equipped with light shielding for the driver IC, do not expose the driver IC to strong lights during operation as it may cause functional failures.
- 2) In case of powering up or powering off this LCD module, be sure to comply the sequence as instructed in this specification.
- 3) Do not plug in or out the FPC cable while power supply is switch on.  
Plug the FPC cable in and out while power supply is switched off.
- 4) Do not operate the TFT monitors in the strong magnetic field. It may break the TFT monitors.
- 5) Do not display a fixed image on the screen for a long time.  
Use a screen-saver or other measures to avoid a fixed image displayed on the screen for a long time.  
Otherwise, it may cause burn-in image on the screen due the characteristics of liquid crystal.

#### 16.4 Storage Condition for Shipping Cartons

(Storage environment)

- Temperature 0 to 40° C
- Humidity 60%RH or less  
No-condensing occurs under low temperature with high humidity condition.
- Atmosphere No poisonous gas that can erode electronic components and/or wiring materials should be detected.
- Time period 1 year
- Unpacking To prevent damages caused by static electricity, anti-static precautionary measures (e.g. earthing, anti-static mat) should be implemented.  
After unpack, keep product in the appropriate condition, otherwise bubble seal of Protective film may be printed on Polarizer.
- Maximum piling up 7cartons

\*Conditions to storage after unpacking

(Storage environment)

- Temperature 0 to 40° C
- Humidity 60%RH or less  
No-condensing occurs under low temperature with high humidity condition.
- Atmosphere No poisonous gas that can erode electronic components and/or wiring materials should be detected.
- Time period 1 year (Shelf life)
- Others Keep/ store away from direct sunlight  
Storage goods on original tray made by TOPPAN.

## 16.5 Precautions for Peeling off the Protective film

The followings work environment and work method are recommended to prevent the TFT monitors from static damage or adhesion of dust when peeling off the protective films.

### A) Work Environment

- a) Humidity: 50 to 70 %RH, Temperature 15 to 27° C
- b) Operators should wear conductive shoes, conductive clothes, conductive finger tips and grounded wrist-straps.  
Use an electrostatic neutralization blower.
- c) Anti-static treatment should be implemented to work area's floor.  
Use a room shielded against outside dust with sticky floor mat laid at the entrance to eliminate dirt.

### B) Work Method

The following procedures should taken to prevent the driver ICs from charging and discharging.

- a) Use an electrostatic neutralization blower to blow air on the TFT monitors to its lower right when FPC is placed at the lower right.  
Optimize direction of the blowing air and the distance between the TFT monitors and the electrostatic neutralization blower.
- b) Put an adhesive tape (Scotch tape, etc) at the lower right corner area of the protective film to prevent scratch on surface of TFT monitors.
- c) Peel off the adhesive tape slowly (spending more than 2 secs to complete) by pulling it to opposite direction.

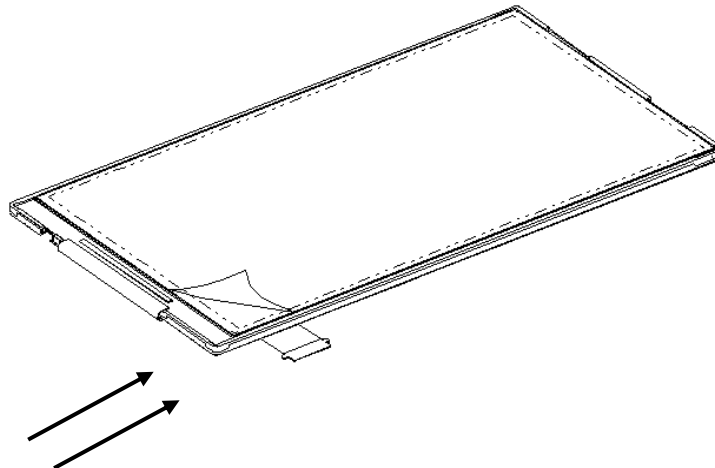

Blower wind direction  
(Set an ion blower with its adequate conditions.)

## 16.6 Warranty

TOPPAN is only liable to defective goods which is stored and used under the condition complying with this specifications and returned within 1 (one) year.

Warranty caused by manufacturing defect shall be conducted by replacement of goods or refundment at unit price.

**APPENDIX**

Reference Method for Measuring Optical Characteristics and Performance

1. Measurement Condition (Backlight ON)

Measuring instruments: CS2000(KONICA MINOLTA), LCD7200(OTSUKA ELECTRONICS),EZcontrastXL88(ELDIM)

Driving condition: Refer to the section "Optical Characteristics"

Measured temperature: 25°C unless specified

Measurement system: See the chart below. The luminance meter is placed on the normal line of measurement system.

Measurement point: At the center of the screen unless otherwise specified

Dark box at constant temperature

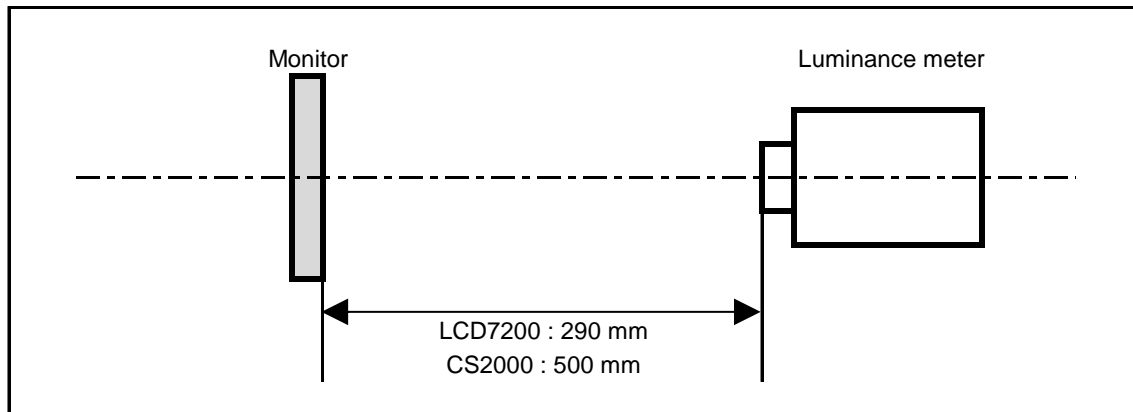

\*Measurement is made after 30 minutes of lighting of the backlight.

Measurement point: At the center point of the screen

Brightness distribution: 9 points shown in the following drawing.

<Portrait model>

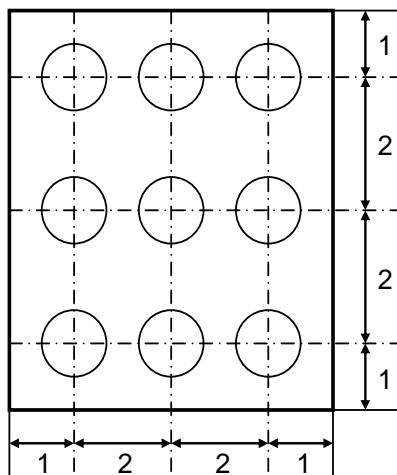

Dimensional ratio of active area

Backlight IL=13.0mA

Measurement Condition (Contrast ratio Backlight OFF only)

Measuring instruments: LCD7200(OTSUKA ELECTRONICS) , Ring Light (40,000 lx,  $\phi 58$ )

Driving condition: Refer to the section "Optical Characteristics"

Measured temperature: 25°C unless specified

Measurement system: See the chart below.

Measurement point: At the center of the screen unless otherwise specified

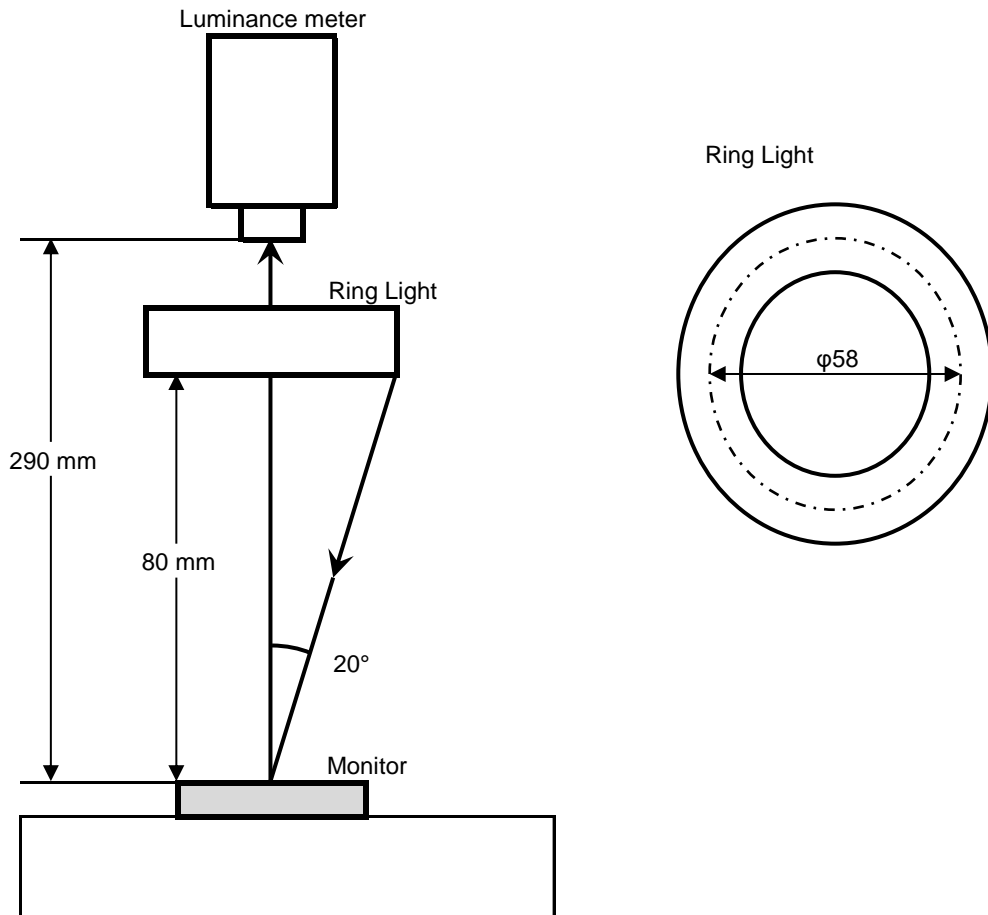

## 2. Test Method

Notice	Item	Test method	Measuring instrument	Remark
1	Response time	<p>Measure output signal waveform by the luminance meter when raster of window pattern is changed from white to black and from black to white.</p>	LCD7200	Black display [Data]=00h White display [Data]=FFh TON Rise time TOFF Fall time
2	Contrast ratio	<p>Measure maximum luminance Y1([Data]=FFh) and minimum luminance Y2([Data]=00h) at the center of the screen by displaying raster or window pattern. Then calculate the ratio between these two values.</p> <p>Contrast ratio = <math>Y1/Y2</math></p> <p>Diameter of measuring point: 7.8mmφ(CS2000)            Diameter of measuring point: 3mmφ(LCD7200)</p>	CS2000 LCD7200	Backlight ON Backlight OFF
3	Viewing angle Horizontalθ Verticalφ	Move the luminance meter from right to left and up and down and determine the angles where contrast ratio is 10.	EZcontrastXL88	
4	White chromaticity	<p>Measure chromaticity coordinates x and y of CIE1931 colorimetric system at [Data] = FFh</p> <p>Color matching function: 2°view            measurement angle: 1°</p>	CS2000	
5	Center brightness	Measure the brightness at the center of the screen.	CS2000	
6	Brightness distribution	<p>(Brightness distribution) = <math>100 \times B/A \%</math></p> <p>A : max. brightness of the 9 points            B : min. brightness of the 9 points</p>	CS2000	
7	Burn-in	Visually check burn-in image on the screen after 2 hours of "window display" ([Data]=00h/FFh).		At optimized VCOMDC

# DATA MODUL

Passion Displayed



## All good things come in threes:

With **Hardware**, **Software** and **Services**, we realise unique display solutions that turn your ideas into reality.

[www.data-modul.com](http://www.data-modul.com)

