

Specification

G057QAN01.1

5.7" - 320x240 – RGB/TTL

Spec Revision: 0.2
Revision Date: 05.11.2024

Note: This specification is subject to change without prior notice



AUO Display+

Preliminary Specification

Final Specification

Module	5.7 Inch Color TFT-LCD
Model Name	G057QAN01.1

Customer	Date
_____	_____
Checked & Approved by	
_____	_____



Approved by	Date
Castor Chan	2024/11/05
Prepared by	
Emma Lin	2024/11/05
General Display Business Unit / AUO Display Plus Corporation	

Contents

1. Operating Precautions	6
2. General Description	7
2.1 Display Characteristics	7
2.2 Optical Characteristics	8
3. Functional Block Diagram	11
4. Absolute Maximum Ratings	12
4.1 Absolute Ratings of TFT LCD	12
4.2 Absolute Ratings of Environment	12
5. Electrical Characteristics	13
5.1 TFT-LCD Driving	13
5.2 Backlight Unit Driving	14
6. Signal Characteristic	15
6.1 Pixel Format Image	15
6.2 Scanning Direction	15
6.3 The Input Data Format	16
6.4 TFT- LCD Interface Signal Description	17
6.5 TFT- LCD Interface Timing	18
6.6 LED Backlight Unit Interface Signal Description	19
6.7 Power ON/OFF Sequence	20
7. Connector & Pin Assignment	21
7.1 TFT- LCD Signal (CN1): LCD Connector	21
7.2 LED Backlight Unit (CN2): Backlight Connector	21
7.3 LED Light Bar Input (CN3): Light Bar Connector	21
7.4 PIN 1 definition of CN1 and CN2	22
7.5 PIN 1 definition of CN3	22
8. Reliability Test Criteria	23
9. Mechanical Characteristics	24
10. Label and Packaging	25
10.1 Shipping Label (on the rear side of TFT-LCD display)	25
10.2 Carton Package	25
11 Safety	26
11.1 Keen Edge Requirements	26
11.2 Materials	26
11.3 Capacitors	26
11.4 National Test Lab Requirement	26

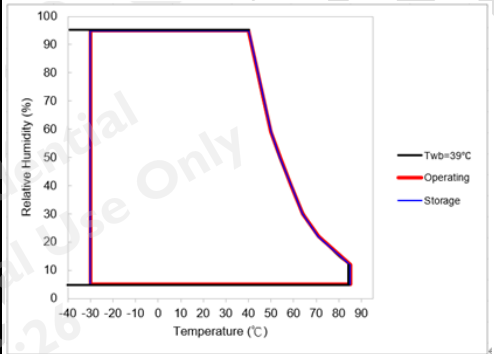
Record of Revision

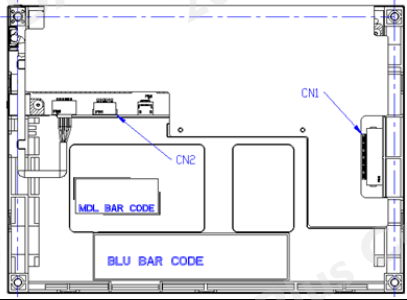
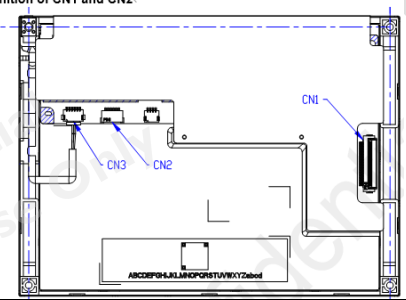
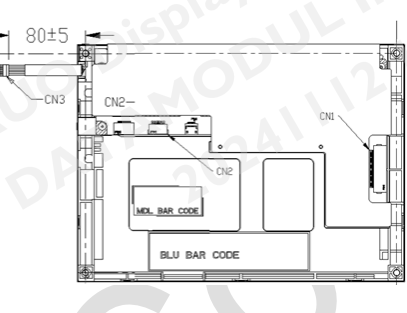
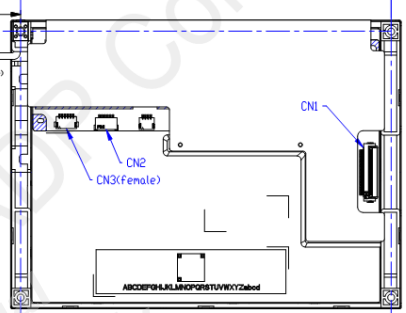
Version and Date	Page	Old description	New Description																																																																																																																																																																																																																		
0.0 2024/03/26	All		First draft of Preliminary specification.																																																																																																																																																																																																																		
0.1 2024/09/10	5	Typical Power Consumption ¹⁾ Watt ¹⁾ TBD ¹⁾ @ All white pattern, Full Load and VLED=12V ¹⁾	Typical Power Consumption ¹⁾ Watt ¹⁾ 2.21W (LCD: 0.09W / LED BLU: 2.12W) ¹⁾ @ All white pattern, Full Load and VLED=12V ¹⁾																																																																																																																																																																																																																		
		Viewing Angle ¹⁾ degree ¹⁾ Horizontal (Right) ¹⁾ CR = 10 70 ¹⁾ 89 ¹⁾ degree ¹⁾ Vertical (Upper) ¹⁾ CR = 10 70 ¹⁾ 89 ¹⁾ Note 6 ¹⁾	Viewing Angle ¹⁾ degree ¹⁾ Horizontal (Right) ¹⁾ CR = 10 80 ¹⁾ 89 ¹⁾ degree ¹⁾ Vertical (Upper) ¹⁾ CR = 10 80 ¹⁾ 89 ¹⁾ Note 6 ¹⁾																																																																																																																																																																																																																		
			Add temperature and Humidity curve 																																																																																																																																																																																																																		
	12	5.2.1 Parameter guideline for LED ¹⁾ Following characteristics are measured under stable condition at 25°C (Room Temperature). ¹⁾	5.2.1 Parameter guideline for LED ¹⁾ Following characteristics are measured under stable condition at 25°C (Room Temperature). ¹⁾																																																																																																																																																																																																																		
		<table border="1"> <thead> <tr> <th>Symbol¹⁾</th> <th>Parameter¹⁾</th> <th>Min¹⁾</th> <th>Typ¹⁾</th> <th>Max¹⁾</th> <th>Units¹⁾</th> <th>Remark¹⁾</th> </tr> </thead> <tbody> <tr> <td>V_{LED}¹⁾</td> <td>Input Voltage¹⁾</td> <td>9¹⁾</td> <td>12¹⁾</td> <td>20¹⁾</td> <td>Volt¹⁾</td> <td></td> </tr> <tr> <td>I_{LED}¹⁾</td> <td>Input Current¹⁾</td> <td>—¹⁾</td> <td>0.15¹⁾</td> <td>0.16¹⁾</td> <td>A¹⁾</td> <td>V_{LED} = 12V, D_{DIM} = 100%¹⁾</td> </tr> <tr> <td>P_{LED}¹⁾</td> <td>Power Consumption¹⁾</td> <td>—¹⁾</td> <td>1.81¹⁾</td> <td>1.96¹⁾</td> <td>W¹⁾</td> <td>V_{LED} = 12V, D_{DIM} = 100%¹⁾</td> </tr> <tr> <td>I_{rush,LED}¹⁾</td> <td>Inrush Current¹⁾</td> <td>—¹⁾</td> <td>—¹⁾</td> <td>1.5¹⁾</td> <td>A¹⁾</td> <td>V_{LED} = 12V, D_{DIM} = 100%¹⁾</td> </tr> <tr> <td>V_{PWM DIM}¹⁾</td> <td>Dimming control Voltage High¹⁾</td> <td>2.0¹⁾</td> <td>3.3¹⁾</td> <td>5¹⁾</td> <td>Volt¹⁾</td> <td></td> </tr> <tr> <td></td> <td>Dimming control Voltage Low¹⁾</td> <td>—¹⁾</td> <td>—¹⁾</td> <td>0.15¹⁾</td> <td>Volt¹⁾</td> <td>Note 1, 2¹⁾</td> </tr> <tr> <td>F_{PWM}¹⁾</td> <td>Dimming Frequency¹⁾</td> <td>200¹⁾</td> <td>—¹⁾</td> <td>25K¹⁾</td> <td>Hz¹⁾</td> <td></td> </tr> <tr> <td>D_{DIM}¹⁾</td> <td>Dimming duty cycle¹⁾</td> <td>1¹⁾</td> <td>—¹⁾</td> <td>100¹⁾</td> <td>%¹⁾</td> <td></td> </tr> <tr> <td>V_{LED On/Off}¹⁾</td> <td>On Control Voltage¹⁾</td> <td>2¹⁾</td> <td>3.3¹⁾</td> <td>5¹⁾</td> <td>Volt¹⁾</td> <td>Note 3, 4¹⁾</td> </tr> <tr> <td></td> <td>Off Control Voltage¹⁾</td> <td>—¹⁾</td> <td>—¹⁾</td> <td>0.6¹⁾</td> <td>Volt¹⁾</td> <td></td> </tr> <tr> <td>I_F¹⁾</td> <td>LED Forward Current¹⁾</td> <td>—¹⁾</td> <td>70¹⁾</td> <td>—¹⁾</td> <td>mA¹⁾</td> <td>T_a = 25°C¹⁾</td> </tr> <tr> <td></td> <td></td> <td>—¹⁾</td> <td>—¹⁾</td> <td>—¹⁾</td> <td>mA¹⁾</td> <td>T_a = 250°C¹⁾</td> </tr> <tr> <td>V_F¹⁾</td> <td>LED Forward Voltage¹⁾</td> <td>22.4¹⁾</td> <td>24¹⁾</td> <td>26.4¹⁾</td> <td>Volt¹⁾</td> <td>IF = 70mA, T_a = 25°C¹⁾</td> </tr> <tr> <td></td> <td></td> <td>—¹⁾</td> <td>—¹⁾</td> <td>—¹⁾</td> <td>Volt¹⁾</td> <td>IF = 70mA, T_a = 85°C¹⁾</td> </tr> <tr> <td></td> <td>Operating Life¹⁾</td> <td>50,000¹⁾</td> <td>—¹⁾</td> <td>—¹⁾</td> <td>Hrs¹⁾</td> <td>Note 5, 6, 7¹⁾</td> </tr> </tbody> </table>	Symbol ¹⁾	Parameter ¹⁾	Min ¹⁾	Typ ¹⁾	Max ¹⁾	Units ¹⁾	Remark ¹⁾	V _{LED} ¹⁾	Input Voltage ¹⁾	9 ¹⁾	12 ¹⁾	20 ¹⁾	Volt ¹⁾		I _{LED} ¹⁾	Input Current ¹⁾	— ¹⁾	0.15 ¹⁾	0.16 ¹⁾	A ¹⁾	V _{LED} = 12V, D _{DIM} = 100% ¹⁾	P _{LED} ¹⁾	Power Consumption ¹⁾	— ¹⁾	1.81 ¹⁾	1.96 ¹⁾	W ¹⁾	V _{LED} = 12V, D _{DIM} = 100% ¹⁾	I _{rush,LED} ¹⁾	Inrush Current ¹⁾	— ¹⁾	— ¹⁾	1.5 ¹⁾	A ¹⁾	V _{LED} = 12V, D _{DIM} = 100% ¹⁾	V _{PWM DIM} ¹⁾	Dimming control Voltage High ¹⁾	2.0 ¹⁾	3.3 ¹⁾	5 ¹⁾	Volt ¹⁾			Dimming control Voltage Low ¹⁾	— ¹⁾	— ¹⁾	0.15 ¹⁾	Volt ¹⁾	Note 1, 2 ¹⁾	F _{PWM} ¹⁾	Dimming Frequency ¹⁾	200 ¹⁾	— ¹⁾	25K ¹⁾	Hz ¹⁾		D _{DIM} ¹⁾	Dimming duty cycle ¹⁾	1 ¹⁾	— ¹⁾	100 ¹⁾	% ¹⁾		V _{LED On/Off} ¹⁾	On Control Voltage ¹⁾	2 ¹⁾	3.3 ¹⁾	5 ¹⁾	Volt ¹⁾	Note 3, 4 ¹⁾		Off Control Voltage ¹⁾	— ¹⁾	— ¹⁾	0.6 ¹⁾	Volt ¹⁾		I _F ¹⁾	LED Forward Current ¹⁾	— ¹⁾	70 ¹⁾	— ¹⁾	mA ¹⁾	T _a = 25°C ¹⁾			— ¹⁾	— ¹⁾	— ¹⁾	mA ¹⁾	T _a = 250°C ¹⁾	V _F ¹⁾	LED Forward Voltage ¹⁾	22.4 ¹⁾	24 ¹⁾	26.4 ¹⁾	Volt ¹⁾	IF = 70mA, T _a = 25°C ¹⁾			— ¹⁾	— ¹⁾	— ¹⁾	Volt ¹⁾	IF = 70mA, T _a = 85°C ¹⁾		Operating Life ¹⁾	50,000 ¹⁾	— ¹⁾	— ¹⁾	Hrs ¹⁾	Note 5, 6, 7 ¹⁾	<table border="1"> <thead> <tr> <th>Symbol¹⁾</th> <th>Parameter¹⁾</th> <th>Min¹⁾</th> <th>Typ¹⁾</th> <th>Max¹⁾</th> <th>Units¹⁾</th> <th>Remark¹⁾</th> </tr> </thead> <tbody> <tr> <td>V_{LED}¹⁾</td> <td>Input Voltage¹⁾</td> <td>9¹⁾</td> <td>12¹⁾</td> <td>20¹⁾</td> <td>Volt¹⁾</td> <td></td> </tr> <tr> <td>I_{LED}¹⁾</td> <td>Input Current¹⁾</td> <td>—¹⁾</td> <td>0.15¹⁾</td> <td>0.16¹⁾</td> <td>A¹⁾</td> <td>V_{LED} = 12V, D_{DIM} = 100%¹⁾</td> </tr> <tr> <td>P_{LED}¹⁾</td> <td>Power Consumption¹⁾</td> <td>—¹⁾</td> <td>2.12¹⁾</td> <td>2.23¹⁾</td> <td>W¹⁾</td> <td>V_{LED} = 12V, D_{DIM} = 100%¹⁾</td> </tr> <tr> <td>I_{rush,LED}¹⁾</td> <td>Inrush Current¹⁾</td> <td>—¹⁾</td> <td>—¹⁾</td> <td>1.5¹⁾</td> <td>A¹⁾</td> <td>V_{LED} = 12V, D_{DIM} = 100%¹⁾</td> </tr> <tr> <td>V_{PWM DIM}¹⁾</td> <td>Dimming control Voltage High¹⁾</td> <td>2.0¹⁾</td> <td>3.3¹⁾</td> <td>5¹⁾</td> <td>Volt¹⁾</td> <td></td> </tr> <tr> <td></td> <td>Dimming control Voltage Low¹⁾</td> <td>—¹⁾</td> <td>—¹⁾</td> <td>0.15¹⁾</td> <td>Volt¹⁾</td> <td>Note 1, 2¹⁾</td> </tr> <tr> <td>F_{PWM}¹⁾</td> <td>Dimming Frequency¹⁾</td> <td>200¹⁾</td> <td>—¹⁾</td> <td>25K¹⁾</td> <td>Hz¹⁾</td> <td></td> </tr> <tr> <td>D_{DIM}¹⁾</td> <td>Dimming duty cycle¹⁾</td> <td>1¹⁾</td> <td>—¹⁾</td> <td>100¹⁾</td> <td>%¹⁾</td> <td></td> </tr> <tr> <td>V_{LED On/Off}¹⁾</td> <td>On Control Voltage¹⁾</td> <td>2¹⁾</td> <td>3.3¹⁾</td> <td>5¹⁾</td> <td>Volt¹⁾</td> <td>Note 3, 4¹⁾</td> </tr> <tr> <td></td> <td>Off Control Voltage¹⁾</td> <td>—¹⁾</td> <td>—¹⁾</td> <td>0.6¹⁾</td> <td>Volt¹⁾</td> <td></td> </tr> <tr> <td>I_F¹⁾</td> <td>LED Forward Current¹⁾</td> <td>—¹⁾</td> <td>80¹⁾</td> <td>—¹⁾</td> <td>mA¹⁾</td> <td>T_a = 250°C¹⁾</td> </tr> <tr> <td>V_F¹⁾</td> <td>LED Forward Voltage¹⁾</td> <td>22.4¹⁾</td> <td>23.6¹⁾</td> <td>24.8¹⁾</td> <td>Volt¹⁾</td> <td>IF = 80mA, T_a = 25°C¹⁾</td> </tr> <tr> <td></td> <td>Operating Life¹⁾</td> <td>50,000¹⁾</td> <td>—¹⁾</td> <td>—¹⁾</td> <td>Hrs¹⁾</td> <td>Note 5, 6, 7¹⁾</td> </tr> </tbody> </table> <p>Note 7: The test condition is 80mA in 25°C room temperature¹⁾</p>	Symbol ¹⁾	Parameter ¹⁾	Min ¹⁾	Typ ¹⁾	Max ¹⁾	Units ¹⁾	Remark ¹⁾	V _{LED} ¹⁾	Input Voltage ¹⁾	9 ¹⁾	12 ¹⁾	20 ¹⁾	Volt ¹⁾		I _{LED} ¹⁾	Input Current ¹⁾	— ¹⁾	0.15 ¹⁾	0.16 ¹⁾	A ¹⁾	V _{LED} = 12V, D _{DIM} = 100% ¹⁾	P _{LED} ¹⁾	Power Consumption ¹⁾	— ¹⁾	2.12 ¹⁾	2.23 ¹⁾	W ¹⁾	V _{LED} = 12V, D _{DIM} = 100% ¹⁾	I _{rush,LED} ¹⁾	Inrush Current ¹⁾	— ¹⁾	— ¹⁾	1.5 ¹⁾	A ¹⁾	V _{LED} = 12V, D _{DIM} = 100% ¹⁾	V _{PWM DIM} ¹⁾	Dimming control Voltage High ¹⁾	2.0 ¹⁾	3.3 ¹⁾	5 ¹⁾	Volt ¹⁾			Dimming control Voltage Low ¹⁾	— ¹⁾	— ¹⁾	0.15 ¹⁾	Volt ¹⁾	Note 1, 2 ¹⁾	F _{PWM} ¹⁾	Dimming Frequency ¹⁾	200 ¹⁾	— ¹⁾	25K ¹⁾	Hz ¹⁾		D _{DIM} ¹⁾	Dimming duty cycle ¹⁾	1 ¹⁾	— ¹⁾	100 ¹⁾	% ¹⁾		V _{LED On/Off} ¹⁾	On Control Voltage ¹⁾	2 ¹⁾	3.3 ¹⁾	5 ¹⁾	Volt ¹⁾	Note 3, 4 ¹⁾		Off Control Voltage ¹⁾	— ¹⁾	— ¹⁾	0.6 ¹⁾	Volt ¹⁾		I _F ¹⁾	LED Forward Current ¹⁾	— ¹⁾	80 ¹⁾	— ¹⁾	mA ¹⁾	T _a = 250°C ¹⁾	V _F ¹⁾	LED Forward Voltage ¹⁾	22.4 ¹⁾	23.6 ¹⁾	24.8 ¹⁾	Volt ¹⁾	IF = 80mA, T _a = 25°C ¹⁾		Operating Life ¹⁾	50,000 ¹⁾	— ¹⁾	— ¹⁾	Hrs ¹⁾	Note 5, 6, 7 ¹⁾
Symbol ¹⁾	Parameter ¹⁾	Min ¹⁾	Typ ¹⁾	Max ¹⁾	Units ¹⁾	Remark ¹⁾																																																																																																																																																																																																															
V _{LED} ¹⁾	Input Voltage ¹⁾	9 ¹⁾	12 ¹⁾	20 ¹⁾	Volt ¹⁾																																																																																																																																																																																																																
I _{LED} ¹⁾	Input Current ¹⁾	— ¹⁾	0.15 ¹⁾	0.16 ¹⁾	A ¹⁾	V _{LED} = 12V, D _{DIM} = 100% ¹⁾																																																																																																																																																																																																															
P _{LED} ¹⁾	Power Consumption ¹⁾	— ¹⁾	1.81 ¹⁾	1.96 ¹⁾	W ¹⁾	V _{LED} = 12V, D _{DIM} = 100% ¹⁾																																																																																																																																																																																																															
I _{rush,LED} ¹⁾	Inrush Current ¹⁾	— ¹⁾	— ¹⁾	1.5 ¹⁾	A ¹⁾	V _{LED} = 12V, D _{DIM} = 100% ¹⁾																																																																																																																																																																																																															
V _{PWM DIM} ¹⁾	Dimming control Voltage High ¹⁾	2.0 ¹⁾	3.3 ¹⁾	5 ¹⁾	Volt ¹⁾																																																																																																																																																																																																																
	Dimming control Voltage Low ¹⁾	— ¹⁾	— ¹⁾	0.15 ¹⁾	Volt ¹⁾	Note 1, 2 ¹⁾																																																																																																																																																																																																															
F _{PWM} ¹⁾	Dimming Frequency ¹⁾	200 ¹⁾	— ¹⁾	25K ¹⁾	Hz ¹⁾																																																																																																																																																																																																																
D _{DIM} ¹⁾	Dimming duty cycle ¹⁾	1 ¹⁾	— ¹⁾	100 ¹⁾	% ¹⁾																																																																																																																																																																																																																
V _{LED On/Off} ¹⁾	On Control Voltage ¹⁾	2 ¹⁾	3.3 ¹⁾	5 ¹⁾	Volt ¹⁾	Note 3, 4 ¹⁾																																																																																																																																																																																																															
	Off Control Voltage ¹⁾	— ¹⁾	— ¹⁾	0.6 ¹⁾	Volt ¹⁾																																																																																																																																																																																																																
I _F ¹⁾	LED Forward Current ¹⁾	— ¹⁾	70 ¹⁾	— ¹⁾	mA ¹⁾	T _a = 25°C ¹⁾																																																																																																																																																																																																															
		— ¹⁾	— ¹⁾	— ¹⁾	mA ¹⁾	T _a = 250°C ¹⁾																																																																																																																																																																																																															
V _F ¹⁾	LED Forward Voltage ¹⁾	22.4 ¹⁾	24 ¹⁾	26.4 ¹⁾	Volt ¹⁾	IF = 70mA, T _a = 25°C ¹⁾																																																																																																																																																																																																															
		— ¹⁾	— ¹⁾	— ¹⁾	Volt ¹⁾	IF = 70mA, T _a = 85°C ¹⁾																																																																																																																																																																																																															
	Operating Life ¹⁾	50,000 ¹⁾	— ¹⁾	— ¹⁾	Hrs ¹⁾	Note 5, 6, 7 ¹⁾																																																																																																																																																																																																															
Symbol ¹⁾	Parameter ¹⁾	Min ¹⁾	Typ ¹⁾	Max ¹⁾	Units ¹⁾	Remark ¹⁾																																																																																																																																																																																																															
V _{LED} ¹⁾	Input Voltage ¹⁾	9 ¹⁾	12 ¹⁾	20 ¹⁾	Volt ¹⁾																																																																																																																																																																																																																
I _{LED} ¹⁾	Input Current ¹⁾	— ¹⁾	0.15 ¹⁾	0.16 ¹⁾	A ¹⁾	V _{LED} = 12V, D _{DIM} = 100% ¹⁾																																																																																																																																																																																																															
P _{LED} ¹⁾	Power Consumption ¹⁾	— ¹⁾	2.12 ¹⁾	2.23 ¹⁾	W ¹⁾	V _{LED} = 12V, D _{DIM} = 100% ¹⁾																																																																																																																																																																																																															
I _{rush,LED} ¹⁾	Inrush Current ¹⁾	— ¹⁾	— ¹⁾	1.5 ¹⁾	A ¹⁾	V _{LED} = 12V, D _{DIM} = 100% ¹⁾																																																																																																																																																																																																															
V _{PWM DIM} ¹⁾	Dimming control Voltage High ¹⁾	2.0 ¹⁾	3.3 ¹⁾	5 ¹⁾	Volt ¹⁾																																																																																																																																																																																																																
	Dimming control Voltage Low ¹⁾	— ¹⁾	— ¹⁾	0.15 ¹⁾	Volt ¹⁾	Note 1, 2 ¹⁾																																																																																																																																																																																																															
F _{PWM} ¹⁾	Dimming Frequency ¹⁾	200 ¹⁾	— ¹⁾	25K ¹⁾	Hz ¹⁾																																																																																																																																																																																																																
D _{DIM} ¹⁾	Dimming duty cycle ¹⁾	1 ¹⁾	— ¹⁾	100 ¹⁾	% ¹⁾																																																																																																																																																																																																																
V _{LED On/Off} ¹⁾	On Control Voltage ¹⁾	2 ¹⁾	3.3 ¹⁾	5 ¹⁾	Volt ¹⁾	Note 3, 4 ¹⁾																																																																																																																																																																																																															
	Off Control Voltage ¹⁾	— ¹⁾	— ¹⁾	0.6 ¹⁾	Volt ¹⁾																																																																																																																																																																																																																
I _F ¹⁾	LED Forward Current ¹⁾	— ¹⁾	80 ¹⁾	— ¹⁾	mA ¹⁾	T _a = 250°C ¹⁾																																																																																																																																																																																																															
V _F ¹⁾	LED Forward Voltage ¹⁾	22.4 ¹⁾	23.6 ¹⁾	24.8 ¹⁾	Volt ¹⁾	IF = 80mA, T _a = 25°C ¹⁾																																																																																																																																																																																																															
	Operating Life ¹⁾	50,000 ¹⁾	— ¹⁾	— ¹⁾	Hrs ¹⁾	Note 5, 6, 7 ¹⁾																																																																																																																																																																																																															
		7.1 TFT-LCD Signal (CN1): LCD Connector	Delete Pin define, it was shown on section 6.4																																																																																																																																																																																																																		
		<table border="1"> <tr> <td>Manufacturer</td> <td>Starconn</td> </tr> <tr> <td>Connector Model Number</td> <td>089H133-000100-G2-R, compatible with MSA-98375-33Y902 & ELCO 08-8210-033-340-800¹⁾</td> </tr> </table> <table border="1"> <thead> <tr> <th>Pin#</th> <th>Symbol</th> <th>Pin#</th> <th>Symbol</th> <th>Pin#</th> <th>Symbol</th> </tr> </thead> <tbody> <tr><td>1</td><td>GND</td><td>12</td><td>GND</td><td>23</td><td>B3</td></tr> <tr><td>2</td><td>DOTCLK</td><td>13</td><td>G0</td><td>24</td><td>B4</td></tr> <tr><td>3</td><td>NC</td><td>14</td><td>G1</td><td>25</td><td>B5</td></tr> <tr><td>4</td><td>NC</td><td>15</td><td>G2</td><td>26</td><td>GND</td></tr> <tr><td>5</td><td>GND</td><td>16</td><td>G3</td><td>27</td><td>DE</td></tr> <tr><td>6</td><td>R0</td><td>17</td><td>G4</td><td>28</td><td>VDD</td></tr> <tr><td>7</td><td>R1</td><td>18</td><td>G5</td><td>29</td><td>VDD</td></tr> <tr><td>8</td><td>R2</td><td>19</td><td>GND</td><td>30</td><td>RL</td></tr> <tr><td>9</td><td>R3</td><td>20</td><td>B0</td><td>31</td><td>UD</td></tr> <tr><td>10</td><td>R4</td><td>21</td><td>B1</td><td>32</td><td>NC</td></tr> <tr><td>11</td><td>R5</td><td>22</td><td>B2</td><td>33</td><td>GND</td></tr> </tbody> </table>	Manufacturer	Starconn	Connector Model Number	089H133-000100-G2-R, compatible with MSA-98375-33Y902 & ELCO 08-8210-033-340-800 ¹⁾	Pin#	Symbol	Pin#	Symbol	Pin#	Symbol	1	GND	12	GND	23	B3	2	DOTCLK	13	G0	24	B4	3	NC	14	G1	25	B5	4	NC	15	G2	26	GND	5	GND	16	G3	27	DE	6	R0	17	G4	28	VDD	7	R1	18	G5	29	VDD	8	R2	19	GND	30	RL	9	R3	20	B0	31	UD	10	R4	21	B1	32	NC	11	R5	22	B2	33	GND	<table border="1"> <tr> <td>Manufacturer¹⁾</td> <td>Starconn¹⁾</td> </tr> <tr> <td>Connector Model Number¹⁾</td> <td>089H133-000100-G2-R, compatible with MSA-98375-33Y902 & ELCO 08-8210-033-340-800¹⁾</td> </tr> </table>	Manufacturer ¹⁾	Starconn ¹⁾	Connector Model Number ¹⁾	089H133-000100-G2-R, compatible with MSA-98375-33Y902 & ELCO 08-8210-033-340-800 ¹⁾																																																																																																																																		
Manufacturer	Starconn																																																																																																																																																																																																																				
Connector Model Number	089H133-000100-G2-R, compatible with MSA-98375-33Y902 & ELCO 08-8210-033-340-800 ¹⁾																																																																																																																																																																																																																				
Pin#	Symbol	Pin#	Symbol	Pin#	Symbol																																																																																																																																																																																																																
1	GND	12	GND	23	B3																																																																																																																																																																																																																
2	DOTCLK	13	G0	24	B4																																																																																																																																																																																																																
3	NC	14	G1	25	B5																																																																																																																																																																																																																
4	NC	15	G2	26	GND																																																																																																																																																																																																																
5	GND	16	G3	27	DE																																																																																																																																																																																																																
6	R0	17	G4	28	VDD																																																																																																																																																																																																																
7	R1	18	G5	29	VDD																																																																																																																																																																																																																
8	R2	19	GND	30	RL																																																																																																																																																																																																																
9	R3	20	B0	31	UD																																																																																																																																																																																																																
10	R4	21	B1	32	NC																																																																																																																																																																																																																
11	R5	22	B2	33	GND																																																																																																																																																																																																																
Manufacturer ¹⁾	Starconn ¹⁾																																																																																																																																																																																																																				
Connector Model Number ¹⁾	089H133-000100-G2-R, compatible with MSA-98375-33Y902 & ELCO 08-8210-033-340-800 ¹⁾																																																																																																																																																																																																																				
	19	7.2 LED Backlight Unit (CN2): Backlight Connector	Change CN2 type Delete Pin define, it was shown on section 6.6																																																																																																																																																																																																																		
		<table border="1"> <tr> <td>Manufacturer</td> <td>JST</td> </tr> <tr> <td>Connector Model Number</td> <td>SM05B-SRKS-G-TB compatible with JST SM05B-SRSS-TB (LS) (SN)</td> </tr> <tr> <td>Mating Connector Model Number</td> <td>JST SHR-06V-BKH-F-B or compatible</td> </tr> </table> <table border="1"> <thead> <tr> <th>Pin #</th> <th>Symbol</th> <th>Pin #</th> <th>Symbol</th> </tr> </thead> <tbody> <tr><td>1</td><td>V_{LED}</td><td>4</td><td>GND</td></tr> <tr><td>2</td><td>V_{LED}</td><td>5</td><td>PWM DIM</td></tr> <tr><td>3</td><td>GND</td><td>6</td><td>LED ON/OFF</td></tr> </tbody> </table>	Manufacturer	JST	Connector Model Number	SM05B-SRKS-G-TB compatible with JST SM05B-SRSS-TB (LS) (SN)	Mating Connector Model Number	JST SHR-06V-BKH-F-B or compatible	Pin #	Symbol	Pin #	Symbol	1	V _{LED}	4	GND	2	V _{LED}	5	PWM DIM	3	GND	6	LED ON/OFF	<table border="1"> <tr> <td>Manufacturer¹⁾</td> <td>STM or compatible¹⁾</td> </tr> <tr> <td>Connector Model Number (male)¹⁾</td> <td>P24021P6 or compatible¹⁾</td> </tr> <tr> <td>Mating Connector Model Number (female)¹⁾</td> <td>STM / MASN1.0005N06 or compatible¹⁾</td> </tr> </table>	Manufacturer ¹⁾	STM or compatible ¹⁾	Connector Model Number (male) ¹⁾	P24021P6 or compatible ¹⁾	Mating Connector Model Number (female) ¹⁾	STM / MASN1.0005N06 or compatible ¹⁾																																																																																																																																																																																						
Manufacturer	JST																																																																																																																																																																																																																				
Connector Model Number	SM05B-SRKS-G-TB compatible with JST SM05B-SRSS-TB (LS) (SN)																																																																																																																																																																																																																				
Mating Connector Model Number	JST SHR-06V-BKH-F-B or compatible																																																																																																																																																																																																																				
Pin #	Symbol	Pin #	Symbol																																																																																																																																																																																																																		
1	V _{LED}	4	GND																																																																																																																																																																																																																		
2	V _{LED}	5	PWM DIM																																																																																																																																																																																																																		
3	GND	6	LED ON/OFF																																																																																																																																																																																																																		
Manufacturer ¹⁾	STM or compatible ¹⁾																																																																																																																																																																																																																				
Connector Model Number (male) ¹⁾	P24021P6 or compatible ¹⁾																																																																																																																																																																																																																				
Mating Connector Model Number (female) ¹⁾	STM / MASN1.0005N06 or compatible ¹⁾																																																																																																																																																																																																																				
		7.3 LED Light Bar Input (CN3): Light Bar Connector ¹⁾																																																																																																																																																																																																																			

	19	<p>7.3 LED Light Bar Input (CN3): Light Bar Connector</p> <table border="1"> <tr> <td>Manufacturer</td> <td>STM or compatible</td> </tr> <tr> <td>Connector Model Number</td> <td>P24021P6 or compatible</td> </tr> <tr> <td>Mating Connector Model Number</td> <td>SM06B-SHLS-TF or compatible</td> </tr> </table> <table border="1"> <thead> <tr> <th>Pin #</th> <th>Symbol</th> <th>Pin Description</th> <th>Cable color</th> </tr> </thead> <tbody> <tr> <td>1</td> <td>AN1</td> <td>Channel 1 LED anode</td> <td>Red</td> </tr> <tr> <td>2</td> <td>AN2</td> <td>Channel 2 LED anode</td> <td>Red</td> </tr> <tr> <td>3</td> <td>AN3</td> <td>Channel 3 LED anode</td> <td>Red</td> </tr> <tr> <td>4</td> <td>CA1</td> <td>Channel 1 LED cathode</td> <td>White</td> </tr> <tr> <td>5</td> <td>CA2</td> <td>Channel 2 LED cathode</td> <td>Blue</td> </tr> <tr> <td>6</td> <td>CA3</td> <td>Channel 3 LED cathode</td> <td>Black</td> </tr> </tbody> </table>	Manufacturer	STM or compatible	Connector Model Number	P24021P6 or compatible	Mating Connector Model Number	SM06B-SHLS-TF or compatible	Pin #	Symbol	Pin Description	Cable color	1	AN1	Channel 1 LED anode	Red	2	AN2	Channel 2 LED anode	Red	3	AN3	Channel 3 LED anode	Red	4	CA1	Channel 1 LED cathode	White	5	CA2	Channel 2 LED cathode	Blue	6	CA3	Channel 3 LED cathode	Black	<p>Add LED light bar connector information, reduce light bar cable Q'ty</p> <p>7.3 LED Light Bar Input (CN3): Light Bar Connector</p> <table border="1"> <tr> <td>Manufacturer</td> <td>STM or compatible</td> </tr> <tr> <td>Connector Model Number (male)</td> <td>P24021P6 or compatible</td> </tr> <tr> <td>Mating Connector Model Number (female)</td> <td>JST / SM06B-SHLK-GTF(HF) or compatible</td> </tr> </table> <table border="1"> <thead> <tr> <th>Pin #</th> <th>Symbol</th> <th>Pin Description</th> <th>Cable color</th> </tr> </thead> <tbody> <tr> <td>1</td> <td>NC</td> <td></td> <td></td> </tr> <tr> <td>2</td> <td>NC</td> <td></td> <td></td> </tr> <tr> <td>3</td> <td>AN1</td> <td>Channel 1 LED anode</td> <td>Red</td> </tr> <tr> <td>4</td> <td>CA1</td> <td>Channel 1 LED cathode</td> <td>White</td> </tr> <tr> <td>5</td> <td>NC</td> <td></td> <td></td> </tr> <tr> <td>6</td> <td>NC</td> <td></td> <td></td> </tr> </tbody> </table>	Manufacturer	STM or compatible	Connector Model Number (male)	P24021P6 or compatible	Mating Connector Model Number (female)	JST / SM06B-SHLK-GTF(HF) or compatible	Pin #	Symbol	Pin Description	Cable color	1	NC			2	NC			3	AN1	Channel 1 LED anode	Red	4	CA1	Channel 1 LED cathode	White	5	NC			6	NC		
Manufacturer	STM or compatible																																																																						
Connector Model Number	P24021P6 or compatible																																																																						
Mating Connector Model Number	SM06B-SHLS-TF or compatible																																																																						
Pin #	Symbol	Pin Description	Cable color																																																																				
1	AN1	Channel 1 LED anode	Red																																																																				
2	AN2	Channel 2 LED anode	Red																																																																				
3	AN3	Channel 3 LED anode	Red																																																																				
4	CA1	Channel 1 LED cathode	White																																																																				
5	CA2	Channel 2 LED cathode	Blue																																																																				
6	CA3	Channel 3 LED cathode	Black																																																																				
Manufacturer	STM or compatible																																																																						
Connector Model Number (male)	P24021P6 or compatible																																																																						
Mating Connector Model Number (female)	JST / SM06B-SHLK-GTF(HF) or compatible																																																																						
Pin #	Symbol	Pin Description	Cable color																																																																				
1	NC																																																																						
2	NC																																																																						
3	AN1	Channel 1 LED anode	Red																																																																				
4	CA1	Channel 1 LED cathode	White																																																																				
5	NC																																																																						
6	NC																																																																						
	21	<p>7.4 PIN 1 definition of CN1 and CN2</p> 	<p>Add CN3 mark</p> <p>7.4 PIN 1 definition of CN1 and CN2</p> 																																																																				
	21	<p>7.5 PIN 1 definition of CN3</p> 	<p>Add CN3 mark</p> <p>7.5 PIN 1 definition of CN3</p> 																																																																				
	23	<p>NOTE: 1.CN1:I/F CONNECTOR IS 089H33-000100-G2-R (STARCONN) CN2:LED DRIVER CONNECTOR IS SM06B-SRKHFS(LF)(SNXJST) 2.TOLERANCE IS ±0.5 IF NOT SPECIFIED.</p>	<p>Update Drawing X1 and change CN2 type</p> <p>NOTE: 1.CN1:I/F CONNECTOR IS 089H33-000100-G2-R (STARCONN) CN2:LED DRIVER CONNECTOR IS C1106MIHRO-NH (CviLux) ⚠ 2.TOLERANCE IS ±0.5 IF NOT SPECIFIED.</p>																																																																				
	24	<p>10.1 Shipping Label (on the rear side of TFT-LCD display)</p> 	<p>10.1 Shipping Label (on the rear side of TFT-LCD display)</p> 																																																																				
	25	<p>11.4 National Test Lab Requirement The TFT-LCD Module will satisfy all requirements for compliance to UL 60950 (U.S.A. Information Technology Equipment)</p>	<p>11.4 National Test Lab Requirement The display module will satisfy all requirements for compliance to: IEC/UL 62368-1</p>																																																																				
0.2 2024/11/05	7	<p>Typical Power Consumption</p> <table border="1"> <tr> <td>Watt</td> <td>2.21W (LCD: 0.09W / LED BLU: 2.12W) @ All white pattern, Full Load and VLED=12V</td> </tr> </table>	Watt	2.21W (LCD: 0.09W / LED BLU: 2.12W) @ All white pattern, Full Load and VLED=12V	<p>Lower the power consumption</p> <table border="1"> <tr> <td>Watt</td> <td>1.6W (LCD: 0.09W / LED BLU: 1.51W) @ All white pattern, Full Load and VLED=12V</td> </tr> </table>	Watt	1.6W (LCD: 0.09W / LED BLU: 1.51W) @ All white pattern, Full Load and VLED=12V																																																																
Watt	2.21W (LCD: 0.09W / LED BLU: 2.12W) @ All white pattern, Full Load and VLED=12V																																																																						
Watt	1.6W (LCD: 0.09W / LED BLU: 1.51W) @ All white pattern, Full Load and VLED=12V																																																																						

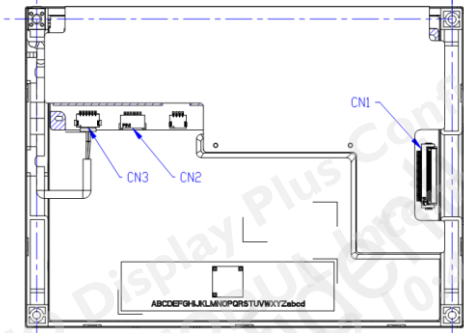
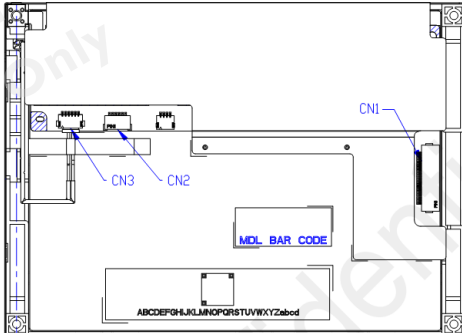
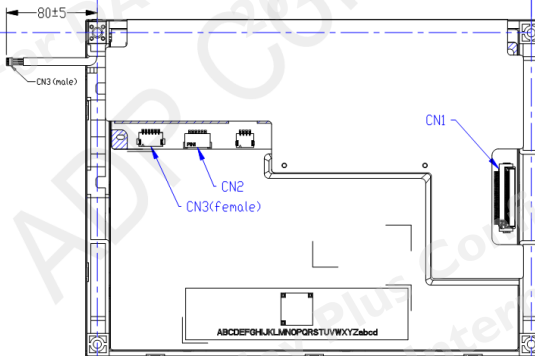
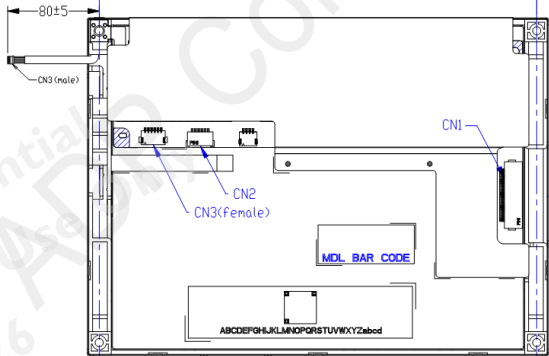
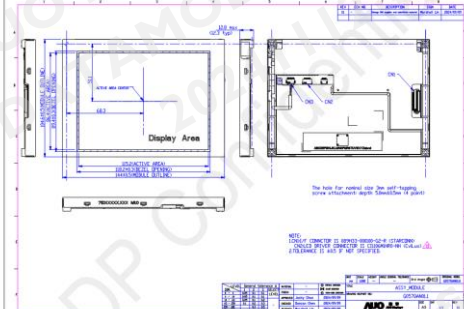
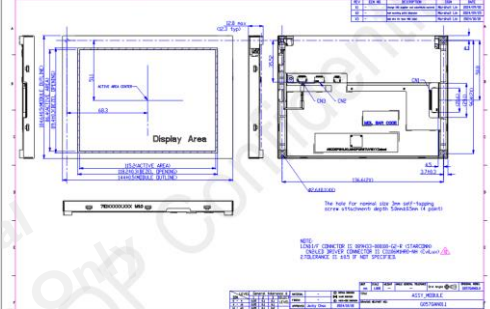
14	<p>5.2 Backlight Unit Driving 5.2.1 Parameter guideline for LED Following characteristics are measured under stable condition at 25°C (Room Temperature).</p> <table border="1"> <thead> <tr> <th>Symbol</th> <th>Parameter</th> <th>Min</th> <th>Typ</th> <th>Max</th> <th>Units</th> <th>Remark</th> </tr> </thead> <tbody> <tr> <td>V_{LED}</td> <td>Input Voltage</td> <td>9</td> <td>12</td> <td>20</td> <td>Volt</td> <td></td> </tr> <tr> <td>I_{LED}</td> <td>Input Current</td> <td>-</td> <td>0.15</td> <td>0.16</td> <td>A</td> <td>$V_{LED}=12V, D_{PWM}=100\%$</td> </tr> <tr> <td>$P_{LED}$</td> <td>Power Consumption</td> <td>-</td> <td>2.12</td> <td>2.23</td> <td>W</td> <td>$V_{LED}=12V, D_{PWM}=100\%$</td> </tr> <tr> <td>$I_{rushLED}$</td> <td>Inrush Current</td> <td>-</td> <td>-</td> <td>1.5</td> <td>A</td> <td>$V_{LED}=12V, D_{PWM}=100\%$</td> </tr> <tr> <td>$V_{PWM DIM}$</td> <td>Dimming control Voltage High</td> <td>2.0</td> <td>3.3</td> <td>5</td> <td>Volt</td> <td rowspan="2">Note 1, 2</td> </tr> <tr> <td></td> <td>Dimming control Voltage Low</td> <td>-</td> <td>-</td> <td>0.15</td> <td>Volt</td> </tr> <tr> <td>F_{PWM}</td> <td>Dimming Frequency</td> <td>200</td> <td>-</td> <td>25K</td> <td>Hz</td> <td rowspan="2">Note 3, 4</td> </tr> <tr> <td>D_{PWM}</td> <td>Dimming duty cycle</td> <td>1</td> <td>-</td> <td>100</td> <td>%</td> </tr> <tr> <td>$V_{LED On/Off}$</td> <td>On Control Voltage</td> <td>2</td> <td>3.3</td> <td>5</td> <td>Volt</td> <td rowspan="2">Note 3, 4</td> </tr> <tr> <td></td> <td>Off Control Voltage</td> <td>-</td> <td>-</td> <td>0.6</td> <td>Volt</td> </tr> <tr> <td>I_f</td> <td>LED Forward Current</td> <td>-</td> <td>80</td> <td>-</td> <td>mA</td> <td>$T_a = 25^{\circ}C$</td> </tr> <tr> <td>V_f</td> <td>LED Forward Voltage</td> <td>22.4</td> <td>23.6</td> <td>24.8</td> <td>Volt</td> <td>$I_f = 80mA, T_a = 25^{\circ}C$</td> </tr> <tr> <td>Operating Life</td> <td></td> <td>50,000</td> <td>-</td> <td>-</td> <td>Hrs</td> <td>Note 5, 6, 7</td> </tr> </tbody> </table>	Symbol	Parameter	Min	Typ	Max	Units	Remark	V_{LED}	Input Voltage	9	12	20	Volt		I_{LED}	Input Current	-	0.15	0.16	A	$V_{LED}=12V, D_{PWM}=100\%$	P_{LED}	Power Consumption	-	2.12	2.23	W	$V_{LED}=12V, D_{PWM}=100\%$	$I_{rushLED}$	Inrush Current	-	-	1.5	A	$V_{LED}=12V, D_{PWM}=100\%$	$V_{PWM DIM}$	Dimming control Voltage High	2.0	3.3	5	Volt	Note 1, 2		Dimming control Voltage Low	-	-	0.15	Volt	F_{PWM}	Dimming Frequency	200	-	25K	Hz	Note 3, 4	D_{PWM}	Dimming duty cycle	1	-	100	%	$V_{LED On/Off}$	On Control Voltage	2	3.3	5	Volt	Note 3, 4		Off Control Voltage	-	-	0.6	Volt	I_f	LED Forward Current	-	80	-	mA	$T_a = 25^{\circ}C$	V_f	LED Forward Voltage	22.4	23.6	24.8	Volt	$I_f = 80mA, T_a = 25^{\circ}C$	Operating Life		50,000	-	-	Hrs	Note 5, 6, 7	<p>Lower the current 5.2 Backlight Unit Driving 5.2.1 Parameter guideline for LED Following characteristics are measured under stable condition at 25°C (Room Temperature).</p> <table border="1"> <thead> <tr> <th>Symbol</th> <th>Parameter</th> <th>Min</th> <th>Typ</th> <th>Max</th> <th>Units</th> <th>Remark</th> </tr> </thead> <tbody> <tr> <td>V_{LED}</td> <td>Input Voltage</td> <td>9</td> <td>12</td> <td>20</td> <td>Volt</td> <td></td> </tr> <tr> <td>I_{LED}</td> <td>Input Current</td> <td>-</td> <td>0.126</td> <td>0.132</td> <td>A</td> <td>$V_{LED}=12V, D_{PWM}=100\%$</td> </tr> <tr> <td>$P_{LED}$</td> <td>Power Consumption</td> <td>-</td> <td>1.51</td> <td>1.59</td> <td>W</td> <td>$V_{LED}=12V, D_{PWM}=100\%$</td> </tr> <tr> <td>$I_{rushLED}$</td> <td>Inrush Current</td> <td>-</td> <td>-</td> <td>1.5</td> <td>A</td> <td>$V_{LED}=12V, D_{PWM}=100\%$</td> </tr> <tr> <td>$V_{PWM DIM}$</td> <td>Dimming control Voltage High</td> <td>2.0</td> <td>3.3</td> <td>5</td> <td>Volt</td> <td rowspan="2">Note 1, 2</td> </tr> <tr> <td></td> <td>Dimming control Voltage Low</td> <td>-</td> <td>-</td> <td>0.15</td> <td>Volt</td> </tr> <tr> <td>F_{PWM}</td> <td>Dimming Frequency</td> <td>200</td> <td>-</td> <td>25K</td> <td>Hz</td> <td rowspan="2">Note 3, 4</td> </tr> <tr> <td>D_{PWM}</td> <td>Dimming duty cycle</td> <td>1</td> <td>-</td> <td>100</td> <td>%</td> </tr> <tr> <td>$V_{LED On/Off}$</td> <td>On Control Voltage</td> <td>2</td> <td>3.3</td> <td>5</td> <td>Volt</td> <td rowspan="2">Note 3, 4</td> </tr> <tr> <td></td> <td>Off Control Voltage</td> <td>-</td> <td>-</td> <td>0.6</td> <td>Volt</td> </tr> <tr> <td>I_f</td> <td>LED Forward Current</td> <td>-</td> <td>57</td> <td>-</td> <td>mA</td> <td>$T_a = 25^{\circ}C$</td> </tr> <tr> <td>V_f</td> <td>LED Forward Voltage</td> <td>22.4</td> <td>23.6</td> <td>24.8</td> <td>Volt</td> <td>$I_f = 57mA, T_a = 25^{\circ}C$</td> </tr> <tr> <td>Operating Life</td> <td></td> <td>50,000</td> <td>-</td> <td>-</td> <td>Hrs</td> <td>Note 5, 6, 7</td> </tr> </tbody> </table>	Symbol	Parameter	Min	Typ	Max	Units	Remark	V_{LED}	Input Voltage	9	12	20	Volt		I_{LED}	Input Current	-	0.126	0.132	A	$V_{LED}=12V, D_{PWM}=100\%$	P_{LED}	Power Consumption	-	1.51	1.59	W	$V_{LED}=12V, D_{PWM}=100\%$	$I_{rushLED}$	Inrush Current	-	-	1.5	A	$V_{LED}=12V, D_{PWM}=100\%$	$V_{PWM DIM}$	Dimming control Voltage High	2.0	3.3	5	Volt	Note 1, 2		Dimming control Voltage Low	-	-	0.15	Volt	F_{PWM}	Dimming Frequency	200	-	25K	Hz	Note 3, 4	D_{PWM}	Dimming duty cycle	1	-	100	%	$V_{LED On/Off}$	On Control Voltage	2	3.3	5	Volt	Note 3, 4		Off Control Voltage	-	-	0.6	Volt	I_f	LED Forward Current	-	57	-	mA	$T_a = 25^{\circ}C$	V_f	LED Forward Voltage	22.4	23.6	24.8	Volt	$I_f = 57mA, T_a = 25^{\circ}C$	Operating Life		50,000	-	-	Hrs	Note 5, 6, 7
Symbol	Parameter	Min	Typ	Max	Units	Remark																																																																																																																																																																																										
V_{LED}	Input Voltage	9	12	20	Volt																																																																																																																																																																																											
I_{LED}	Input Current	-	0.15	0.16	A	$V_{LED}=12V, D_{PWM}=100\%$																																																																																																																																																																																										
P_{LED}	Power Consumption	-	2.12	2.23	W	$V_{LED}=12V, D_{PWM}=100\%$																																																																																																																																																																																										
$I_{rushLED}$	Inrush Current	-	-	1.5	A	$V_{LED}=12V, D_{PWM}=100\%$																																																																																																																																																																																										
$V_{PWM DIM}$	Dimming control Voltage High	2.0	3.3	5	Volt	Note 1, 2																																																																																																																																																																																										
	Dimming control Voltage Low	-	-	0.15	Volt																																																																																																																																																																																											
F_{PWM}	Dimming Frequency	200	-	25K	Hz	Note 3, 4																																																																																																																																																																																										
D_{PWM}	Dimming duty cycle	1	-	100	%																																																																																																																																																																																											
$V_{LED On/Off}$	On Control Voltage	2	3.3	5	Volt	Note 3, 4																																																																																																																																																																																										
	Off Control Voltage	-	-	0.6	Volt																																																																																																																																																																																											
I_f	LED Forward Current	-	80	-	mA	$T_a = 25^{\circ}C$																																																																																																																																																																																										
V_f	LED Forward Voltage	22.4	23.6	24.8	Volt	$I_f = 80mA, T_a = 25^{\circ}C$																																																																																																																																																																																										
Operating Life		50,000	-	-	Hrs	Note 5, 6, 7																																																																																																																																																																																										
Symbol	Parameter	Min	Typ	Max	Units	Remark																																																																																																																																																																																										
V_{LED}	Input Voltage	9	12	20	Volt																																																																																																																																																																																											
I_{LED}	Input Current	-	0.126	0.132	A	$V_{LED}=12V, D_{PWM}=100\%$																																																																																																																																																																																										
P_{LED}	Power Consumption	-	1.51	1.59	W	$V_{LED}=12V, D_{PWM}=100\%$																																																																																																																																																																																										
$I_{rushLED}$	Inrush Current	-	-	1.5	A	$V_{LED}=12V, D_{PWM}=100\%$																																																																																																																																																																																										
$V_{PWM DIM}$	Dimming control Voltage High	2.0	3.3	5	Volt	Note 1, 2																																																																																																																																																																																										
	Dimming control Voltage Low	-	-	0.15	Volt																																																																																																																																																																																											
F_{PWM}	Dimming Frequency	200	-	25K	Hz	Note 3, 4																																																																																																																																																																																										
D_{PWM}	Dimming duty cycle	1	-	100	%																																																																																																																																																																																											
$V_{LED On/Off}$	On Control Voltage	2	3.3	5	Volt	Note 3, 4																																																																																																																																																																																										
	Off Control Voltage	-	-	0.6	Volt																																																																																																																																																																																											
I_f	LED Forward Current	-	57	-	mA	$T_a = 25^{\circ}C$																																																																																																																																																																																										
V_f	LED Forward Voltage	22.4	23.6	24.8	Volt	$I_f = 57mA, T_a = 25^{\circ}C$																																																																																																																																																																																										
Operating Life		50,000	-	-	Hrs	Note 5, 6, 7																																																																																																																																																																																										
22	<p>7.4 PIN 1 definition of CN1 and CN2</p>  <p>(Rear side of TFT-LCD)</p>	<p>7.4 PIN 1 definition of CN1 and CN2</p>  <p>(Rear side of TFT-LCD)</p>																																																																																																																																																																																														
22	<p>7.5 PIN 1 definition of CN3</p>  <p>(Rear side of TFT-LCD)</p>	<p>7.5 PIN 1 definition of CN3</p>  <p>(Rear side of TFT-LCD)</p>																																																																																																																																																																																														
24	<p>9. Mechanical Characteristics</p>  <p>Display Area</p>	<p>9. Mechanical Characteristics</p>  <p>Display Area</p>																																																																																																																																																																																														

1. Operating Precautions

- 1) Display area (Polarizer) of TFT-LCD Module is easily to be damaged, please be cautious and not to scratch it.
- 2) Be sure to power off your machine before connecting or disconnecting your signal cable to TFT-LCD Module.
- 3) Wipe off water drop on display area immediately. Long contact with water may cause discoloration or spots.
- 4) When the panel surface is soiled, wipe it with absorbent cotton or soft cloth.
- 5) Display area (Glass) of TFT-LCD Module may be broken or cracked if bump Module against hard object.
- 6) To avoid ESD (Electro Static Discharge) damage, be sure to ground yourself before handling TFT-LCD Module.
- 7) Do not open nor modify the TFT-LCD module assembly.
- 8) Do not press the reflector sheet at the back of the module to any direction.
- 9) In case if TFT-LCD module has to be put back into the packing container slot after it was taken out from the container, do not press the center of the LED Reflector edge. Instead, press at the far ends of the LED Reflector edge softly. Otherwise the TFT-LCD Module may be damaged.
- 10) When inserting or removing of your signal cable to TFT-LCD Module, be sure not to apply abnormal force (rotate, tilt...etc.) to the Connector of the TFT-LCD Module.
- 11) TFT-LCD Module is not allowed to be twisted & bent even force is added on module in a very short time. Please design your display product well to avoid external force applying to module by end-user directly.
- 12) Small amount of materials without flammability grade are used in the TFT-LCD module. The TFT-LCD module should be supplied by power complied with requirements of Limited Power Source (IEC60950 or UL1950), or be applied exemption.
- 13) Severe temperature condition may result in different luminance, response time.
- 14) Continuous operating TFT-LCD Module under high temperature environment may accelerate LED light bar exhaustion and reduce luminance dramatically.
- 15) The data on this specification sheet is applicable when TFT-LCD module is placed in landscape position.
- 16) Continuous displaying fixed pattern may induce image sticking. It's recommended to use screen saver or moving content periodically if fixed pattern is displayed on the screen.

2. General Description

G057QAN01.1 is designed for industrial display applications with QVGA (320 x RGB x 240) resolution and 262k colors (RGB 6-bits). It is composed of a TFT-LCD panel, driver ICs, control and power supply circuits board and backlight unit including LED driver circuit. G057QAN01.1 offers CMOS interface for display signal input.

2.1 Display Characteristics

The following items are G057QAN01.1 characteristics summary at 25 °C(Room Temperature).

Items	Unit	Specifications
Screen Diagonal	inch	5.7
Active Area	mm	115.2(H) x 86.4(V)
Pixels H x V		320 x 3(RGB) x 240
Pixel Pitch	mm	0.36 x 0.36
Pixel Arrangement		R.G.B. Vertical Stripe
Display Mode		AHVA mode, Normally Black
Nominal Input Voltage VDD	Volt	3.3 typ.
Typical Power Consumption	Watt	1.6W (LCD: 0.09W / LED BLU: 1.51W) @ All white pattern, Full Load and VLED=12V
Weight	Grams	150g (typ.), 165g (max.)
Physical Size	mm	144.0(H)x 104.6(V) x 12.3(D) (typ.)
Electrical Interface		CMOS 6-bit Parallel RGB
Surface Treatment		Anti-Glare, Hardness 3H
Support Color		262K colors
The most suitable view angle		12 o'clock
Temperature Range		
Operating	°C	-30 to +85
Storage (Non-Operating)	°C	-30 to +85
RoHS Compliance		RoHS Compliance

2.2 Optical Characteristics

The optical characteristics are measured under stable conditions at 25°C (Room Temperature).

Item	Unit	Conditions	Min.	Typ.	Max.	Remark
White Luminance	cd/m ²	V _{LED} = 12V, D _{PWM} = 100% (center point)	600	800	-	Note 1
Uniformity	%	5 Points		-	1.3	Note 1, 2, 3
Contrast Ratio			700	1000	-	Note 4
Response Time	msec	Rising	-	15	20	Note 5
	msec	Falling	-	10	15	
	msec	Rising + Falling	-	25	35	
Viewing Angle	degree	Horizontal (Right)	80	89	-	Note 6
	degree	Horizontal (Left)	80	89	-	
	degree	Vertical (Upper)	80	89	-	
	degree	Vertical (Lower)	80	89	-	
Color / Chromaticity Coordinates (CIE 1931)		White x	0.263	0.313	0.363	
		White y	0.279	0.329	0.379	
		Red x		TBD		
		Red y		TBD		
		Green x		TBD		
		Green y		TBD		
		Blue x		TBD		
		Blue y		TBD		
Color Gamut	%		-	50	-	

Note 1: Measurement method

Equipment Pattern Generator, Power Supply, Digital Voltmeter, Luminance meter (SR_3 or equivalent)

Aperture 1° with 50cm viewing distance

Test Point Center

Environment < 1 lux

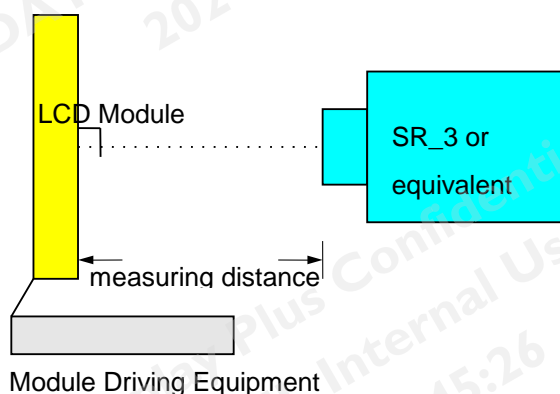

Note 2: Definition of 5 points position (Display active area: 115.2mm(W) x 86.4mm(H))

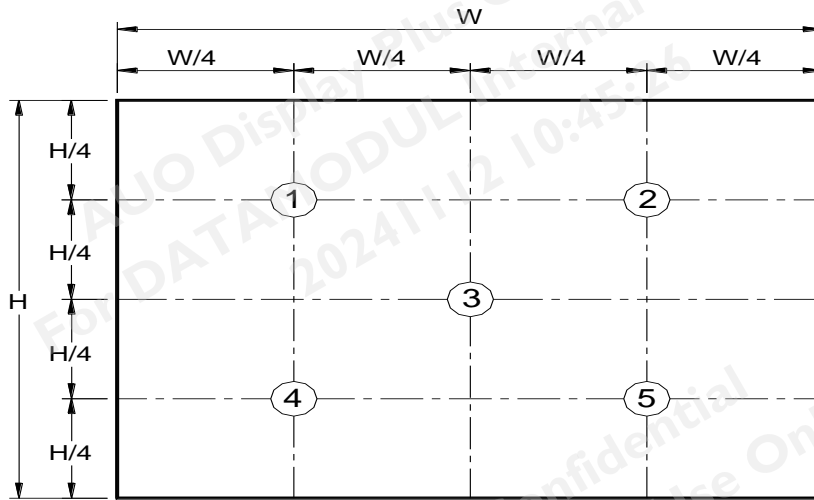

Note 3:

The luminance uniformity of 5 points is defined by dividing the minimum luminance values by the maximum test point luminance

$$\text{Uniformity (5 points)} = \frac{\text{Minimum Luminance of 5 points}}{\text{Maximum Luminance of 5 points}}$$

Note 4: Definition of contrast ratio (CR):

$$\text{Contrast ratio (CR)} = \frac{\text{Brightness @ "White" state}}{\text{Brightness @ "Black" state}}$$

Note 5: Definition of response time:

The output signals of photo detector are measured when the input signals are changed from "White" to "Black" (falling time) and from "Black" to "White" (rising time), respectively. The response time interval definition is between 10% and 90% of amplitude. Please refer to the figure as below.

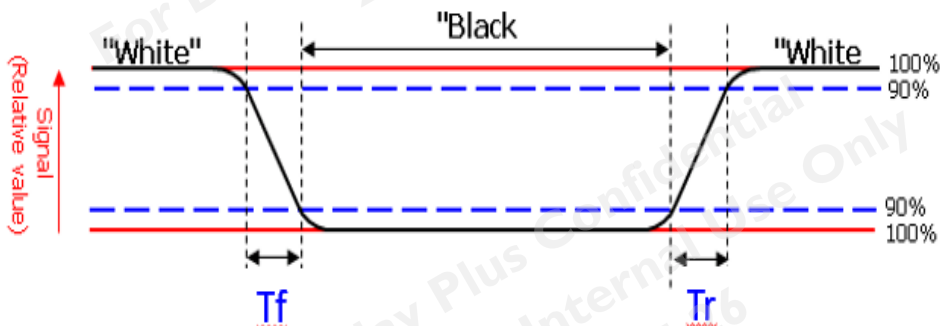

Note 6: Definition of viewing angle

Viewing angle is the measurement of contrast ratio ≥ 10 , at the screen center, over 180° horizontal and 180° vertical range. The 180° horizontal (θ_L , θ_R) and 180° vertical (ϕ_H , ϕ_L) range are illustrated as following figure.

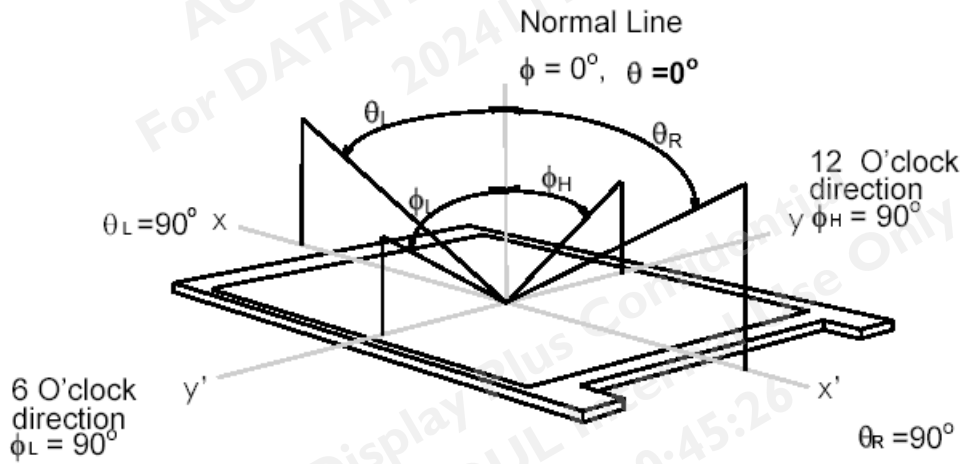

3. Functional Block Diagram

The following diagram shows the functional block of the G057QAN01.1 color TFT/LCD module.

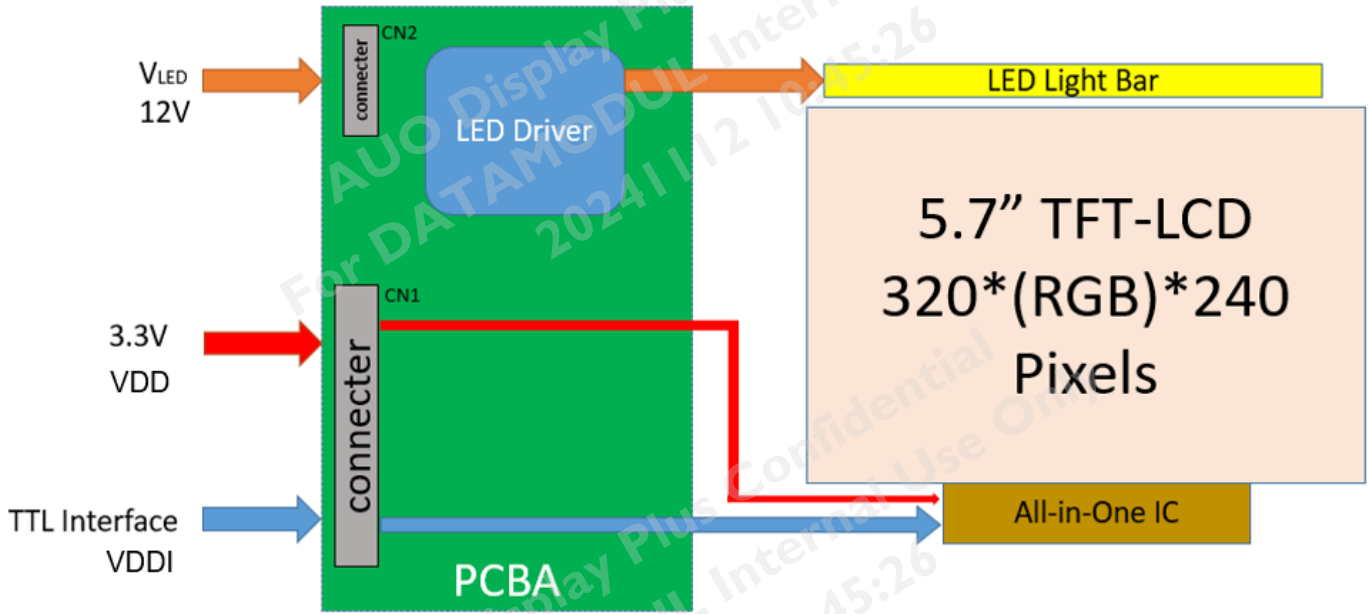

4. Absolute Maximum Ratings

4.1 Absolute Ratings of TFT LCD

Item	Symbol	Min	Max	Unit	Remark
Logic/LCD Drive Voltage	VDD	-0.3	+4.0	Volt	Ta= 25°C
LCD Input Signal Voltage	VIN	-0.3	+4.0	Volt	Ta= 25°C
LED BLU Drive Voltage	V _{LED}	-0.3	+26.5	Volt	Ta= 25°C
LED Dimming Input Voltage	V _{PWM}	-0.3	+26.5	Volt	Ta= 25°C
LED On/Off Input Voltage	V _{LED On/Off}	-0.3	+26.5	Volt	Ta= 25°C

4.2 Absolute Ratings of Environment

Item	Symbol	Min	Max	Unit	Remark
Operating Temperature	TOP	-30	+85	°C	Note 1, 2
Operation Humidity	HOP	5	95	%RH	Note 1, 2
Storage Temperature	TST	-30	+85	°C	Note 1
Storage Humidity	HST	5	95	%RH	Note 1

Note 1: Maximum Wet-Bulb should be 39°C and no condensation.

Note 2: Only operation is guaranteed. Optical performance should be evaluated at 25°C only.

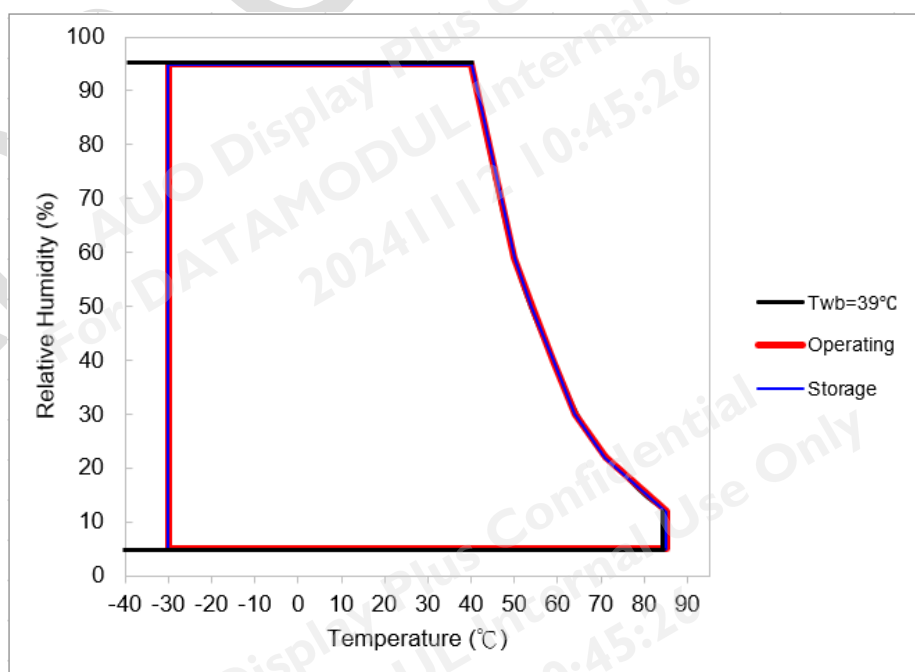

5. Electrical Characteristics

5.1 TFT-LCD Driving

5.1.1 Power Specification

Symbol	Parameter	Min	Typ	Max	Units	Remark
VDD	Logic/LCD Drive Voltage	3.0	3.3	3.6	[Volt]	
VDDI	LCD Input Signal Voltage	3.0	3.3	3.6	[Volt]	
IDD	VDD Current	-	27	30	[mA]	All White Pattern (VDD=3.3V, at 60Hz)
Irush	LCD Inrush Current	-	-	280	[A]	Note 1
PDD	VDD Power		0.09	0.1	[Watt]	All White Pattern (VDD=3.3V, at 60Hz)
VDDrp	Allowable Logic/LCD Drive Ripple Voltage	-	-	100	mVp-p	All White Pattern (VDD=3.3V, at 60Hz)

Note 1: Measurement condition:

VDD

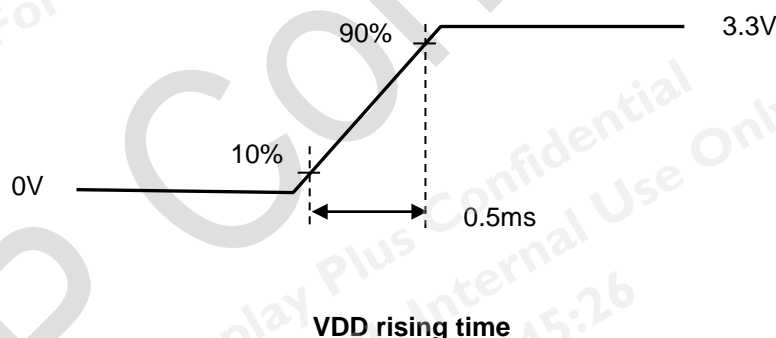

5.1.2 Signal Electrical Characteristics

Input signals shall be low or Hi-Z state when VDD is off.

Parameter		Symbol	Min.	Typ.	Max.	Unit	Remarks
Logic Input Voltage for Display Signals	High	VIH	0.7VDD	-	VDD	Volt	
	Low	VIL	0	-	0.3VDD	Volt	
Input Voltage for RL/UD	High	VIH	0.7VDD	-	VDD	Volt	
	Low	VIL	0	-	0.2VDD	Volt	

5.2 Backlight Unit Driving

5.2.1 Parameter guideline for LED

Following characteristics are measured under stable condition at 25°C (Room Temperature).

Symbol	Parameter	Min	Typ	Max	Units	Remark
V _{LED}	Input Voltage	9	12	20	Volt	
I _{LED}	Input Current	-	0.126	0.132	A	V _{LED} =12V, D _{PWM} =100%
P _{LED}	Power Consumption	-	1.51	1.59	W	V _{LED} =12V, D _{PWM} =100%
I _{rushLED}	Inrush Current	-		1.5	A	V _{LED} =12V, D _{PWM} =100%
V _{PWM DIM}	Dimming control Voltage High	2.0	3.3	5	Volt	Note 1,2
	Dimming control Voltage Low	-	-	0.15	Volt	
F _{PWM}	Dimming Frequency	200		25K	Hz	
D _{PWM}	Dimming duty cycle	1		100	%	
V _{LED On/Off}	On Control Voltage	2	3.3	5	Volt	Note 3, 4
	Off Control Voltage	-	-	0.6	Volt	
I _F	LED Forward Current		57		mA	Ta = 25oC
V _F	LED Forward Voltage	22.4	23.6	24.8	Volt	IF = 57mA, Ta = 25°C
Operating Life		50,000	-	-	Hrs	Note 5, 6, 7

Note 1: PWM dimming function can be operated by PWM signal. PWM duty cycle can adjust white Luminance.

(PWM High: ON and PWM Low: OFF)

Note 2: PWM signal can not be floating and pull-down to ground when waiting.

Note 3: Enable (V_{LED On/Off}) must be turned on late than V_{LED} and PWM Signal.

Note 4: Enable (V_{LED On/Off}) must be turned off early than V_{LED} and PWM Signal.

Note 5: If G057QAN01.1 module is driven by high current or at high ambient temperature & humidity condition. The operating life will be reduced.

Note 6: Operating life means brightness goes down to 50% initial brightness. Minimum operating life time is estimated data.

Note 7: The test condition is 80mA in 25°C room temperature

Note 8: See Section 6.6 for LED Backlight Unit Interface Signal Description

6. Signal Characteristic

6.1 Pixel Format Image

Following figure shows the relationship between input signal and LCD pixel format.

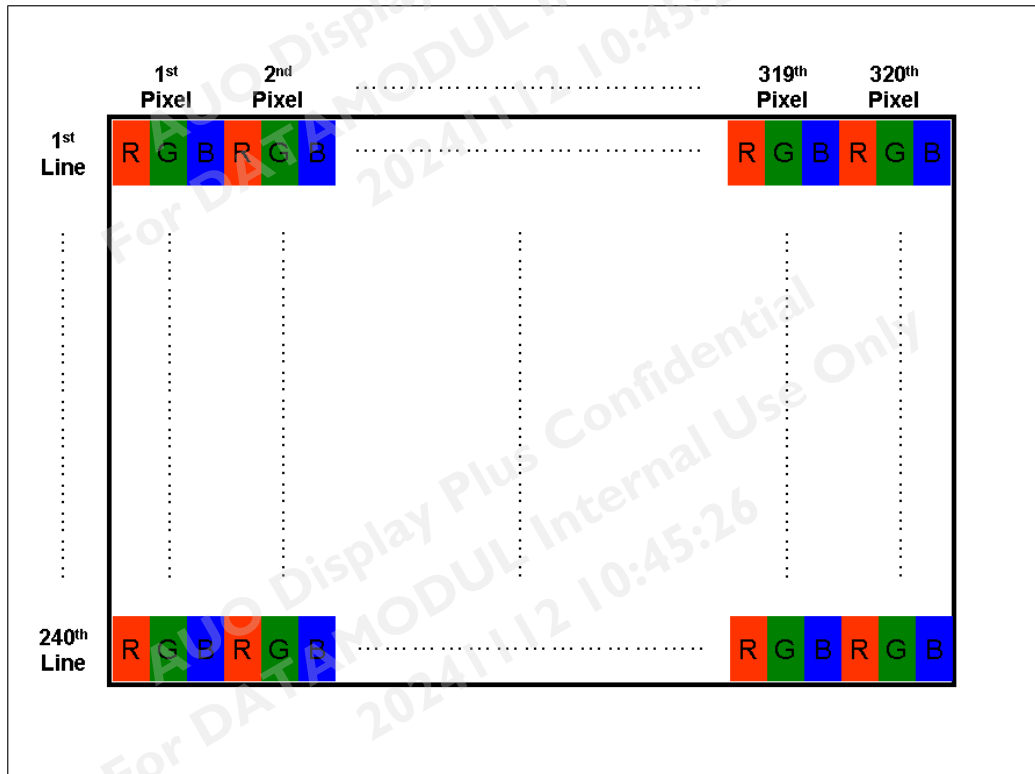

6.2 Scanning Direction

The following figures show the image seen from the front view. The arrow indicates the direction of scan.

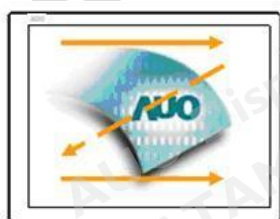

R/L=Low or NC; U/D=High or NC



R/L=High; U/D=High or NC



R/L=Low or NC; U/D=Low



R/L=High; U/D=Low

Note 1: TFT-LCD interface signal description is shown in section 6.4.

6.3 The Input Data Format

This product displays 262,144 colors in terms of the 64 grey levels on RGB respectively. The following table demonstrates the display of input data.

Display colors		Data signal (0 : Low level, 1: High level)																	
		R5	R4	R3	R2	R1	R0	G5	G4	G3	G2	G1	G0	B5	B4	B3	B2	B1	B0
Basic colors	Black	0	0	0	0	0	0	0	0	0	0	0	0	0	0	0	0	0	0
	Blue	0	0	0	0	0	0	0	0	0	0	0	0	1	1	1	1	1	1
	Red	1	1	1	1	1	1	0	0	0	0	0	0	0	0	0	0	0	0
	Magenta	1	1	1	1	1	1	0	0	0	0	0	0	1	1	1	1	1	1
	Green	0	0	0	0	0	0	1	1	1	1	1	1	0	0	0	0	0	0
	Cyan	0	0	0	0	0	0	1	1	1	1	1	1	1	1	1	1	1	1
	Yellow	1	1	1	1	1	1	1	1	1	1	1	1	0	0	0	0	0	0
	White	1	1	1	1	1	1	1	1	1	1	1	1	1	1	1	1	1	1
Red grayscale	Black	0	0	0	0	0	0	0	0	0	0	0	0	0	0	0	0	0	0
	Dark	0	0	0	0	0	1	0	0	0	0	0	0	0	0	0	0	0	0
	↑																		
	↓																		
	bright	1	1	1	1	0	1	0	0	0	0	0	0	0	0	0	0	0	0
Red	1	1	1	1	1	0	0	0	0	0	0	0	0	0	0	0	0	0	
Green grayscale	Black	0	0	0	0	0	0	0	0	0	0	0	0	0	0	0	0	0	0
	Dark	0	0	0	0	0	0	0	0	0	0	1	0	0	0	0	0	0	0
	↑																		
	↓																		
	bright	0	0	0	0	0	0	1	1	1	1	0	1	0	0	0	0	0	0
Green	0	0	0	0	0	0	1	1	1	1	1	1	0	0	0	0	0	0	
Blue grayscale	Black	0	0	0	0	0	0	0	0	0	0	0	0	0	0	0	0	0	0
	Dark	0	0	0	0	0	0	0	0	0	0	0	0	0	0	0	0	1	0
	↑																		
	↓																		
	bright	0	0	0	0	0	0	0	0	0	0	0	0	1	1	1	1	0	1
Blue	0	0	0	0	0	0	0	0	0	0	0	0	1	1	1	1	1	0	
Blue	0	0	0	0	0	0	0	0	0	0	0	0	1	1	1	1	1	1	

6.4 TFT- LCD Interface Signal Description

Pin#	Signal Name	Description
1	GND	Ground
2	DOTCLK	Dot clock
3	NC	NC
4	NC	NC
5	GND	Ground
6	R0	Red data(LSB)
7	R1	Red data
8	R2	Red data
9	R3	Red data
10	R4	Red data
11	R5	Red data(MSB)
12	GND	Ground
13	G0	Green data(LSB)
14	G1	Green data
15	G2	Green data
16	G3	Green data
17	G4	Green data
18	G5	Green data(MSB)
19	GND	Ground
20	B0	Blue data(LSB)
21	B1	Blue data
22	B2	Blue data
23	B3	Blue data
24	B4	Blue data
25	B5	Blue data(MSB)
26	GND	Ground
27	DE	Data enable signal
28	VDD	Power supply (3.3V Typ. Only)
29	VDD	Power supply (3.3V Typ. Only)
30	R/L	Horizontal reverse scan
31	U/D	Vertical reverse scan
32	NC	NC
33	GND	Ground

Note 1: "Low" stands for 0V. "High" stands for 3.3V. "NC" stands for "No Connection".

6.5 TFT- LCD Interface Timing

6.5.1 Timing Characteristics

DE mode only

Parameter		Symbol	Min.	Typ.	Max.	Unit
Clock frequency		$1/T_{\text{Clock}}$	5	6	8	MHz
Data	Setup Time	T_{dsu}	12			ns
	Hold Time	T_{dhd}	12			ns
DE	Setup Time	T_{dest}	12			ns
	Hold Time	T_{dehd}	12			ns
HSYNC	Period Time	T_{h}	325	371	438	DCLK
	Display Period	T_{hdisp}		320		
	Back Porch	T_{hbp}	3	43	43	
	Front Porch	T_{hfp}	2	8	75	
	Pulse Width	T_{hw}	2	4	43	
VSYNC	Period Time	T_{v}	244	260	289	HSYNC
	Display Period	T_{vdisp}		240		
	Back Porch	T_{vbp}	2	12	12	
	Front Porch	T_{vfp}	2	8	37	
	Pulse Width	T_{vw}	2	4	12	
Frame Rate		F		60	70	Hz

Note 1: Recommended frame rate is 60 Hz.

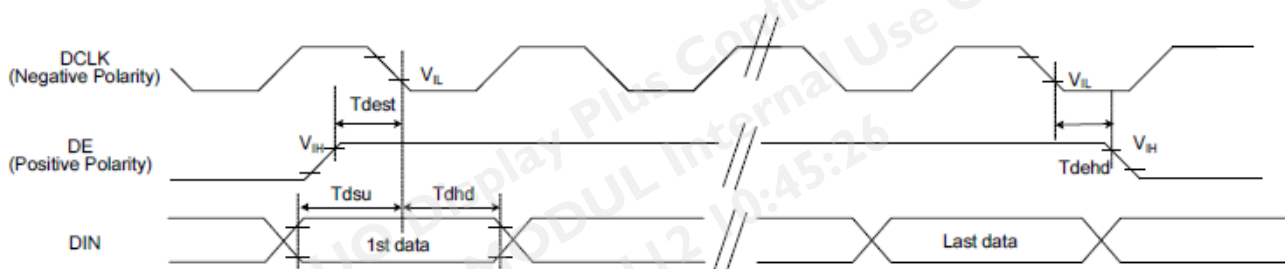

6.7 Power ON/OFF Sequence

VDD power, LCD interface signals and backlight on/off sequence are shown in the following chart. Signals from any system shall be Hi-Z state or low level when VDD is off.

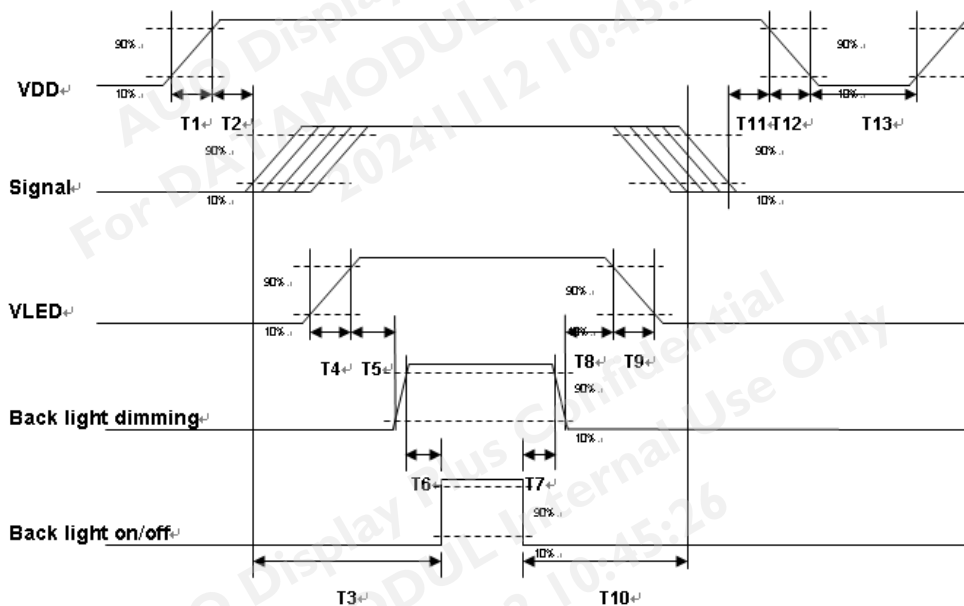

Power ON/OFF sequence timing

Parameter	Value			Units
	Min.	Typ.	Max.	
T1	0.5	-	10	[ms]
T2	30	40	50	[ms]
T3	200	-	-	[ms]
T4	0.5	-	10	[ms]
T5	10	-	-	[ms]
T6	10	-	-	[ms]
T7	0	-	-	[ms]
T8	10	-	-	[ms]
T9	-	-	10	[ms]
T10	110	-	-	[ms]
T11	0	16	50	[ms]
T12	-	-	10	[ms]
T13	1000	-	-	[ms]

ON/OFF sequence should be applied to avoid abnormal function in the display. Please make sure to turn off the power when you plug the cable into the input connector or pull the cable out of the connector.

7. Connector & Pin Assignment

7.1 TFT- LCD Signal (CN1): LCD Connector

Manufacturer	Starconn
Connector Model Number	089H33-000100-G2-R, compatible with IMSA-9637S-33Y902 & ELCO 08-6210--033-340-800+

7.2 LED Backlight Unit (CN2): Backlight Connector

Manufacturer	CviLus
Connector Model Number (female)	CI1106M1HR0-NH or compatible with JST SM06B-SRKS-G-TB
Mating Connector Model Number (male)	JST SHR-06V-BKHF-B or compatible

7.3 LED Light Bar Input (CN3): Light Bar Connector

Manufacturer	STM or compatible
Connector Model Number (male)	P24021P6 or compatible
Mating Connector Model Number (female)	JST / SM06B-SHLK-GTF(HF) or compatible

Pin #	Symbol	Pin Description	Cable color
1	NC	-	-
2	NC	-	-
3	AN1	Channel 1 LED anode	Red
4	CA1	Channel 1 LED cathode	White
5	NC	-	-
6	NC	-	-

7.4 PIN 1 definition of CN1 and CN2

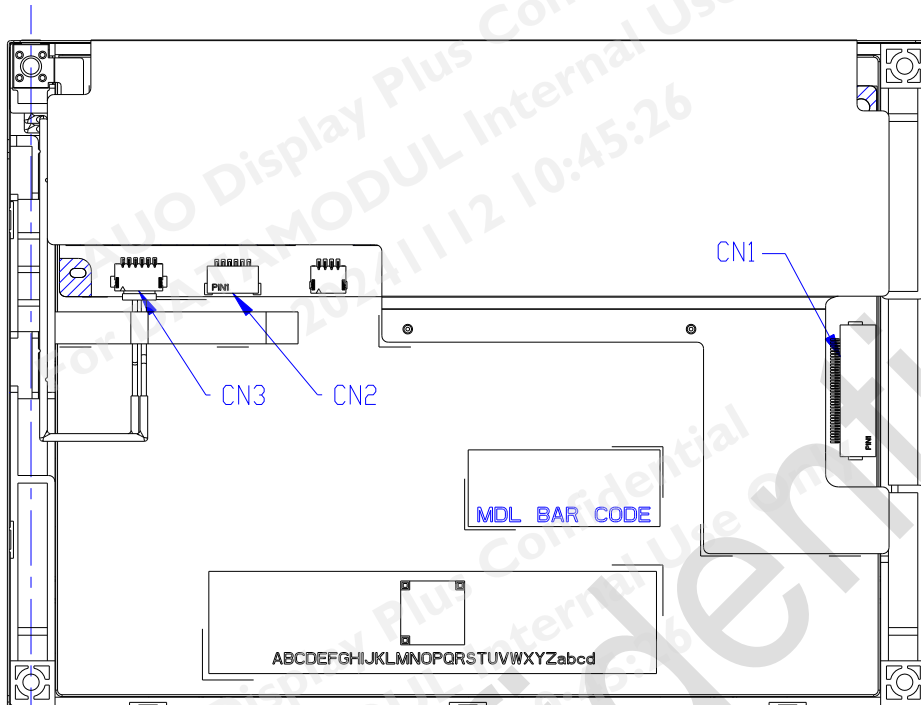

(Rear side of TFT-LCD)

7.5 PIN 1 definition of CN3

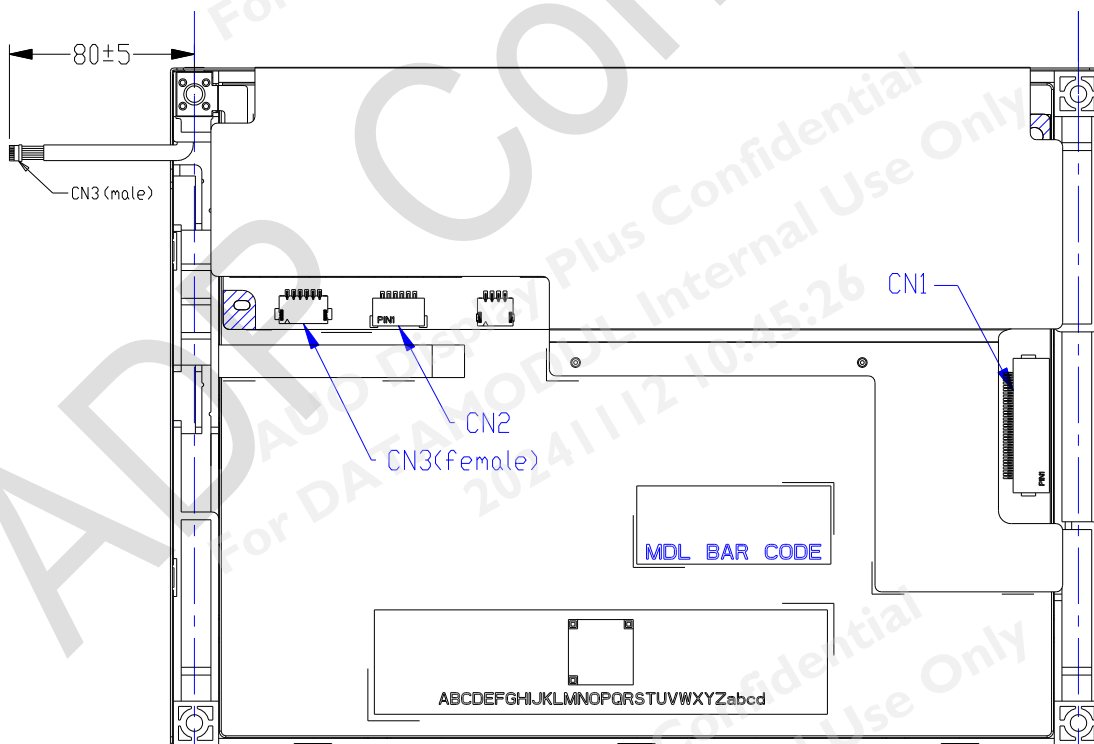

(Rear side of TFT-LCD)

8. Reliability Test Criteria

Items	Required Condition	Remark
Temperature Humidity Bias	40°C/90%,300Hr	Note 2
High Temperature Operation	85°C,300Hr	Note 2
Low Temperature Operation	-30°C,300Hr	Note 2
High Temperature Storage	85°C,300 hours	Note 2
Low Temperature Storage	-30°C ,300 hours	Note 2
Thermal Shock Test	-20°C/30 min ,60°C/30 min ,100cycles	Note 2
Hot Start Test	85°C/1 Hr (min.), power on/off per 5 minutes, repeat 5 times	Note 2
Cold Start Test	-30°C/1 Hr (min.), power on/off per 5 minutes, repeat 5 times	Note 2
Shock Test (Non-Operating)	50G,20ms,Half-sine wave, (±X, ±Y, ±Z)	Note 2
Vibration Test (Non-Operating)	1.5G, 10~200~10Hz, Sine wave, 30mins/axis, 3 direction (X, Y, Z)	Note 2
ESD	Contact Discharge: ±8KV, 150pF(330Ω) 1sec, 8 points, 25 times/point Air Discharge: ±15KV, 150pF(330Ω) 1sec, 8 points, 25 times/point	Note 1,2
Altitude Test	Operating: 14,000 ft, Ramp: 2000 ft/min, 8hrs Non-operating: 40,000 ft, Ramp: 2000 ft/min, 24hrs	Note 2

Note1: According to EN61000-4-2 ESD class B criteria, some performance degradation is allowed. TFT-LCD module is self-recoverable, no data lost and no hardware failures after test.

Note2:

- Water condensation is not allowed for each test items.
- Each test is done by new TFT-LCD module. Don't use the same TFT-LCD module repeatedly for reliability test.
- The reliability test is performed only to examine the TFT-LCD module capability.
- To inspect TFT-LCD module after reliability test, please store it at room temperature and room humidity for 24 hours at least in advance.

9. Mechanical Characteristics

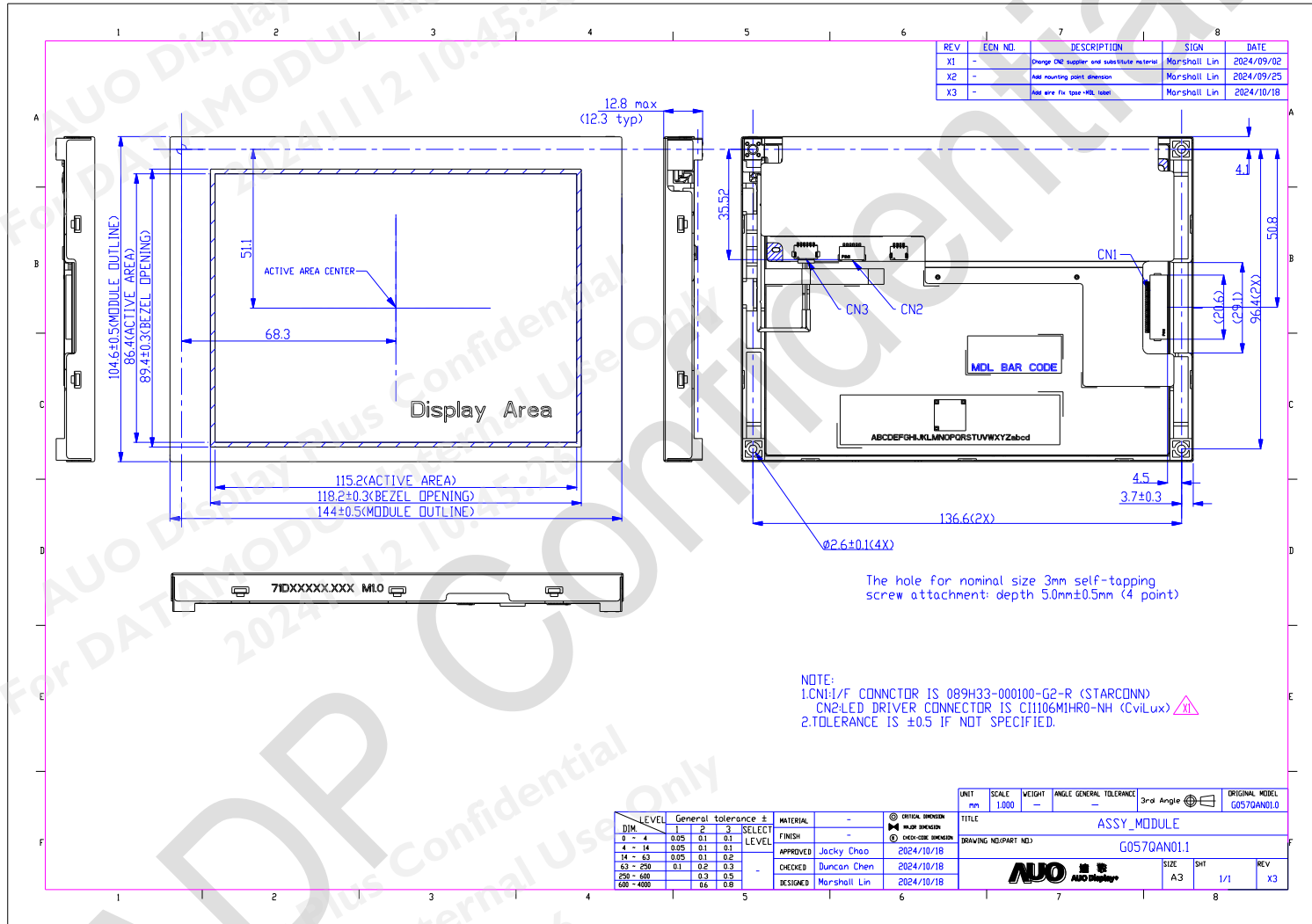

Note: Please evaluate the tightening torque according to customer's application.

10. Label and Packaging

10.1 Shipping Label (on the rear side of TFT-LCD display)



10.2 Carton Package

Max. capacity: 60 pieces TFT-LCD module per carton

Max. weight: 12.95 kg per carton

Outside dimension of carton: 520(L)mm* 340(W)mm* 250(H)mm

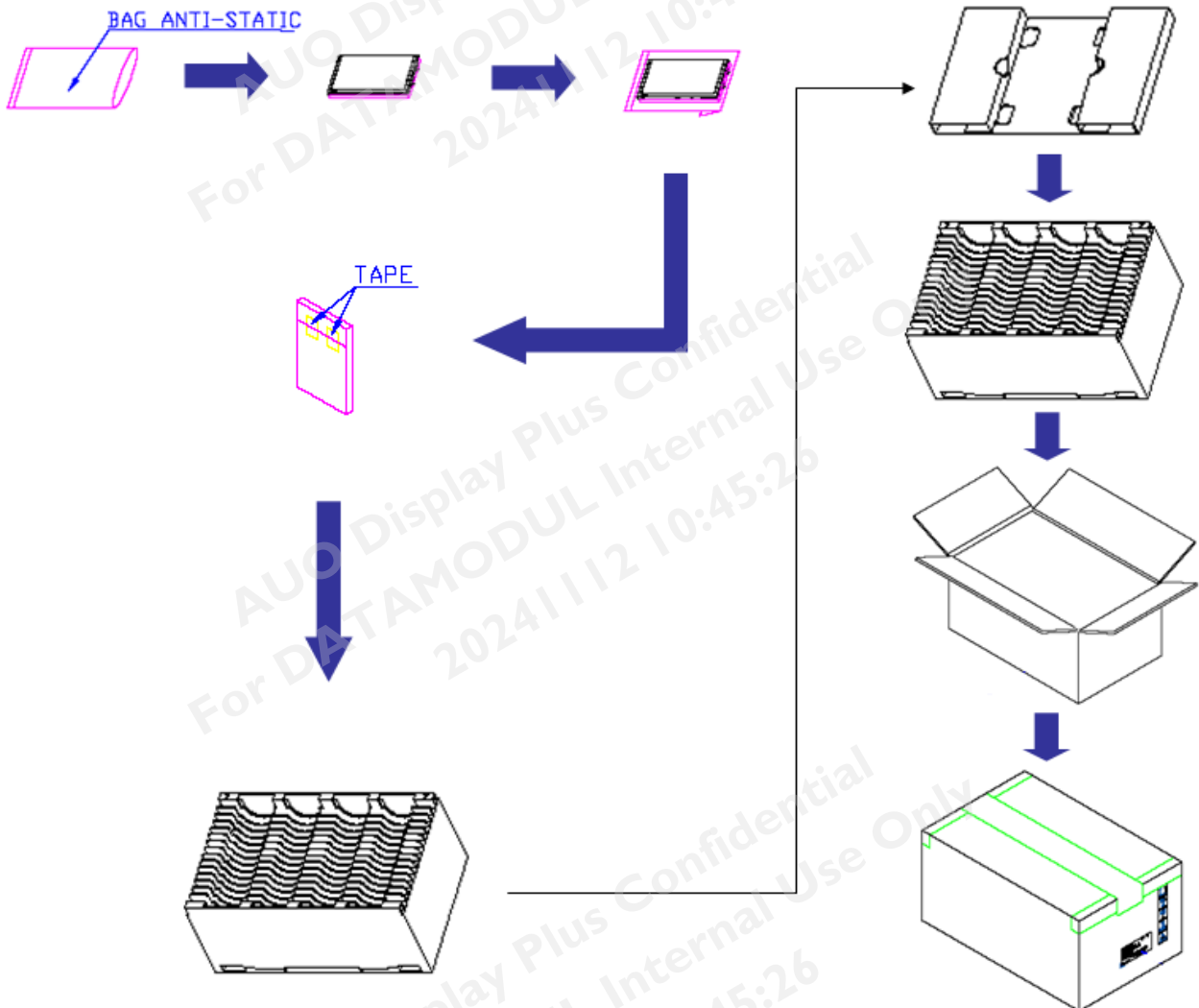

11 Safety

11.1 Keen Edge Requirements

There will be no keen edges or corners on the display assembly that could cause injury.

11.2 Materials

11.2.1 Toxicity

There will be no carcinogenic materials used anywhere in the TFT-LCD module. If toxic materials are used, they will be reviewed and approved by the responsible AUO toxicologist.

11.2.2 Flammability

All components including electrical components that do not meet the flammability grade UL94-V1 in the TFT-LCD Module will complete the flammability rating exception approval process.

The printed circuit board will be made from material rated 94-V1 or better. The actual UL flammability rating will be printed on the printed circuit board.

11.3 Capacitors

If any polarized capacitors are used in the TFT-LCD module, provisions will be made to keep them from being inserted backwards.

11.4 National Test Lab Requirement

The display module will satisfy all requirements for compliance to: IEC/UL 62368-1

DATA MODUL

Passion Displayed

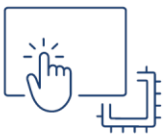

All good things come in threes:

With **Hardware**, **Software** and **Services**, we realise unique display solutions that turn your ideas into reality.

www.data-modul.com

