

Specification

G057QAN01.0

5.7" - 320x240 – RGB/TTL

Spec Revision: 0.4
Revision Date: 12.03.2025

Note: This specification is subject to change without prior notice

(V) Preliminary Specifications
 () Final Specifications

Module	5.7 Inch Color TFT-LCD
Model Name	G057QAN01.0

Customer	Date
_____	_____
Checked & Approved by	
_____	_____
<p>Note: This Specification is subject to change without notice.</p>	

Approved by	Date
Castor Chan	2025/03/12
Prepared by	
Emma Lin	2025/03/12
<p>General Display Business Unit / AUO Display Plus Corporation</p>	

Contents

1. Operating Precautions	7
2. General Description	8
2.1 Display Characteristics	8
2.2 Optical Characteristics	9
3. Functional Block Diagram	12
4. Absolute Maximum Ratings.....	13
4.1 Absolute Ratings of TFT LCD Module.....	13
4.2 Absolute Ratings of Environment.....	13
5. Electrical Characteristics.....	14
5.1 TFT LCD Module	14
5.2 Backlight Unit.....	15
6. Signal Characteristic.....	16
6.1 Pixel Format Image.....	16
6.2 Scanning Direction.....	16
6.3 TFT- LCD Interface Signal Description	17
6.4 The Input Data Format.....	18
6.5 Interface Timing	19
6.6 LED Backlight Unit Interface Signal Description	20
6.7 Power ON/OFF Sequence	21
7. Connector & Pin Assignment	22
7.1 TFT- LCD Signal (CN1): LCD Connector	22
7.2 LED Backlight Unit (CN2): Backlight Connector	22
7.3 LED Light Bar Input (CN3): Light Bar Connector	22
7.4 Connector Illustration	23
7.4.1 PIN 1 definition of CN1 and CN2	23
7.4.2 PIN 1 definition of CN3	23
8. Reliability Test Criteria.....	24
9. Mechanical Characteristics	25
10. Label and Packaging.....	26
10.1 Shipping Label (on the rear side of TFT-LCD display)	26
10.2 Carton Package	26
11 Safety.....	27
11.1 Sharp Edge Requirements.....	27
11.2 Materials.....	27
11.3 Capacitors.....	27
11.4 National Test Lab Requirement.....	27

Record of Revision

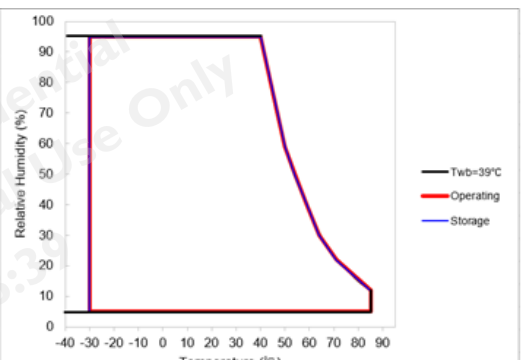
Version and Date	Page	Old description	New Description																																																																																																																																																																																																									
0.0 2024/03/27	All		First draft of Preliminary specification.																																																																																																																																																																																																									
0.1 2024/09/10	6	Typical Power Consumption ^{1,2} [Watt] ^{1,2} TBD ^{1,2} @ All white pattern, Full Load and VLED=12V ^{1,2}	Typical Power Consumption ^{1,2} [Watt] ^{1,2} 1.42 typ ^{1,2} @ All white pattern, Full Load and VLED=12V ^{1,2}																																																																																																																																																																																																									
	7	Viewing Angle ^{1,2} <table border="1" style="display: inline-table; vertical-align: middle;"> <tr> <td>(degree)^{1,2} (degree)^{1,2}</td> <td>Horizontal CR = 10</td> <td>(Right) (Left)^{1,2}</td> <td>70^{1,2} 70^{1,2}</td> <td>89^{1,2} 89^{1,2}</td> <td>---^{1,2} ---^{1,2}</td> <td rowspan="2">Note 6^{1,2}</td> </tr> <tr> <td>(degree)^{1,2} (degree)^{1,2}</td> <td>Vertical CR = 10</td> <td>(Upper) (Lower)^{1,2}</td> <td>70^{1,2} 70^{1,2}</td> <td>89^{1,2} 89^{1,2}</td> <td>---^{1,2} ---^{1,2}</td> </tr> </table>	(degree) ^{1,2} (degree) ^{1,2}	Horizontal CR = 10	(Right) (Left) ^{1,2}	70 ^{1,2} 70 ^{1,2}	89 ^{1,2} 89 ^{1,2}	--- ^{1,2} --- ^{1,2}	Note 6 ^{1,2}	(degree) ^{1,2} (degree) ^{1,2}	Vertical CR = 10	(Upper) (Lower) ^{1,2}	70 ^{1,2} 70 ^{1,2}	89 ^{1,2} 89 ^{1,2}	--- ^{1,2} --- ^{1,2}	Viewing Angle ^{1,2} <table border="1" style="display: inline-table; vertical-align: middle;"> <tr> <td>(degree)^{1,2} (degree)^{1,2}</td> <td>Horizontal CR = 10</td> <td>(Right) (Left)^{1,2}</td> <td>80^{1,2} 80^{1,2}</td> <td>89^{1,2} 89^{1,2}</td> <td>---^{1,2} ---^{1,2}</td> <td rowspan="2">Note 6^{1,2}</td> </tr> <tr> <td>(degree)^{1,2} (degree)^{1,2}</td> <td>Vertical CR = 10</td> <td>(Upper) (Lower)^{1,2}</td> <td>80^{1,2} 80^{1,2}</td> <td>89^{1,2} 89^{1,2}</td> <td>---^{1,2} ---^{1,2}</td> </tr> </table>	(degree) ^{1,2} (degree) ^{1,2}	Horizontal CR = 10	(Right) (Left) ^{1,2}	80 ^{1,2} 80 ^{1,2}	89 ^{1,2} 89 ^{1,2}	--- ^{1,2} --- ^{1,2}	Note 6 ^{1,2}	(degree) ^{1,2} (degree) ^{1,2}	Vertical CR = 10	(Upper) (Lower) ^{1,2}	80 ^{1,2} 80 ^{1,2}	89 ^{1,2} 89 ^{1,2}	--- ^{1,2} --- ^{1,2}																																																																																																																																																																															
(degree) ^{1,2} (degree) ^{1,2}	Horizontal CR = 10	(Right) (Left) ^{1,2}	70 ^{1,2} 70 ^{1,2}	89 ^{1,2} 89 ^{1,2}	--- ^{1,2} --- ^{1,2}	Note 6 ^{1,2}																																																																																																																																																																																																						
(degree) ^{1,2} (degree) ^{1,2}	Vertical CR = 10	(Upper) (Lower) ^{1,2}	70 ^{1,2} 70 ^{1,2}	89 ^{1,2} 89 ^{1,2}	--- ^{1,2} --- ^{1,2}																																																																																																																																																																																																							
(degree) ^{1,2} (degree) ^{1,2}	Horizontal CR = 10	(Right) (Left) ^{1,2}	80 ^{1,2} 80 ^{1,2}	89 ^{1,2} 89 ^{1,2}	--- ^{1,2} --- ^{1,2}	Note 6 ^{1,2}																																																																																																																																																																																																						
(degree) ^{1,2} (degree) ^{1,2}	Vertical CR = 10	(Upper) (Lower) ^{1,2}	80 ^{1,2} 80 ^{1,2}	89 ^{1,2} 89 ^{1,2}	--- ^{1,2} --- ^{1,2}																																																																																																																																																																																																							
	11		<p>Add temperature and Humidity curve</p> <h3>4.2 Absolute Ratings of Environment^{1,2}</h3>  <p>The graph plots Relative Humidity (%) on the y-axis (0 to 100) against Temperature (°C) on the x-axis (-40 to 90). Three curves are shown: Twb=39°C (black), Operating (red), and Storage (blue). The Operating curve shows a sharp drop in humidity starting around 40°C, reaching approximately 10% at 80°C. The Storage curve remains at 100% humidity until about 60°C, then drops to 10% at 80°C. The Twb=39°C curve is constant at 100% humidity across the entire temperature range.</p>																																																																																																																																																																																																									
	13	<p>5.2.1 Parameter guideline for LED^{1,2} Following characteristics are measured under stable condition using a LED driving board at 25°C (Room Temperature).^{1,2}</p> <table border="1"> <thead> <tr> <th>Symbol^{1,2}</th> <th>Parameter^{1,2}</th> <th>Min^{1,2}</th> <th>Typ^{1,2}</th> <th>Max^{1,2}</th> <th>Units^{1,2}</th> <th>Remark^{1,2}</th> </tr> </thead> <tbody> <tr> <td>V_{LED}^{1,2}</td> <td>Input Voltage^{1,2}</td> <td>9^{1,2}</td> <td>12^{1,2}</td> <td>20^{1,2}</td> <td>Volt^{1,2}</td> <td rowspan="2">V_{LED}=12V, D_{DIM}=100%^{1,2}</td> </tr> <tr> <td>I_{LED}^{1,2}</td> <td>Input Current^{1,2}</td> <td>---</td> <td>0.1^{1,2}</td> <td>0.11^{1,2}</td> <td>A^{1,2}</td> </tr> <tr> <td>P_{LED}^{1,2}</td> <td>Power Consumption^{1,2}</td> <td>---</td> <td>1.21^{1,2}</td> <td>1.34^{1,2}</td> <td>W^{1,2}</td> <td>V_{LED}=12V, D_{DIM}=100%^{1,2}</td> </tr> <tr> <td>I_{rush,LED}^{1,2}</td> <td>Inrush Current^{1,2}</td> <td>---</td> <td>---</td> <td>1.5^{1,2}</td> <td>A^{1,2}</td> <td>V_{LED}=12V, D_{DIM}=100%^{1,2}</td> </tr> <tr> <td>V_{PWM DIM}^{1,2}</td> <td>Dimming control Voltage High^{1,2}</td> <td>2.0^{1,2}</td> <td>3.3^{1,2}</td> <td>5^{1,2}</td> <td>Volt^{1,2}</td> <td rowspan="2">Note 1,2^{1,2}</td> </tr> <tr> <td>V_{PWM DIM}^{1,2}</td> <td>Dimming control Voltage Low^{1,2}</td> <td>---</td> <td>---</td> <td>0.15^{1,2}</td> <td>Volt^{1,2}</td> </tr> <tr> <td>F_{PWM}^{1,2}</td> <td>Dimming Frequency^{1,2}</td> <td>200^{1,2}</td> <td>---</td> <td>25K^{1,2}</td> <td>Hz^{1,2}</td> <td rowspan="2">Note 1,2^{1,2}</td> </tr> <tr> <td>D_{DIM}^{1,2}</td> <td>Dimming duty cycle^{1,2}</td> <td>1^{1,2}</td> <td>---</td> <td>100^{1,2}</td> <td>%^{1,2}</td> </tr> <tr> <td>V_{LED On/Off}^{1,2}</td> <td>On Control Voltage^{1,2}</td> <td>2^{1,2}</td> <td>3.3^{1,2}</td> <td>5^{1,2}</td> <td>Volt^{1,2}</td> <td rowspan="2">Note 3, 4^{1,2}</td> </tr> <tr> <td>V_{LED On/Off}^{1,2}</td> <td>Off Control Voltage^{1,2}</td> <td>---</td> <td>---</td> <td>0.6^{1,2}</td> <td>Volt^{1,2}</td> </tr> <tr> <td>I_F^{1,2}</td> <td>LED Forward Current^{1,2}</td> <td>---</td> <td>40^{1,2}</td> <td>---</td> <td>mA^{1,2}</td> <td>Ta = 25°C^{1,2}</td> </tr> <tr> <td rowspan="2">V_F^{1,2}</td> <td rowspan="2">LED Forward Voltage^{1,2}</td> <td>---</td> <td>---</td> <td>---</td> <td>Volt^{1,2}</td> <td>IF = 40mA, Ta = -30°C^{1,2}</td> </tr> <tr> <td>---</td> <td>22.4^{1,2}</td> <td>24^{1,2}</td> <td>26.4^{1,2}</td> <td>Volt^{1,2}</td> <td>IF = 40mA, Ta = 25°C^{1,2}</td> </tr> <tr> <td rowspan="2">Operating Life^{1,2}</td> <td rowspan="2"></td> <td>---</td> <td>---</td> <td>---</td> <td>Hrs^{1,2}</td> <td>IF = 40mA, Ta = 85°C^{1,2}</td> </tr> <tr> <td>70,000^{1,2}</td> <td>---</td> <td>---</td> <td>---</td> <td>Hrs^{1,2}</td> <td>Note 5, 6, 7^{1,2}</td> </tr> </tbody> </table>	Symbol ^{1,2}	Parameter ^{1,2}	Min ^{1,2}	Typ ^{1,2}	Max ^{1,2}	Units ^{1,2}	Remark ^{1,2}	V _{LED} ^{1,2}	Input Voltage ^{1,2}	9 ^{1,2}	12 ^{1,2}	20 ^{1,2}	Volt ^{1,2}	V _{LED} =12V, D _{DIM} =100% ^{1,2}	I _{LED} ^{1,2}	Input Current ^{1,2}	---	0.1 ^{1,2}	0.11 ^{1,2}	A ^{1,2}	P _{LED} ^{1,2}	Power Consumption ^{1,2}	---	1.21 ^{1,2}	1.34 ^{1,2}	W ^{1,2}	V _{LED} =12V, D _{DIM} =100% ^{1,2}	I _{rush,LED} ^{1,2}	Inrush Current ^{1,2}	---	---	1.5 ^{1,2}	A ^{1,2}	V _{LED} =12V, D _{DIM} =100% ^{1,2}	V _{PWM DIM} ^{1,2}	Dimming control Voltage High ^{1,2}	2.0 ^{1,2}	3.3 ^{1,2}	5 ^{1,2}	Volt ^{1,2}	Note 1,2 ^{1,2}	V _{PWM DIM} ^{1,2}	Dimming control Voltage Low ^{1,2}	---	---	0.15 ^{1,2}	Volt ^{1,2}	F _{PWM} ^{1,2}	Dimming Frequency ^{1,2}	200 ^{1,2}	---	25K ^{1,2}	Hz ^{1,2}	Note 1,2 ^{1,2}	D _{DIM} ^{1,2}	Dimming duty cycle ^{1,2}	1 ^{1,2}	---	100 ^{1,2}	% ^{1,2}	V _{LED On/Off} ^{1,2}	On Control Voltage ^{1,2}	2 ^{1,2}	3.3 ^{1,2}	5 ^{1,2}	Volt ^{1,2}	Note 3, 4 ^{1,2}	V _{LED On/Off} ^{1,2}	Off Control Voltage ^{1,2}	---	---	0.6 ^{1,2}	Volt ^{1,2}	I _F ^{1,2}	LED Forward Current ^{1,2}	---	40 ^{1,2}	---	mA ^{1,2}	Ta = 25°C ^{1,2}	V _F ^{1,2}	LED Forward Voltage ^{1,2}	---	---	---	Volt ^{1,2}	IF = 40mA, Ta = -30°C ^{1,2}	---	22.4 ^{1,2}	24 ^{1,2}	26.4 ^{1,2}	Volt ^{1,2}	IF = 40mA, Ta = 25°C ^{1,2}	Operating Life ^{1,2}		---	---	---	Hrs ^{1,2}	IF = 40mA, Ta = 85°C ^{1,2}	70,000 ^{1,2}	---	---	---	Hrs ^{1,2}	Note 5, 6, 7 ^{1,2}	<p>5.2.1 Parameter guideline for LED^{1,2} Following characteristics are measured under stable condition using a LED driving board at 25°C (Room Temperature).^{1,2}</p> <table border="1"> <thead> <tr> <th>Symbol^{1,2}</th> <th>Parameter^{1,2}</th> <th>Min^{1,2}</th> <th>Typ^{1,2}</th> <th>Max^{1,2}</th> <th>Units^{1,2}</th> <th>Remark^{1,2}</th> </tr> </thead> <tbody> <tr> <td>V_{LED}^{1,2}</td> <td>Input Voltage^{1,2}</td> <td>9^{1,2}</td> <td>12^{1,2}</td> <td>20^{1,2}</td> <td>Volt^{1,2}</td> <td rowspan="2">V_{LED}=12V, D_{DIM}=100%^{1,2}</td> </tr> <tr> <td>I_{LED}^{1,2}</td> <td>Input Current^{1,2}</td> <td>---</td> <td>0.1^{1,2}</td> <td>0.11^{1,2}</td> <td>A^{1,2}</td> </tr> <tr> <td>P_{LED}^{1,2}</td> <td>Power Consumption^{1,2}</td> <td>---</td> <td>1.33^{1,2}</td> <td>1.39^{1,2}</td> <td>W^{1,2}</td> <td>V_{LED}=12V, D_{DIM}=100%^{1,2}</td> </tr> <tr> <td>I_{rush,LED}^{1,2}</td> <td>Inrush Current^{1,2}</td> <td>---</td> <td>---</td> <td>1.5^{1,2}</td> <td>A^{1,2}</td> <td>V_{LED}=12V, D_{DIM}=100%^{1,2}</td> </tr> <tr> <td>V_{PWM DIM}^{1,2}</td> <td>Dimming control Voltage High^{1,2}</td> <td>2.0^{1,2}</td> <td>3.3^{1,2}</td> <td>5^{1,2}</td> <td>Volt^{1,2}</td> <td rowspan="2">Note 1,2^{1,2}</td> </tr> <tr> <td>V_{PWM DIM}^{1,2}</td> <td>Dimming control Voltage Low^{1,2}</td> <td>---</td> <td>---</td> <td>0.15^{1,2}</td> <td>Volt^{1,2}</td> </tr> <tr> <td>F_{PWM}^{1,2}</td> <td>Dimming Frequency^{1,2}</td> <td>200^{1,2}</td> <td>---</td> <td>25K^{1,2}</td> <td>Hz^{1,2}</td> <td rowspan="2">Note 1,2^{1,2}</td> </tr> <tr> <td>D_{DIM}^{1,2}</td> <td>Dimming duty cycle^{1,2}</td> <td>1^{1,2}</td> <td>---</td> <td>100^{1,2}</td> <td>%^{1,2}</td> </tr> <tr> <td>V_{LED On/Off}^{1,2}</td> <td>On Control Voltage^{1,2}</td> <td>2^{1,2}</td> <td>3.3^{1,2}</td> <td>5^{1,2}</td> <td>Volt^{1,2}</td> <td rowspan="2">Note 3, 4^{1,2}</td> </tr> <tr> <td>V_{LED On/Off}^{1,2}</td> <td>Off Control Voltage^{1,2}</td> <td>---</td> <td>---</td> <td>0.6^{1,2}</td> <td>Volt^{1,2}</td> </tr> <tr> <td>I_F^{1,2}</td> <td>LED Forward Current^{1,2}</td> <td>---</td> <td>50^{1,2}</td> <td>---</td> <td>mA^{1,2}</td> <td>Ta = 25°C^{1,2}</td> </tr> <tr> <td>V_F^{1,2}</td> <td>LED Forward Voltage^{1,2}</td> <td>---</td> <td>22.4^{1,2}</td> <td>23.6^{1,2}</td> <td>24.8^{1,2}</td> <td>Volt^{1,2}</td> <td>IF = 50mA, Ta = 25°C^{1,2}</td> </tr> <tr> <td>Operating Life^{1,2}</td> <td></td> <td>70,000^{1,2}</td> <td>---</td> <td>---</td> <td>Hrs^{1,2}</td> <td>Note 5, 6, 7^{1,2}</td> </tr> </tbody> </table>	Symbol ^{1,2}	Parameter ^{1,2}	Min ^{1,2}	Typ ^{1,2}	Max ^{1,2}	Units ^{1,2}	Remark ^{1,2}	V _{LED} ^{1,2}	Input Voltage ^{1,2}	9 ^{1,2}	12 ^{1,2}	20 ^{1,2}	Volt ^{1,2}	V _{LED} =12V, D _{DIM} =100% ^{1,2}	I _{LED} ^{1,2}	Input Current ^{1,2}	---	0.1 ^{1,2}	0.11 ^{1,2}	A ^{1,2}	P _{LED} ^{1,2}	Power Consumption ^{1,2}	---	1.33 ^{1,2}	1.39 ^{1,2}	W ^{1,2}	V _{LED} =12V, D _{DIM} =100% ^{1,2}	I _{rush,LED} ^{1,2}	Inrush Current ^{1,2}	---	---	1.5 ^{1,2}	A ^{1,2}	V _{LED} =12V, D _{DIM} =100% ^{1,2}	V _{PWM DIM} ^{1,2}	Dimming control Voltage High ^{1,2}	2.0 ^{1,2}	3.3 ^{1,2}	5 ^{1,2}	Volt ^{1,2}	Note 1,2 ^{1,2}	V _{PWM DIM} ^{1,2}	Dimming control Voltage Low ^{1,2}	---	---	0.15 ^{1,2}	Volt ^{1,2}	F _{PWM} ^{1,2}	Dimming Frequency ^{1,2}	200 ^{1,2}	---	25K ^{1,2}	Hz ^{1,2}	Note 1,2 ^{1,2}	D _{DIM} ^{1,2}	Dimming duty cycle ^{1,2}	1 ^{1,2}	---	100 ^{1,2}	% ^{1,2}	V _{LED On/Off} ^{1,2}	On Control Voltage ^{1,2}	2 ^{1,2}	3.3 ^{1,2}	5 ^{1,2}	Volt ^{1,2}	Note 3, 4 ^{1,2}	V _{LED On/Off} ^{1,2}	Off Control Voltage ^{1,2}	---	---	0.6 ^{1,2}	Volt ^{1,2}	I _F ^{1,2}	LED Forward Current ^{1,2}	---	50 ^{1,2}	---	mA ^{1,2}	Ta = 25°C ^{1,2}	V _F ^{1,2}	LED Forward Voltage ^{1,2}	---	22.4 ^{1,2}	23.6 ^{1,2}	24.8 ^{1,2}	Volt ^{1,2}	IF = 50mA, Ta = 25°C ^{1,2}	Operating Life ^{1,2}		70,000 ^{1,2}	---	---	Hrs ^{1,2}	Note 5, 6, 7 ^{1,2}
Symbol ^{1,2}	Parameter ^{1,2}	Min ^{1,2}	Typ ^{1,2}	Max ^{1,2}	Units ^{1,2}	Remark ^{1,2}																																																																																																																																																																																																						
V _{LED} ^{1,2}	Input Voltage ^{1,2}	9 ^{1,2}	12 ^{1,2}	20 ^{1,2}	Volt ^{1,2}	V _{LED} =12V, D _{DIM} =100% ^{1,2}																																																																																																																																																																																																						
I _{LED} ^{1,2}	Input Current ^{1,2}	---	0.1 ^{1,2}	0.11 ^{1,2}	A ^{1,2}																																																																																																																																																																																																							
P _{LED} ^{1,2}	Power Consumption ^{1,2}	---	1.21 ^{1,2}	1.34 ^{1,2}	W ^{1,2}	V _{LED} =12V, D _{DIM} =100% ^{1,2}																																																																																																																																																																																																						
I _{rush,LED} ^{1,2}	Inrush Current ^{1,2}	---	---	1.5 ^{1,2}	A ^{1,2}	V _{LED} =12V, D _{DIM} =100% ^{1,2}																																																																																																																																																																																																						
V _{PWM DIM} ^{1,2}	Dimming control Voltage High ^{1,2}	2.0 ^{1,2}	3.3 ^{1,2}	5 ^{1,2}	Volt ^{1,2}	Note 1,2 ^{1,2}																																																																																																																																																																																																						
V _{PWM DIM} ^{1,2}	Dimming control Voltage Low ^{1,2}	---	---	0.15 ^{1,2}	Volt ^{1,2}																																																																																																																																																																																																							
F _{PWM} ^{1,2}	Dimming Frequency ^{1,2}	200 ^{1,2}	---	25K ^{1,2}	Hz ^{1,2}	Note 1,2 ^{1,2}																																																																																																																																																																																																						
D _{DIM} ^{1,2}	Dimming duty cycle ^{1,2}	1 ^{1,2}	---	100 ^{1,2}	% ^{1,2}																																																																																																																																																																																																							
V _{LED On/Off} ^{1,2}	On Control Voltage ^{1,2}	2 ^{1,2}	3.3 ^{1,2}	5 ^{1,2}	Volt ^{1,2}	Note 3, 4 ^{1,2}																																																																																																																																																																																																						
V _{LED On/Off} ^{1,2}	Off Control Voltage ^{1,2}	---	---	0.6 ^{1,2}	Volt ^{1,2}																																																																																																																																																																																																							
I _F ^{1,2}	LED Forward Current ^{1,2}	---	40 ^{1,2}	---	mA ^{1,2}	Ta = 25°C ^{1,2}																																																																																																																																																																																																						
V _F ^{1,2}	LED Forward Voltage ^{1,2}	---	---	---	Volt ^{1,2}	IF = 40mA, Ta = -30°C ^{1,2}																																																																																																																																																																																																						
		---	22.4 ^{1,2}	24 ^{1,2}	26.4 ^{1,2}	Volt ^{1,2}	IF = 40mA, Ta = 25°C ^{1,2}																																																																																																																																																																																																					
Operating Life ^{1,2}		---	---	---	Hrs ^{1,2}	IF = 40mA, Ta = 85°C ^{1,2}																																																																																																																																																																																																						
		70,000 ^{1,2}	---	---	---	Hrs ^{1,2}	Note 5, 6, 7 ^{1,2}																																																																																																																																																																																																					
Symbol ^{1,2}	Parameter ^{1,2}	Min ^{1,2}	Typ ^{1,2}	Max ^{1,2}	Units ^{1,2}	Remark ^{1,2}																																																																																																																																																																																																						
V _{LED} ^{1,2}	Input Voltage ^{1,2}	9 ^{1,2}	12 ^{1,2}	20 ^{1,2}	Volt ^{1,2}	V _{LED} =12V, D _{DIM} =100% ^{1,2}																																																																																																																																																																																																						
I _{LED} ^{1,2}	Input Current ^{1,2}	---	0.1 ^{1,2}	0.11 ^{1,2}	A ^{1,2}																																																																																																																																																																																																							
P _{LED} ^{1,2}	Power Consumption ^{1,2}	---	1.33 ^{1,2}	1.39 ^{1,2}	W ^{1,2}	V _{LED} =12V, D _{DIM} =100% ^{1,2}																																																																																																																																																																																																						
I _{rush,LED} ^{1,2}	Inrush Current ^{1,2}	---	---	1.5 ^{1,2}	A ^{1,2}	V _{LED} =12V, D _{DIM} =100% ^{1,2}																																																																																																																																																																																																						
V _{PWM DIM} ^{1,2}	Dimming control Voltage High ^{1,2}	2.0 ^{1,2}	3.3 ^{1,2}	5 ^{1,2}	Volt ^{1,2}	Note 1,2 ^{1,2}																																																																																																																																																																																																						
V _{PWM DIM} ^{1,2}	Dimming control Voltage Low ^{1,2}	---	---	0.15 ^{1,2}	Volt ^{1,2}																																																																																																																																																																																																							
F _{PWM} ^{1,2}	Dimming Frequency ^{1,2}	200 ^{1,2}	---	25K ^{1,2}	Hz ^{1,2}	Note 1,2 ^{1,2}																																																																																																																																																																																																						
D _{DIM} ^{1,2}	Dimming duty cycle ^{1,2}	1 ^{1,2}	---	100 ^{1,2}	% ^{1,2}																																																																																																																																																																																																							
V _{LED On/Off} ^{1,2}	On Control Voltage ^{1,2}	2 ^{1,2}	3.3 ^{1,2}	5 ^{1,2}	Volt ^{1,2}	Note 3, 4 ^{1,2}																																																																																																																																																																																																						
V _{LED On/Off} ^{1,2}	Off Control Voltage ^{1,2}	---	---	0.6 ^{1,2}	Volt ^{1,2}																																																																																																																																																																																																							
I _F ^{1,2}	LED Forward Current ^{1,2}	---	50 ^{1,2}	---	mA ^{1,2}	Ta = 25°C ^{1,2}																																																																																																																																																																																																						
V _F ^{1,2}	LED Forward Voltage ^{1,2}	---	22.4 ^{1,2}	23.6 ^{1,2}	24.8 ^{1,2}	Volt ^{1,2}	IF = 50mA, Ta = 25°C ^{1,2}																																																																																																																																																																																																					
Operating Life ^{1,2}		70,000 ^{1,2}	---	---	Hrs ^{1,2}	Note 5, 6, 7 ^{1,2}																																																																																																																																																																																																						
	20	<p>7.2 LED Backlight Unit (CN2): Backlight Connector^{1,2}</p> <table border="1"> <tr> <td>Manufacturer^{1,2}</td> <td>JST^{1,2}</td> </tr> <tr> <td>Connector Model Number^{1,2}</td> <td>SM06B-SRKS-G-TB^{1,2} compatible with JST SM06B-SRSS-TB (LS) (SN)^{1,2}</td> </tr> <tr> <td>Mating Connector Model Number^{1,2}</td> <td>JST SHR-06V-BKHF-B or compatible^{1,2}</td> </tr> </table>	Manufacturer ^{1,2}	JST ^{1,2}	Connector Model Number ^{1,2}	SM06B-SRKS-G-TB ^{1,2} compatible with JST SM06B-SRSS-TB (LS) (SN) ^{1,2}	Mating Connector Model Number ^{1,2}	JST SHR-06V-BKHF-B or compatible ^{1,2}	<p>7.2 LED Backlight Unit (CN2): Backlight Connector^{1,2}</p> <table border="1"> <tr> <td>Manufacturer^{1,2}</td> <td>CvLux^{1,2}</td> </tr> <tr> <td>Connector Model Number (female)^{1,2}</td> <td>CI1106M1HR0-NH or^{1,2} compatible with SM06B-SRKS-G-TB^{1,2}</td> </tr> <tr> <td>Mating Connector Model Number (male)^{1,2}</td> <td>JST SHR-06V-BKHF-B or compatible^{1,2}</td> </tr> </table>	Manufacturer ^{1,2}	CvLux ^{1,2}	Connector Model Number (female) ^{1,2}	CI1106M1HR0-NH or ^{1,2} compatible with SM06B-SRKS-G-TB ^{1,2}	Mating Connector Model Number (male) ^{1,2}	JST SHR-06V-BKHF-B or compatible ^{1,2}																																																																																																																																																																																													
Manufacturer ^{1,2}	JST ^{1,2}																																																																																																																																																																																																											
Connector Model Number ^{1,2}	SM06B-SRKS-G-TB ^{1,2} compatible with JST SM06B-SRSS-TB (LS) (SN) ^{1,2}																																																																																																																																																																																																											
Mating Connector Model Number ^{1,2}	JST SHR-06V-BKHF-B or compatible ^{1,2}																																																																																																																																																																																																											
Manufacturer ^{1,2}	CvLux ^{1,2}																																																																																																																																																																																																											
Connector Model Number (female) ^{1,2}	CI1106M1HR0-NH or ^{1,2} compatible with SM06B-SRKS-G-TB ^{1,2}																																																																																																																																																																																																											
Mating Connector Model Number (male) ^{1,2}	JST SHR-06V-BKHF-B or compatible ^{1,2}																																																																																																																																																																																																											
	20		<p>Add LED light bar connector & cable information</p> <p>7.3 LED Light Bar Input (CN3): Light Bar Connector^{1,2}</p> <table border="1"> <tr> <td>Manufacturer^{1,2}</td> <td>STM or compatible^{1,2}</td> </tr> <tr> <td>Connector Model Number (male)^{1,2}</td> <td>P24021P6 or compatible^{1,2}</td> </tr> <tr> <td>Mating Connector Model Number (female)^{1,2}</td> <td>JST / SM06B-SHLK-GTF(HF) or compatible^{1,2}</td> </tr> </table> <table border="1"> <thead> <tr> <th>Pin #^{1,2}</th> <th>Symbol^{1,2}</th> <th>Pin Description^{1,2}</th> <th>Cable color^{1,2}</th> </tr> </thead> <tbody> <tr> <td>1^{1,2}</td> <td>NC^{1,2}</td> <td>---</td> <td>No cable^{1,2}</td> </tr> <tr> <td>2^{1,2}</td> <td>NC^{1,2}</td> <td>---</td> <td>No cable^{1,2}</td> </tr> <tr> <td>3^{1,2}</td> <td>AN1^{1,2}</td> <td>Channel 1 LED anode^{1,2}</td> <td>Red^{1,2}</td> </tr> <tr> <td>4^{1,2}</td> <td>CA1^{1,2}</td> <td>Channel 1 LED cathode^{1,2}</td> <td>White^{1,2}</td> </tr> <tr> <td>5^{1,2}</td> <td>NC^{1,2}</td> <td>---</td> <td>No cable^{1,2}</td> </tr> <tr> <td>6^{1,2}</td> <td>NC^{1,2}</td> <td>---</td> <td>No cable^{1,2}</td> </tr> </tbody> </table>	Manufacturer ^{1,2}	STM or compatible ^{1,2}	Connector Model Number (male) ^{1,2}	P24021P6 or compatible ^{1,2}	Mating Connector Model Number (female) ^{1,2}	JST / SM06B-SHLK-GTF(HF) or compatible ^{1,2}	Pin # ^{1,2}	Symbol ^{1,2}	Pin Description ^{1,2}	Cable color ^{1,2}	1 ^{1,2}	NC ^{1,2}	---	No cable ^{1,2}	2 ^{1,2}	NC ^{1,2}	---	No cable ^{1,2}	3 ^{1,2}	AN1 ^{1,2}	Channel 1 LED anode ^{1,2}	Red ^{1,2}	4 ^{1,2}	CA1 ^{1,2}	Channel 1 LED cathode ^{1,2}	White ^{1,2}	5 ^{1,2}	NC ^{1,2}	---	No cable ^{1,2}	6 ^{1,2}	NC ^{1,2}	---	No cable ^{1,2}																																																																																																																																																																							
Manufacturer ^{1,2}	STM or compatible ^{1,2}																																																																																																																																																																																																											
Connector Model Number (male) ^{1,2}	P24021P6 or compatible ^{1,2}																																																																																																																																																																																																											
Mating Connector Model Number (female) ^{1,2}	JST / SM06B-SHLK-GTF(HF) or compatible ^{1,2}																																																																																																																																																																																																											
Pin # ^{1,2}	Symbol ^{1,2}	Pin Description ^{1,2}	Cable color ^{1,2}																																																																																																																																																																																																									
1 ^{1,2}	NC ^{1,2}	---	No cable ^{1,2}																																																																																																																																																																																																									
2 ^{1,2}	NC ^{1,2}	---	No cable ^{1,2}																																																																																																																																																																																																									
3 ^{1,2}	AN1 ^{1,2}	Channel 1 LED anode ^{1,2}	Red ^{1,2}																																																																																																																																																																																																									
4 ^{1,2}	CA1 ^{1,2}	Channel 1 LED cathode ^{1,2}	White ^{1,2}																																																																																																																																																																																																									
5 ^{1,2}	NC ^{1,2}	---	No cable ^{1,2}																																																																																																																																																																																																									
6 ^{1,2}	NC ^{1,2}	---	No cable ^{1,2}																																																																																																																																																																																																									

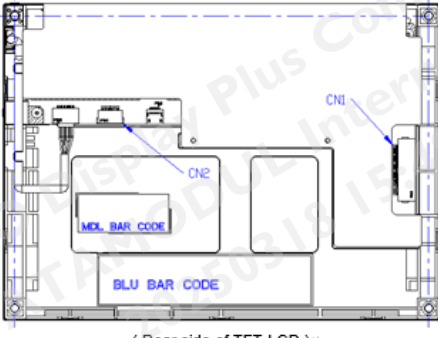
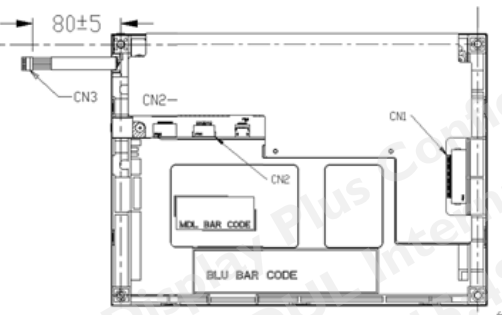
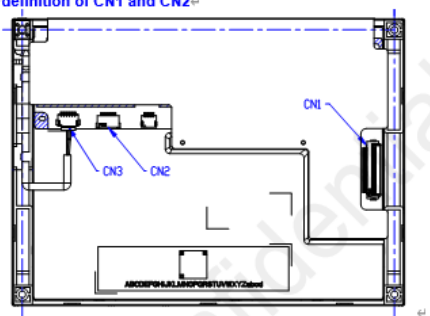
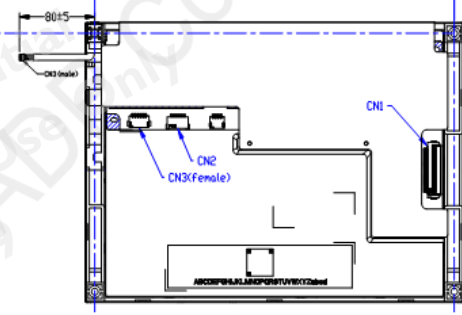
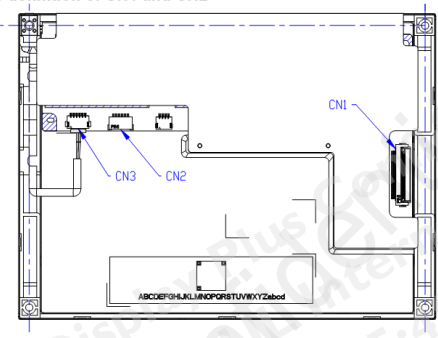
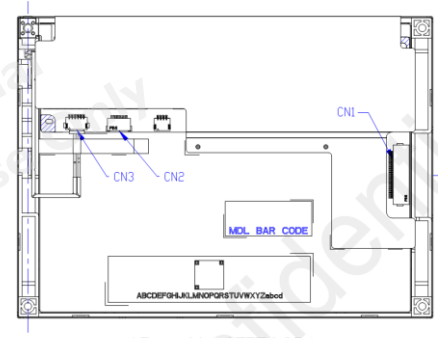
<p>21</p>	<p>7.3 Connector Illustration[Ⓔ] 7.3.1 PIN 1 definition of CN1 and CN2[Ⓔ]</p>  <p>(Rear side of TFT-LCD)[Ⓔ]</p> <p>7.3.2 PIN 1 definition of CN3[Ⓔ]</p>  <p>(Rear side of TFT-LCD)[Ⓔ]</p>	<p>Add CN3 mark</p> <p>7.4 Connector Illustration[Ⓔ] 7.4.1 PIN 1 definition of CN1 and CN2[Ⓔ]</p>  <p>(Rear side of TFT-LCD)[Ⓔ]</p> <p>7.4.2 PIN 1 definition of CN3[Ⓔ]</p>  <p>(Rear side of TFT-LCD)[Ⓔ]</p>																																																																																																																																																																																																				
<p>22</p>	<p>NOTE: 1.CN1 I/F CONNECTOR IS 089H33-000100-G2-R (STARCONN) 2.LED DRIVER CONNECTOR IS SMO6B-SRKHS(LF)XSNX(JST) 3.TOLERANCE IS ±0.5 IF NOT SPECIFIED.</p>	<p>Update Drawing X1 and change CN2 type</p> <p>NOTE: 1.CN1 I/F CONNECTOR IS 089H33-000100-G2-R (STARCONN) 2.LED DRIVER CONNECTOR IS CII106MIHR0-NH (CvILux) ⚠ 3.TOLERANCE IS ±0.5 IF NOT SPECIFIED.</p>																																																																																																																																																																																																				
<p>25</p>	<p>11.4 National Test Lab Requirement[Ⓔ] The display module will satisfy all requirements for compliance to:[Ⓔ] UL 60950-1, Second Edition U.S.A. Information Technology Equipment</p>	<p>11.4 National Test Lab Requirement[Ⓔ] The display module will satisfy all requirements for compliance to: IEC/UL 62368-1[Ⓔ]</p>																																																																																																																																																																																																				
<p>0.2 2024/11/05</p>	<p>7</p> <table border="1" data-bbox="422 1232 941 1276"> <tr> <td>Typical Power Consumption[Ⓔ]</td> <td>[Watt][Ⓔ]</td> <td>1.42 typ.[Ⓔ] @ All white pattern, Full Load and VLED=12V[Ⓔ]</td> </tr> </table>	Typical Power Consumption [Ⓔ]	[Watt] [Ⓔ]	1.42 typ. [Ⓔ] @ All white pattern, Full Load and VLED=12V [Ⓔ]	<p>Lower the power consumption</p> <table border="1" data-bbox="957 1232 1484 1276"> <tr> <td>Typical Power Consumption[Ⓔ]</td> <td>[Watt][Ⓔ]</td> <td>1.04 typ.[Ⓔ] @ All white pattern, Full Load and VLED=12V[Ⓔ]</td> </tr> </table>	Typical Power Consumption [Ⓔ]	[Watt] [Ⓔ]	1.04 typ. [Ⓔ] @ All white pattern, Full Load and VLED=12V [Ⓔ]																																																																																																																																																																																														
Typical Power Consumption [Ⓔ]	[Watt] [Ⓔ]	1.42 typ. [Ⓔ] @ All white pattern, Full Load and VLED=12V [Ⓔ]																																																																																																																																																																																																				
Typical Power Consumption [Ⓔ]	[Watt] [Ⓔ]	1.04 typ. [Ⓔ] @ All white pattern, Full Load and VLED=12V [Ⓔ]																																																																																																																																																																																																				
<p>14</p>	<p>5.2 Backlight Unit[Ⓔ] 5.2.1 Parameter guideline for LED[Ⓔ] Following characteristics are measured under stable condition using a LED driving board at 25°C (Room Temperature).[Ⓔ]</p> <table border="1" data-bbox="422 1377 941 1657"> <thead> <tr> <th>Symbol[Ⓔ]</th> <th>Parameter[Ⓔ]</th> <th>Min[Ⓔ]</th> <th>Typ[Ⓔ]</th> <th>Max[Ⓔ]</th> <th>Units[Ⓔ]</th> <th>Remark[Ⓔ]</th> </tr> </thead> <tbody> <tr> <td>VLED[Ⓔ]</td> <td>Input Voltage[Ⓔ]</td> <td>9[Ⓔ]</td> <td>12[Ⓔ]</td> <td>20[Ⓔ]</td> <td>Volt[Ⓔ]</td> <td></td> </tr> <tr> <td>ILED[Ⓔ]</td> <td>Input Current[Ⓔ]</td> <td></td> <td>0.1[Ⓔ]</td> <td>0.11[Ⓔ]</td> <td>A[Ⓔ]</td> <td>VLED = 12V, D_{FWM} = 100%[Ⓔ]</td> </tr> <tr> <td>PLED[Ⓔ]</td> <td>Power Consumption[Ⓔ]</td> <td></td> <td>1.33[Ⓔ]</td> <td>1.39[Ⓔ]</td> <td>W[Ⓔ]</td> <td>VLED = 12V, D_{FWM} = 100%[Ⓔ]</td> </tr> <tr> <td>InrushLED[Ⓔ]</td> <td>Inrush Current[Ⓔ]</td> <td></td> <td></td> <td>1.5[Ⓔ]</td> <td>A[Ⓔ]</td> <td>VLED = 12V, D_{FWM} = 100%[Ⓔ]</td> </tr> <tr> <td>V_{FWM DIM}[Ⓔ]</td> <td>Dimming control Voltage High[Ⓔ]</td> <td>2.0[Ⓔ]</td> <td>3.3[Ⓔ]</td> <td>5[Ⓔ]</td> <td>Volt[Ⓔ]</td> <td></td> </tr> <tr> <td></td> <td>Dimming control Voltage Low[Ⓔ]</td> <td></td> <td>0.15[Ⓔ]</td> <td></td> <td>Volt[Ⓔ]</td> <td>Note 1, 2[Ⓔ]</td> </tr> <tr> <td>F_{FWM}[Ⓔ]</td> <td>Dimming Frequency[Ⓔ]</td> <td>200[Ⓔ]</td> <td></td> <td>25K[Ⓔ]</td> <td>Hz[Ⓔ]</td> <td></td> </tr> <tr> <td>D_{FWM}[Ⓔ]</td> <td>Dimming duty cycle[Ⓔ]</td> <td>1[Ⓔ]</td> <td></td> <td>100[Ⓔ]</td> <td>%[Ⓔ]</td> <td></td> </tr> <tr> <td>VLED ON/OFF[Ⓔ]</td> <td>On Control Voltage[Ⓔ]</td> <td>2[Ⓔ]</td> <td>3.3[Ⓔ]</td> <td>5[Ⓔ]</td> <td>Volt[Ⓔ]</td> <td>Note 3, 4[Ⓔ]</td> </tr> <tr> <td></td> <td>Off Control Voltage[Ⓔ]</td> <td></td> <td>0.6[Ⓔ]</td> <td></td> <td>Volt[Ⓔ]</td> <td></td> </tr> <tr> <td>I_F[Ⓔ]</td> <td>LED Forward Current[Ⓔ]</td> <td></td> <td>50[Ⓔ]</td> <td></td> <td>mA[Ⓔ]</td> <td>T_a = 25°C[Ⓔ]</td> </tr> <tr> <td>V_F[Ⓔ]</td> <td>LED Forward Voltage[Ⓔ]</td> <td>22.4[Ⓔ]</td> <td>23.6[Ⓔ]</td> <td>24.8[Ⓔ]</td> <td>Volt[Ⓔ]</td> <td>I_F = 50mA, T_a = 25°C[Ⓔ]</td> </tr> <tr> <td>Operating Life[Ⓔ]</td> <td></td> <td>70,000[Ⓔ]</td> <td></td> <td></td> <td>Hrs[Ⓔ]</td> <td>Note 5, 6, 7[Ⓔ]</td> </tr> </tbody> </table>	Symbol [Ⓔ]	Parameter [Ⓔ]	Min [Ⓔ]	Typ [Ⓔ]	Max [Ⓔ]	Units [Ⓔ]	Remark [Ⓔ]	VLED [Ⓔ]	Input Voltage [Ⓔ]	9 [Ⓔ]	12 [Ⓔ]	20 [Ⓔ]	Volt [Ⓔ]		ILED [Ⓔ]	Input Current [Ⓔ]		0.1 [Ⓔ]	0.11 [Ⓔ]	A [Ⓔ]	VLED = 12V, D _{FWM} = 100% [Ⓔ]	PLED [Ⓔ]	Power Consumption [Ⓔ]		1.33 [Ⓔ]	1.39 [Ⓔ]	W [Ⓔ]	VLED = 12V, D _{FWM} = 100% [Ⓔ]	InrushLED [Ⓔ]	Inrush Current [Ⓔ]			1.5 [Ⓔ]	A [Ⓔ]	VLED = 12V, D _{FWM} = 100% [Ⓔ]	V _{FWM DIM} [Ⓔ]	Dimming control Voltage High [Ⓔ]	2.0 [Ⓔ]	3.3 [Ⓔ]	5 [Ⓔ]	Volt [Ⓔ]			Dimming control Voltage Low [Ⓔ]		0.15 [Ⓔ]		Volt [Ⓔ]	Note 1, 2 [Ⓔ]	F _{FWM} [Ⓔ]	Dimming Frequency [Ⓔ]	200 [Ⓔ]		25K [Ⓔ]	Hz [Ⓔ]		D _{FWM} [Ⓔ]	Dimming duty cycle [Ⓔ]	1 [Ⓔ]		100 [Ⓔ]	% [Ⓔ]		VLED ON/OFF [Ⓔ]	On Control Voltage [Ⓔ]	2 [Ⓔ]	3.3 [Ⓔ]	5 [Ⓔ]	Volt [Ⓔ]	Note 3, 4 [Ⓔ]		Off Control Voltage [Ⓔ]		0.6 [Ⓔ]		Volt [Ⓔ]		I _F [Ⓔ]	LED Forward Current [Ⓔ]		50 [Ⓔ]		mA [Ⓔ]	T _a = 25°C [Ⓔ]	V _F [Ⓔ]	LED Forward Voltage [Ⓔ]	22.4 [Ⓔ]	23.6 [Ⓔ]	24.8 [Ⓔ]	Volt [Ⓔ]	I _F = 50mA, T _a = 25°C [Ⓔ]	Operating Life [Ⓔ]		70,000 [Ⓔ]			Hrs [Ⓔ]	Note 5, 6, 7 [Ⓔ]	<p>Lower the LED current</p> <p>5.2 Backlight Unit[Ⓔ] 5.2.1 Parameter guideline for LED[Ⓔ] Following characteristics are measured under stable condition using a LED driving board at 25°C (Room Temperature).[Ⓔ]</p> <table border="1" data-bbox="957 1377 1484 1657"> <thead> <tr> <th>Symbol[Ⓔ]</th> <th>Parameter[Ⓔ]</th> <th>Min[Ⓔ]</th> <th>Typ[Ⓔ]</th> <th>Max[Ⓔ]</th> <th>Units[Ⓔ]</th> <th>Remark[Ⓔ]</th> </tr> </thead> <tbody> <tr> <td>VLED[Ⓔ]</td> <td>Input Voltage[Ⓔ]</td> <td>9[Ⓔ]</td> <td>12[Ⓔ]</td> <td>20[Ⓔ]</td> <td>Volt[Ⓔ]</td> <td></td> </tr> <tr> <td>ILED[Ⓔ]</td> <td>Input Current[Ⓔ]</td> <td></td> <td>0.079[Ⓔ]</td> <td>0.08[Ⓔ]</td> <td>A[Ⓔ]</td> <td>VLED = 12V, D_{FWM} = 100%[Ⓔ]</td> </tr> <tr> <td>PLED[Ⓔ]</td> <td>Power Consumption[Ⓔ]</td> <td></td> <td>0.95[Ⓔ]</td> <td>1.00[Ⓔ]</td> <td>W[Ⓔ]</td> <td>VLED = 12V, D_{FWM} = 100%[Ⓔ]</td> </tr> <tr> <td>InrushLED[Ⓔ]</td> <td>Inrush Current[Ⓔ]</td> <td></td> <td></td> <td>1.5[Ⓔ]</td> <td>A[Ⓔ]</td> <td>VLED = 12V, D_{FWM} = 100%[Ⓔ]</td> </tr> <tr> <td>V_{FWM DIM}[Ⓔ]</td> <td>Dimming control Voltage High[Ⓔ]</td> <td>2.0[Ⓔ]</td> <td>3.3[Ⓔ]</td> <td>5[Ⓔ]</td> <td>Volt[Ⓔ]</td> <td></td> </tr> <tr> <td></td> <td>Dimming control Voltage Low[Ⓔ]</td> <td></td> <td>0.15[Ⓔ]</td> <td></td> <td>Volt[Ⓔ]</td> <td>Note 1, 2[Ⓔ]</td> </tr> <tr> <td>F_{FWM}[Ⓔ]</td> <td>Dimming Frequency[Ⓔ]</td> <td>200[Ⓔ]</td> <td></td> <td>25K[Ⓔ]</td> <td>Hz[Ⓔ]</td> <td></td> </tr> <tr> <td>D_{FWM}[Ⓔ]</td> <td>Dimming duty cycle[Ⓔ]</td> <td>1[Ⓔ]</td> <td></td> <td>100[Ⓔ]</td> <td>%[Ⓔ]</td> <td></td> </tr> <tr> <td>VLED ON/OFF[Ⓔ]</td> <td>On Control Voltage[Ⓔ]</td> <td>2[Ⓔ]</td> <td>3.3[Ⓔ]</td> <td>5[Ⓔ]</td> <td>Volt[Ⓔ]</td> <td>Note 3, 4[Ⓔ]</td> </tr> <tr> <td></td> <td>Off Control Voltage[Ⓔ]</td> <td></td> <td>0.6[Ⓔ]</td> <td></td> <td>Volt[Ⓔ]</td> <td></td> </tr> <tr> <td>I_F[Ⓔ]</td> <td>LED Forward Current[Ⓔ]</td> <td></td> <td>36[Ⓔ]</td> <td></td> <td>mA[Ⓔ]</td> <td>T_a = 25°C[Ⓔ]</td> </tr> <tr> <td>V_F[Ⓔ]</td> <td>LED Forward Voltage[Ⓔ]</td> <td>22.4[Ⓔ]</td> <td>23.6[Ⓔ]</td> <td>24.8[Ⓔ]</td> <td>Volt[Ⓔ]</td> <td>I_F = 36mA, T_a = 25°C[Ⓔ]</td> </tr> <tr> <td>Operating Life[Ⓔ]</td> <td></td> <td>70,000[Ⓔ]</td> <td></td> <td></td> <td>Hrs[Ⓔ]</td> <td>Note 5, 6, 7[Ⓔ]</td> </tr> </tbody> </table>	Symbol [Ⓔ]	Parameter [Ⓔ]	Min [Ⓔ]	Typ [Ⓔ]	Max [Ⓔ]	Units [Ⓔ]	Remark [Ⓔ]	VLED [Ⓔ]	Input Voltage [Ⓔ]	9 [Ⓔ]	12 [Ⓔ]	20 [Ⓔ]	Volt [Ⓔ]		ILED [Ⓔ]	Input Current [Ⓔ]		0.079 [Ⓔ]	0.08 [Ⓔ]	A [Ⓔ]	VLED = 12V, D _{FWM} = 100% [Ⓔ]	PLED [Ⓔ]	Power Consumption [Ⓔ]		0.95 [Ⓔ]	1.00 [Ⓔ]	W [Ⓔ]	VLED = 12V, D _{FWM} = 100% [Ⓔ]	InrushLED [Ⓔ]	Inrush Current [Ⓔ]			1.5 [Ⓔ]	A [Ⓔ]	VLED = 12V, D _{FWM} = 100% [Ⓔ]	V _{FWM DIM} [Ⓔ]	Dimming control Voltage High [Ⓔ]	2.0 [Ⓔ]	3.3 [Ⓔ]	5 [Ⓔ]	Volt [Ⓔ]			Dimming control Voltage Low [Ⓔ]		0.15 [Ⓔ]		Volt [Ⓔ]	Note 1, 2 [Ⓔ]	F _{FWM} [Ⓔ]	Dimming Frequency [Ⓔ]	200 [Ⓔ]		25K [Ⓔ]	Hz [Ⓔ]		D _{FWM} [Ⓔ]	Dimming duty cycle [Ⓔ]	1 [Ⓔ]		100 [Ⓔ]	% [Ⓔ]		VLED ON/OFF [Ⓔ]	On Control Voltage [Ⓔ]	2 [Ⓔ]	3.3 [Ⓔ]	5 [Ⓔ]	Volt [Ⓔ]	Note 3, 4 [Ⓔ]		Off Control Voltage [Ⓔ]		0.6 [Ⓔ]		Volt [Ⓔ]		I _F [Ⓔ]	LED Forward Current [Ⓔ]		36 [Ⓔ]		mA [Ⓔ]	T _a = 25°C [Ⓔ]	V _F [Ⓔ]	LED Forward Voltage [Ⓔ]	22.4 [Ⓔ]	23.6 [Ⓔ]	24.8 [Ⓔ]	Volt [Ⓔ]	I _F = 36mA, T _a = 25°C [Ⓔ]	Operating Life [Ⓔ]		70,000 [Ⓔ]			Hrs [Ⓔ]	Note 5, 6, 7 [Ⓔ]
Symbol [Ⓔ]	Parameter [Ⓔ]	Min [Ⓔ]	Typ [Ⓔ]	Max [Ⓔ]	Units [Ⓔ]	Remark [Ⓔ]																																																																																																																																																																																																
VLED [Ⓔ]	Input Voltage [Ⓔ]	9 [Ⓔ]	12 [Ⓔ]	20 [Ⓔ]	Volt [Ⓔ]																																																																																																																																																																																																	
ILED [Ⓔ]	Input Current [Ⓔ]		0.1 [Ⓔ]	0.11 [Ⓔ]	A [Ⓔ]	VLED = 12V, D _{FWM} = 100% [Ⓔ]																																																																																																																																																																																																
PLED [Ⓔ]	Power Consumption [Ⓔ]		1.33 [Ⓔ]	1.39 [Ⓔ]	W [Ⓔ]	VLED = 12V, D _{FWM} = 100% [Ⓔ]																																																																																																																																																																																																
InrushLED [Ⓔ]	Inrush Current [Ⓔ]			1.5 [Ⓔ]	A [Ⓔ]	VLED = 12V, D _{FWM} = 100% [Ⓔ]																																																																																																																																																																																																
V _{FWM DIM} [Ⓔ]	Dimming control Voltage High [Ⓔ]	2.0 [Ⓔ]	3.3 [Ⓔ]	5 [Ⓔ]	Volt [Ⓔ]																																																																																																																																																																																																	
	Dimming control Voltage Low [Ⓔ]		0.15 [Ⓔ]		Volt [Ⓔ]	Note 1, 2 [Ⓔ]																																																																																																																																																																																																
F _{FWM} [Ⓔ]	Dimming Frequency [Ⓔ]	200 [Ⓔ]		25K [Ⓔ]	Hz [Ⓔ]																																																																																																																																																																																																	
D _{FWM} [Ⓔ]	Dimming duty cycle [Ⓔ]	1 [Ⓔ]		100 [Ⓔ]	% [Ⓔ]																																																																																																																																																																																																	
VLED ON/OFF [Ⓔ]	On Control Voltage [Ⓔ]	2 [Ⓔ]	3.3 [Ⓔ]	5 [Ⓔ]	Volt [Ⓔ]	Note 3, 4 [Ⓔ]																																																																																																																																																																																																
	Off Control Voltage [Ⓔ]		0.6 [Ⓔ]		Volt [Ⓔ]																																																																																																																																																																																																	
I _F [Ⓔ]	LED Forward Current [Ⓔ]		50 [Ⓔ]		mA [Ⓔ]	T _a = 25°C [Ⓔ]																																																																																																																																																																																																
V _F [Ⓔ]	LED Forward Voltage [Ⓔ]	22.4 [Ⓔ]	23.6 [Ⓔ]	24.8 [Ⓔ]	Volt [Ⓔ]	I _F = 50mA, T _a = 25°C [Ⓔ]																																																																																																																																																																																																
Operating Life [Ⓔ]		70,000 [Ⓔ]			Hrs [Ⓔ]	Note 5, 6, 7 [Ⓔ]																																																																																																																																																																																																
Symbol [Ⓔ]	Parameter [Ⓔ]	Min [Ⓔ]	Typ [Ⓔ]	Max [Ⓔ]	Units [Ⓔ]	Remark [Ⓔ]																																																																																																																																																																																																
VLED [Ⓔ]	Input Voltage [Ⓔ]	9 [Ⓔ]	12 [Ⓔ]	20 [Ⓔ]	Volt [Ⓔ]																																																																																																																																																																																																	
ILED [Ⓔ]	Input Current [Ⓔ]		0.079 [Ⓔ]	0.08 [Ⓔ]	A [Ⓔ]	VLED = 12V, D _{FWM} = 100% [Ⓔ]																																																																																																																																																																																																
PLED [Ⓔ]	Power Consumption [Ⓔ]		0.95 [Ⓔ]	1.00 [Ⓔ]	W [Ⓔ]	VLED = 12V, D _{FWM} = 100% [Ⓔ]																																																																																																																																																																																																
InrushLED [Ⓔ]	Inrush Current [Ⓔ]			1.5 [Ⓔ]	A [Ⓔ]	VLED = 12V, D _{FWM} = 100% [Ⓔ]																																																																																																																																																																																																
V _{FWM DIM} [Ⓔ]	Dimming control Voltage High [Ⓔ]	2.0 [Ⓔ]	3.3 [Ⓔ]	5 [Ⓔ]	Volt [Ⓔ]																																																																																																																																																																																																	
	Dimming control Voltage Low [Ⓔ]		0.15 [Ⓔ]		Volt [Ⓔ]	Note 1, 2 [Ⓔ]																																																																																																																																																																																																
F _{FWM} [Ⓔ]	Dimming Frequency [Ⓔ]	200 [Ⓔ]		25K [Ⓔ]	Hz [Ⓔ]																																																																																																																																																																																																	
D _{FWM} [Ⓔ]	Dimming duty cycle [Ⓔ]	1 [Ⓔ]		100 [Ⓔ]	% [Ⓔ]																																																																																																																																																																																																	
VLED ON/OFF [Ⓔ]	On Control Voltage [Ⓔ]	2 [Ⓔ]	3.3 [Ⓔ]	5 [Ⓔ]	Volt [Ⓔ]	Note 3, 4 [Ⓔ]																																																																																																																																																																																																
	Off Control Voltage [Ⓔ]		0.6 [Ⓔ]		Volt [Ⓔ]																																																																																																																																																																																																	
I _F [Ⓔ]	LED Forward Current [Ⓔ]		36 [Ⓔ]		mA [Ⓔ]	T _a = 25°C [Ⓔ]																																																																																																																																																																																																
V _F [Ⓔ]	LED Forward Voltage [Ⓔ]	22.4 [Ⓔ]	23.6 [Ⓔ]	24.8 [Ⓔ]	Volt [Ⓔ]	I _F = 36mA, T _a = 25°C [Ⓔ]																																																																																																																																																																																																
Operating Life [Ⓔ]		70,000 [Ⓔ]			Hrs [Ⓔ]	Note 5, 6, 7 [Ⓔ]																																																																																																																																																																																																
<p>22</p>	<p>7.4 Connector Illustration[Ⓔ] 7.4.1 PIN 1 definition of CN1 and CN2[Ⓔ]</p>  <p>(Rear side of TFT-LCD)[Ⓔ]</p>	<p>7.4 Connector Illustration[Ⓔ] 7.4.1 PIN 1 definition of CN1 and CN2[Ⓔ]</p>  <p>(Rear side of TFT-LCD)[Ⓔ]</p>																																																																																																																																																																																																				

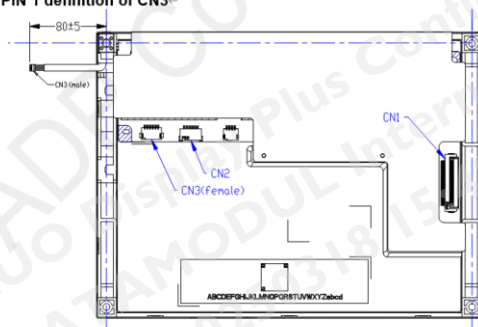
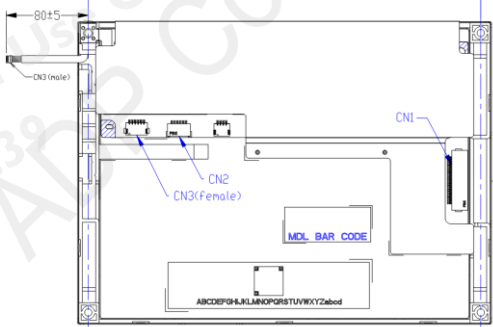
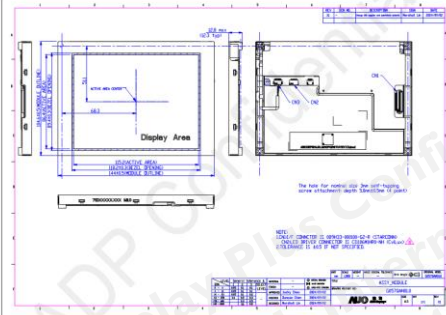
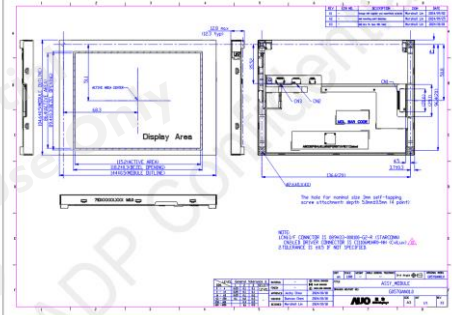
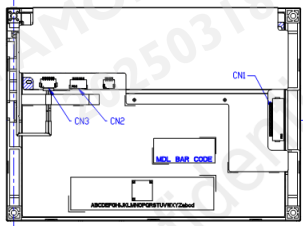
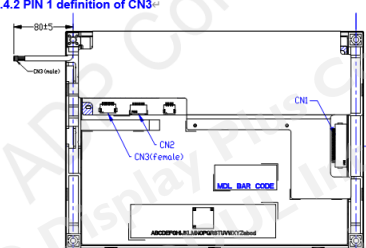
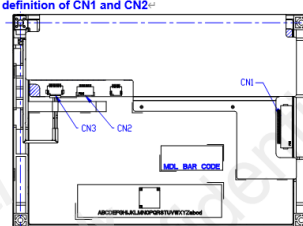
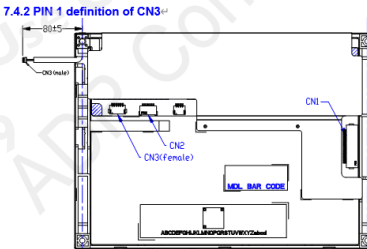
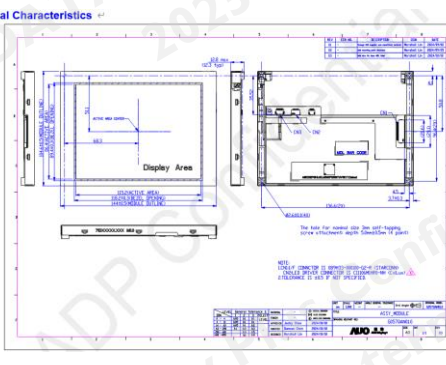
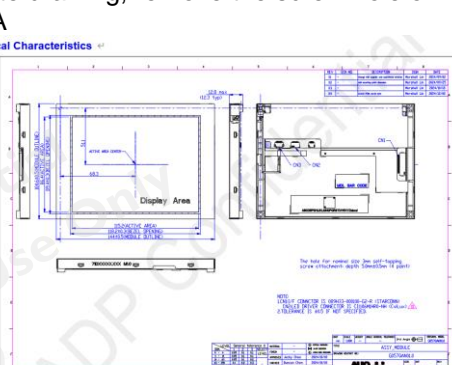
	22	<p>7.4.2 PIN 1 definition of CN3^①</p>  <p>(Rear side of TFT-LCD)^②</p>	<p>7.4.2 PIN 1 definition of CN3^①</p>  <p>(Rear side of TFT-LCD)^②</p>
	24	<p>9. Mechanical Characteristics^①</p> 	<p>9. Mechanical Characteristics^①</p> 
0.3 2025/12/02	23	<p>7.4 Connector Illustration^① 7.4.1 PIN 1 definition of CN1 and CN2^②</p>  <p>(Rear side of TFT-LCD)^②</p> <p>7.4.2 PIN 1 definition of CN3^①</p>  <p>(Rear side of TFT-LCD)^②</p>	<p>Update the drawings, remove the screw hole on PCBA</p> <p>7.4 Connector Illustration^① 7.4.1 PIN 1 definition of CN1 and CN2^②</p>  <p>(Rear side of TFT-LCD)^②</p> <p>7.4.2 PIN 1 definition of CN3^①</p>  <p>(Rear side of TFT-LCD)^②</p>
	25	<p>9. Mechanical Characteristics^①</p> 	<p>Update drawing, remove the screw hole on PCBA</p> <p>9. Mechanical Characteristics^①</p> 
0.4 2025/03/12	8	<p>Typical Power Consumption^① [Watt]^② 1.04 typ.^③ ③ All white pattern, Full Load and VLED=12V^④</p>	<p>Typical Power Consumption^① [Watt]^② 1.04 typ. (LCD: 0.09W / LED BLU: 0.95W)^③ ③ All white pattern, Full Load and VDD=3.3V - VLED=12V^④</p>

9	Color / Chromaticity Coordinates (CIE 1931)	<table border="1"> <tr><td>Red x</td><td>TBD</td></tr> <tr><td>Red y</td><td>TBD</td></tr> <tr><td>Green x</td><td>TBD</td></tr> <tr><td>Green y</td><td>TBD</td></tr> <tr><td>Blue x</td><td>TBD</td></tr> <tr><td>Blue y</td><td>TBD</td></tr> </table>	Red x	TBD	Red y	TBD	Green x	TBD	Green y	TBD	Blue x	TBD	Blue y	TBD	<table border="1"> <tr><td>Red x</td><td>0.551</td><td>0.601</td><td>0.651</td></tr> <tr><td>Red y</td><td>0.300</td><td>0.350</td><td>0.400</td></tr> <tr><td>Green x</td><td>0.275</td><td>0.325</td><td>0.375</td></tr> <tr><td>Green y</td><td>0.533</td><td>0.583</td><td>0.633</td></tr> <tr><td>Blue x</td><td>0.100</td><td>0.150</td><td>0.200</td></tr> <tr><td>Blue y</td><td>0.089</td><td>0.139</td><td>0.189</td></tr> </table>	Red x	0.551	0.601	0.651	Red y	0.300	0.350	0.400	Green x	0.275	0.325	0.375	Green y	0.533	0.583	0.633	Blue x	0.100	0.150	0.200	Blue y	0.089	0.139	0.189																																																																																																														
	Red x	TBD																																																																																																																																																			
Red y	TBD																																																																																																																																																				
Green x	TBD																																																																																																																																																				
Green y	TBD																																																																																																																																																				
Blue x	TBD																																																																																																																																																				
Blue y	TBD																																																																																																																																																				
Red x	0.551	0.601	0.651																																																																																																																																																		
Red y	0.300	0.350	0.400																																																																																																																																																		
Green x	0.275	0.325	0.375																																																																																																																																																		
Green y	0.533	0.583	0.633																																																																																																																																																		
Blue x	0.100	0.150	0.200																																																																																																																																																		
Blue y	0.089	0.139	0.189																																																																																																																																																		
15	<table border="1"> <tr><td>I_{LED}</td><td>Input Current</td><td>0.079</td><td>0.08</td><td>A</td><td>V_{LED} = 12V, D_{PWM} = 100%</td></tr> <tr><td>P_{LED}</td><td>Power Consumption</td><td>0.95</td><td>1.00</td><td>W</td><td>V_{LED} = 12V, D_{PWM} = 100%</td></tr> </table>	I _{LED}	Input Current	0.079	0.08	A	V _{LED} = 12V, D _{PWM} = 100%	P _{LED}	Power Consumption	0.95	1.00	W	V _{LED} = 12V, D _{PWM} = 100%	<table border="1"> <tr><td>I_{LED}</td><td>Input Current</td><td>0.076</td><td>0.079</td><td>A</td><td>V_{LED} = 12V, D_{PWM} = 100%</td></tr> <tr><td>P_{LED}</td><td>Power Consumption</td><td>0.91</td><td>0.95</td><td>W</td><td>V_{LED} = 12V, D_{PWM} = 100%</td></tr> </table>	I _{LED}	Input Current	0.076	0.079	A	V _{LED} = 12V, D _{PWM} = 100%	P _{LED}	Power Consumption	0.91	0.95	W	V _{LED} = 12V, D _{PWM} = 100%																																																																																																																											
	I _{LED}	Input Current	0.079	0.08	A	V _{LED} = 12V, D _{PWM} = 100%																																																																																																																																															
	P _{LED}	Power Consumption	0.95	1.00	W	V _{LED} = 12V, D _{PWM} = 100%																																																																																																																																															
I _{LED}	Input Current	0.076	0.079	A	V _{LED} = 12V, D _{PWM} = 100%																																																																																																																																																
P _{LED}	Power Consumption	0.91	0.95	W	V _{LED} = 12V, D _{PWM} = 100%																																																																																																																																																
<table border="1"> <tr><td>I_F</td><td>LED Forward Current</td><td>36</td><td>mA</td><td>T_a = 25°C</td></tr> <tr><td>V_F</td><td>LED Forward Voltage</td><td>22.4</td><td>23.6</td><td>24.8</td><td>Volt</td><td>I_F = 36mA, T_a = 25°C</td></tr> </table>	I _F	LED Forward Current	36	mA	T _a = 25°C	V _F	LED Forward Voltage	22.4	23.6	24.8	Volt	I _F = 36mA, T _a = 25°C	<table border="1"> <tr><td>I_F</td><td>LED Forward Current</td><td>33</td><td>mA</td><td>T_a = 25°C</td></tr> <tr><td>V_F</td><td>LED Forward Voltage</td><td>22.4</td><td>23.6</td><td>24.8</td><td>Volt</td><td>I_F = 33mA, T_a = 25°C</td></tr> </table>	I _F	LED Forward Current	33	mA	T _a = 25°C	V _F	LED Forward Voltage	22.4	23.6	24.8	Volt	I _F = 33mA, T _a = 25°C																																																																																																																												
I _F	LED Forward Current	36	mA	T _a = 25°C																																																																																																																																																	
V _F	LED Forward Voltage	22.4	23.6	24.8	Volt	I _F = 36mA, T _a = 25°C																																																																																																																																															
I _F	LED Forward Current	33	mA	T _a = 25°C																																																																																																																																																	
V _F	LED Forward Voltage	22.4	23.6	24.8	Volt	I _F = 33mA, T _a = 25°C																																																																																																																																															
Note 7: The test condition is 36mA in 25°C room temperature.		Note 7: The test condition is 33mA in 25°C room temperature.																																																																																																																																																			
20	6.6 LED Backlight Unit Interface Signal Description	<table border="1"> <thead> <tr><th>Pin #</th><th>Symbol</th><th>Pin Description</th></tr> </thead> <tbody> <tr><td>1</td><td>V_{LED}</td><td>12V input</td></tr> <tr><td>2</td><td>V_{LED}</td><td>12V input</td></tr> <tr><td>3</td><td>GND</td><td>Ground</td></tr> <tr><td>4</td><td>GND</td><td>Ground</td></tr> <tr><td>5</td><td>PWM DIM</td><td>1~100% PWM dimming</td></tr> <tr><td>6</td><td>LED On/Off</td><td>0V-Off; 2-5V/NC-On</td></tr> </tbody> </table>	Pin #	Symbol	Pin Description	1	V _{LED}	12V input	2	V _{LED}	12V input	3	GND	Ground	4	GND	Ground	5	PWM DIM	1~100% PWM dimming	6	LED On/Off	0V-Off; 2-5V/NC-On	<table border="1"> <thead> <tr><th>Pin #</th><th>Symbol</th><th>Pin Description</th></tr> </thead> <tbody> <tr><td>1</td><td>V_{LED}</td><td>12V input</td></tr> <tr><td>2</td><td>V_{LED}</td><td>12V input</td></tr> <tr><td>3</td><td>GND</td><td>Ground</td></tr> <tr><td>4</td><td>GND</td><td>Ground</td></tr> <tr><td>5</td><td>PWM DIM</td><td>1~100% PWM dimming</td></tr> <tr><td>6</td><td>LED On/Off</td><td>0V-Off; 2-5V-On</td></tr> </tbody> </table>	Pin #	Symbol	Pin Description	1	V _{LED}	12V input	2	V _{LED}	12V input	3	GND	Ground	4	GND	Ground	5	PWM DIM	1~100% PWM dimming	6	LED On/Off	0V-Off; 2-5V-On																																																																																																								
	Pin #	Symbol	Pin Description																																																																																																																																																		
1	V _{LED}	12V input																																																																																																																																																			
2	V _{LED}	12V input																																																																																																																																																			
3	GND	Ground																																																																																																																																																			
4	GND	Ground																																																																																																																																																			
5	PWM DIM	1~100% PWM dimming																																																																																																																																																			
6	LED On/Off	0V-Off; 2-5V/NC-On																																																																																																																																																			
Pin #	Symbol	Pin Description																																																																																																																																																			
1	V _{LED}	12V input																																																																																																																																																			
2	V _{LED}	12V input																																																																																																																																																			
3	GND	Ground																																																																																																																																																			
4	GND	Ground																																																																																																																																																			
5	PWM DIM	1~100% PWM dimming																																																																																																																																																			
6	LED On/Off	0V-Off; 2-5V-On																																																																																																																																																			
21	Power ON/OFF sequence timing	<table border="1"> <thead> <tr><th rowspan="2">Parameter</th><th colspan="3">Value</th><th rowspan="2">Units</th></tr> <tr><th>Min.</th><th>Typ.</th><th>Max.</th></tr> </thead> <tbody> <tr><td>T1</td><td>0.5</td><td></td><td>10</td><td>[ms]</td></tr> <tr><td>T2</td><td>30</td><td>40</td><td>50</td><td>[ms]</td></tr> <tr><td>T3</td><td>200</td><td></td><td></td><td>[ms]</td></tr> <tr><td>T4</td><td>0.5</td><td></td><td>10</td><td>[ms]</td></tr> <tr><td>T5</td><td>10</td><td></td><td></td><td>[ms]</td></tr> <tr><td>T6</td><td>10</td><td></td><td></td><td>[ms]</td></tr> <tr><td>T7</td><td>0</td><td></td><td></td><td>[ms]</td></tr> <tr><td>T8</td><td>10</td><td></td><td></td><td>[ms]</td></tr> <tr><td>T9</td><td></td><td></td><td>10</td><td>[ms]</td></tr> <tr><td>T10</td><td>110</td><td></td><td></td><td>[ms]</td></tr> <tr><td>T11</td><td>0</td><td>16</td><td>50</td><td>[ms]</td></tr> <tr><td>T12</td><td></td><td></td><td>10</td><td>[ms]</td></tr> <tr><td>T13</td><td>1000</td><td></td><td></td><td>[ms]</td></tr> </tbody> </table>	Parameter	Value			Units	Min.	Typ.	Max.	T1	0.5		10	[ms]	T2	30	40	50	[ms]	T3	200			[ms]	T4	0.5		10	[ms]	T5	10			[ms]	T6	10			[ms]	T7	0			[ms]	T8	10			[ms]	T9			10	[ms]	T10	110			[ms]	T11	0	16	50	[ms]	T12			10	[ms]	T13	1000			[ms]	<table border="1"> <thead> <tr><th rowspan="2">Parameter</th><th colspan="3">Value</th><th rowspan="2">Units</th></tr> <tr><th>Min.</th><th>Typ.</th><th>Max.</th></tr> </thead> <tbody> <tr><td>T1</td><td>0.5</td><td></td><td>10</td><td>[ms]</td></tr> <tr><td>T2</td><td>30</td><td>40</td><td>50</td><td>[ms]</td></tr> <tr><td>T3</td><td>250</td><td></td><td></td><td>[ms]</td></tr> <tr><td>T4</td><td>0.5</td><td></td><td>10</td><td>[ms]</td></tr> <tr><td>T5</td><td>10</td><td></td><td></td><td>[ms]</td></tr> <tr><td>T6</td><td>10</td><td></td><td></td><td>[ms]</td></tr> <tr><td>T7</td><td>0</td><td></td><td></td><td>[ms]</td></tr> <tr><td>T8</td><td>10</td><td></td><td></td><td>[ms]</td></tr> <tr><td>T9</td><td></td><td></td><td>10</td><td>[ms]</td></tr> <tr><td>T10</td><td>110</td><td></td><td></td><td>[ms]</td></tr> <tr><td>T11</td><td>60</td><td>80</td><td>100</td><td>[ms]</td></tr> <tr><td>T12</td><td></td><td></td><td>10</td><td>[ms]</td></tr> <tr><td>T13</td><td>1000</td><td></td><td></td><td>[ms]</td></tr> </tbody> </table>	Parameter	Value			Units	Min.	Typ.	Max.	T1	0.5		10	[ms]	T2	30	40	50	[ms]	T3	250			[ms]	T4	0.5		10	[ms]	T5	10			[ms]	T6	10			[ms]	T7	0			[ms]	T8	10			[ms]	T9			10	[ms]	T10	110			[ms]	T11	60	80	100	[ms]	T12			10	[ms]	T13	1000			[ms]
	Parameter	Value			Units																																																																																																																																																
Min.		Typ.	Max.																																																																																																																																																		
T1	0.5		10	[ms]																																																																																																																																																	
T2	30	40	50	[ms]																																																																																																																																																	
T3	200			[ms]																																																																																																																																																	
T4	0.5		10	[ms]																																																																																																																																																	
T5	10			[ms]																																																																																																																																																	
T6	10			[ms]																																																																																																																																																	
T7	0			[ms]																																																																																																																																																	
T8	10			[ms]																																																																																																																																																	
T9			10	[ms]																																																																																																																																																	
T10	110			[ms]																																																																																																																																																	
T11	0	16	50	[ms]																																																																																																																																																	
T12			10	[ms]																																																																																																																																																	
T13	1000			[ms]																																																																																																																																																	
Parameter	Value			Units																																																																																																																																																	
	Min.	Typ.	Max.																																																																																																																																																		
T1	0.5		10	[ms]																																																																																																																																																	
T2	30	40	50	[ms]																																																																																																																																																	
T3	250			[ms]																																																																																																																																																	
T4	0.5		10	[ms]																																																																																																																																																	
T5	10			[ms]																																																																																																																																																	
T6	10			[ms]																																																																																																																																																	
T7	0			[ms]																																																																																																																																																	
T8	10			[ms]																																																																																																																																																	
T9			10	[ms]																																																																																																																																																	
T10	110			[ms]																																																																																																																																																	
T11	60	80	100	[ms]																																																																																																																																																	
T12			10	[ms]																																																																																																																																																	
T13	1000			[ms]																																																																																																																																																	
22	7.1 TFT- LCD Signal (CN1): LCD Connector	<table border="1"> <tr><td>Manufacturer</td><td>Starconn</td></tr> <tr><td>Connector Model Number</td><td>089H33-000100-G2-R, compatible with MS2406P33M</td></tr> </table>	Manufacturer	Starconn	Connector Model Number	089H33-000100-G2-R, compatible with MS2406P33M	<table border="1"> <tr><td>Manufacturer</td><td>Starconn</td></tr> <tr><td>Connector Model Number</td><td>089H33-000100-G2-R</td></tr> </table>	Manufacturer	Starconn	Connector Model Number	089H33-000100-G2-R																																																																																																																																										
	Manufacturer	Starconn																																																																																																																																																			
Connector Model Number	089H33-000100-G2-R, compatible with MS2406P33M																																																																																																																																																				
Manufacturer	Starconn																																																																																																																																																				
Connector Model Number	089H33-000100-G2-R																																																																																																																																																				
	7.2 LED Backlight Unit (CN2): Backlight Connector	<table border="1"> <tr><td>Manufacturer</td><td>CivLux</td></tr> <tr><td>Connector Model Number (female)</td><td>C11106M1HR0-NH or compatible with SM06B-SRKS-G-TB</td></tr> <tr><td>Mating Connector Model Number (male)</td><td>JST SHR-06V-BKHF-B or compatible</td></tr> </table>	Manufacturer	CivLux	Connector Model Number (female)	C11106M1HR0-NH or compatible with SM06B-SRKS-G-TB	Mating Connector Model Number (male)	JST SHR-06V-BKHF-B or compatible	<table border="1"> <tr><td>Manufacturer</td><td>CivLux</td></tr> <tr><td>Connector Model Number (female)</td><td>C11106M1HR0-NH</td></tr> <tr><td>Mating Connector Model Number (male)</td><td>Housing: C11106S0000-NH, Contact: C1111011PPO or compatible</td></tr> </table>	Manufacturer	CivLux	Connector Model Number (female)	C11106M1HR0-NH	Mating Connector Model Number (male)	Housing: C11106S0000-NH, Contact: C1111011PPO or compatible																																																																																																																																						
	Manufacturer	CivLux																																																																																																																																																			
Connector Model Number (female)	C11106M1HR0-NH or compatible with SM06B-SRKS-G-TB																																																																																																																																																				
Mating Connector Model Number (male)	JST SHR-06V-BKHF-B or compatible																																																																																																																																																				
Manufacturer	CivLux																																																																																																																																																				
Connector Model Number (female)	C11106M1HR0-NH																																																																																																																																																				
Mating Connector Model Number (male)	Housing: C11106S0000-NH, Contact: C1111011PPO or compatible																																																																																																																																																				
	7.3 LED Light Bar Input (CN3): Light Bar Connector	<table border="1"> <tr><td>Manufacturer</td><td>STM or compatible</td></tr> <tr><td>Connector Model Number (male)</td><td>P24021P6 or compatible</td></tr> <tr><td>Mating Connector Model Number (female)</td><td>JST / SM06B-SHLK-GTF(HF) or compatible</td></tr> </table>	Manufacturer	STM or compatible	Connector Model Number (male)	P24021P6 or compatible	Mating Connector Model Number (female)	JST / SM06B-SHLK-GTF(HF) or compatible	<table border="1"> <tr><td>Manufacturer</td><td>JST</td></tr> <tr><td>Connector Model Number (female)</td><td>SM06B-SHLK-G-TF(HF)</td></tr> <tr><td>Mating Connector Model Number (male)</td><td>Housing: SHLP-06V-BK-B(HF), Contact: SSLH-003T-P0.2 or compatible</td></tr> </table>	Manufacturer	JST	Connector Model Number (female)	SM06B-SHLK-G-TF(HF)	Mating Connector Model Number (male)	Housing: SHLP-06V-BK-B(HF), Contact: SSLH-003T-P0.2 or compatible																																																																																																																																						
	Manufacturer	STM or compatible																																																																																																																																																			
Connector Model Number (male)	P24021P6 or compatible																																																																																																																																																				
Mating Connector Model Number (female)	JST / SM06B-SHLK-GTF(HF) or compatible																																																																																																																																																				
Manufacturer	JST																																																																																																																																																				
Connector Model Number (female)	SM06B-SHLK-G-TF(HF)																																																																																																																																																				
Mating Connector Model Number (male)	Housing: SHLP-06V-BK-B(HF), Contact: SSLH-003T-P0.2 or compatible																																																																																																																																																				

1. Operating Precautions

- 1) Since front polarizer is easily damaged, please be cautious and not to scratch it.
- 2) Be sure to turn off power supply when inserting or disconnecting from input connector.
- 3) Wipe off water drop immediately. Long contact with water may cause discoloration or spots.
- 4) When the panel surface is soiled, wipe it with absorbent cotton or soft cloth.
- 5) Since the panel is made of glass, it may be broken or cracked if dropped or bumped on hard surface.
- 6) Since CMOS LSI is used in this module, take care of static electricity and insure human earth when handling.
- 7) Do not open nor modify the module assembly.
- 8) Do not press the reflector sheet at the back of the module to any direction.
- 9) In case if a module has to be put back into the packing container slot after it was taken out from the container, do not press the center of the LED Reflector edge. Instead, press at the far ends of the LED Reflector edge softly. Otherwise the TFT Module may be damaged.
- 10) At the insertion or removal of the Signal Interface Connector, be sure not to rotate nor tilt the Interface Connector of the TFT Module.
- 11) TFT-LCD Module is not allowed to be twisted & bent even force is added on module in a very short time. Please design your display product well to avoid external force applying to module by end-user directly.
- 12) Small amount of materials without flammability grade are used in the TFT-LCD module. The TFT-LCD module should be supplied by power complied with requirements of Limited Power Source (IEC60950-1 or UL60950-1), or be applied exemption.
- 13) Severe temperature condition may result in different luminance, response time.
- 14) Continuous operating TFT-LCD Module under high temperature environment may accelerate LED light bar exhaustion and reduce luminance dramatically.
- 15) The data on this specification sheet is applicable when TFT-LCD module is placed in landscape position.
- 16) Continuous displaying fixed pattern may induce image sticking. It's recommended to use screen saver or moving content periodically if fixed pattern is displayed on the screen.

2. General Description

G057QAN01.0 is a Color Active Matrix Liquid Crystal Display composed of a TFT-LCD display, a driver circuit, and a backlight system. The screen format is intended to support QVGA (320(H) x 240(V)) screen and 262K (RGB 6-bits). All input signals are CMOS interface compatible.

G057QAN01.0 is designed for industrial display applications.

2.1 Display Characteristics

The following items are characteristics summary on the table under 25°C condition:

Items	Unit	Specifications
Screen Diagonal	[inch]	5.7
Active Area	[mm]	115.2(H) x 86.4(V)
Pixels H x V		320x3(RGB)x240
Pixel Pitch	[mm]	0.36 x 0.36
Pixel Arrangement		R.G.B. Vertical Stripe
Display Mode		AHVA mode, Normally Black
Nominal Input Voltage VDD	[Volt]	3.3 typ.
Typical Power Consumption	[Watt]	1.04 typ. (LCD: 0.09W / LED BLU: 0.95W) @ All white pattern, Full Load and VDD=3.3V、VLED=12V
Weight	[Grams]	150g (typ.), 165g (max.)
Physical Size	[mm]	144.0(H)x 104.6(V) x 12.3(D) (typ.)
Electrical Interface		CMOS 6-bit Parallel RGB
Surface Treatment		Anti-Glare, Hardness 3H
Support Color		262K colors
Temperature Range Operating Storage (Non-Operating)	[°C] [°C]	-30 to +85 (Panel surface temperature) -30 to +85
RoHS Compliance		RoHS Compliance
Light Bar Unit		LED

2.2 Optical Characteristics

The optical characteristics are measured under stable conditions at 25°C (Room Temperature):

Item	Unit	Conditions	Min.	Typ.	Max.	Remark
White Luminance	[cd/m ²]	V _{LED} =12V, D _{PWM} =100% (center point)	400	500	-	Note 1
Uniformity		5 Points			1.3	Note 1, 2, 3
Contrast Ratio			700	1000	-	Note 4
Response Time	[msec]	Rising	-	15	20	Note 5
	[msec]	Falling	-	10	15	
	[msec]	Raising + Falling	-	25	35	
Viewing Angle	[degree]	Horizontal (Right) CR = 10 (Left)	80	89	-	Note 6
	[degree]		80	89	-	
	[degree]	Vertical (Upper) CR = 10 (Lower)	80	89	-	
	[degree]		80	89	-	
Color / Chromaticity Coordinates (CIE 1931)		White x	0.263	0.313	0.363	
		White y	0.279	0.329	0.379	
		Red x	0.551	0.601	0.651	
		Red y	0.300	0.350	0.400	
		Green x	0.275	0.325	0.375	
		Green y	0.533	0.583	0.633	
		Blue x	0.100	0.150	0.200	
		Blue y	0.089	0.139	0.189	
Color Gamut	%			50		

Note 1: Measurement method

Equipment Pattern Generator, Power Supply, Digital Voltmeter, Luminance meter (SR_3 or equivalent)

Aperture 1° with 50cm viewing distance

Test Point Center

Environment < 1 lux

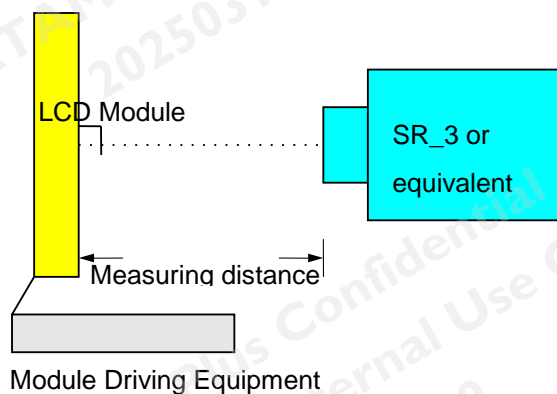

Note 2: Definition of 5 points position (Display active area: 115.2(H) x 86.4(V))

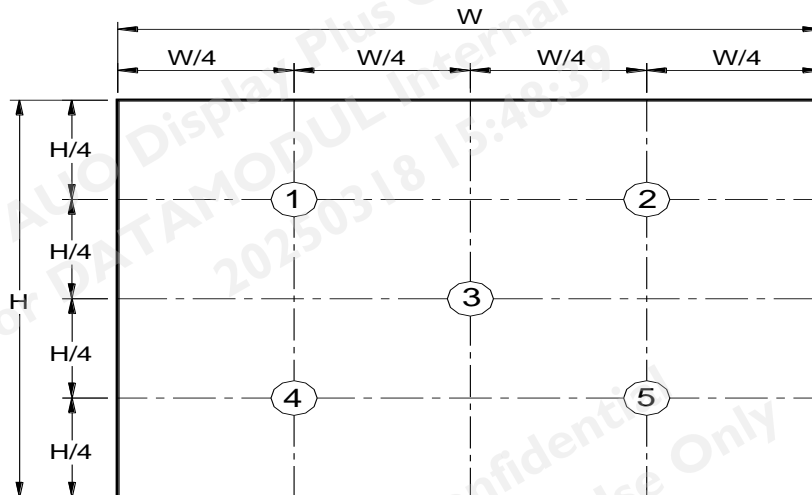

Note 3: The luminance uniformity of 5 points is defined by dividing the minimum luminance values by the maximum test point luminance

$$\text{Uniformity (5 points)} = \frac{\text{Minimum Luminance of 5 points}}{\text{Maximum Luminance of 5 points}}$$

Note 4 : Definition of contrast ratio (CR):

$$\text{Contrast ratio (CR)} = \frac{\text{Brightness on the "White" state}}{\text{Brightness on the "Black" state}}$$

Note 5: Definition of response time:

The output signals of photo detector are measured when the input signals are changed from "White" to "Black" (falling time) and from "Black" to "White" (rising time), respectively. The response time interval is between 10% and 90% of amplitudes. Please refer to the figure as below.

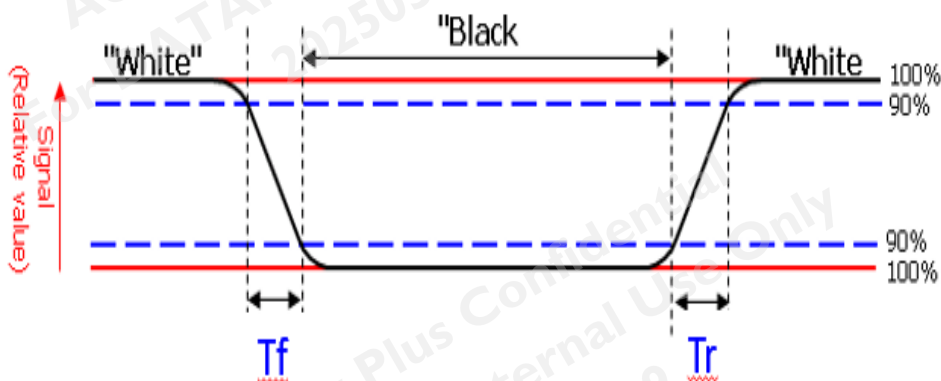

AUO Display+

Note 6: Definition of viewing angle

Viewing angle is the measurement of contrast ratio ≥ 10 , at the screen center, over a 180° horizontal and 180° vertical range (off-normal viewing angles). The 180° viewing angle range is broken down as below: 90° (θ) horizontal left and right, and 90° (Φ) vertical high (up) and low (down). The measurement direction is typically perpendicular to the display surface with the screen rotated to its center to develop the desired measurement viewing angle.

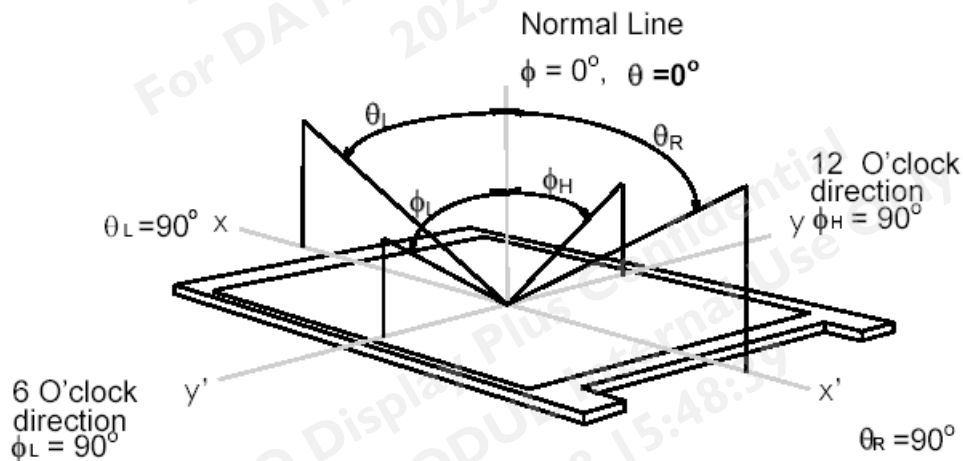

3. Functional Block Diagram

The following diagram shows the functional block of the 5.7 inch color TFT/LCD module:

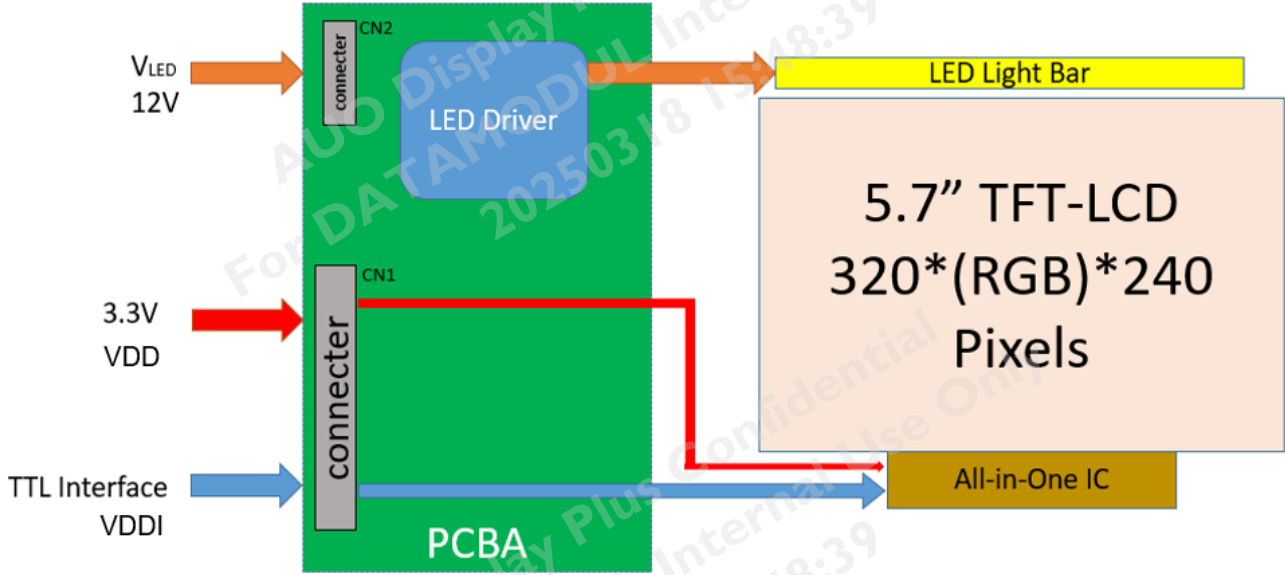

4. Absolute Maximum Ratings

4.1 Absolute Ratings of TFT LCD Module

Item	Symbol	Min	Max	Unit	Remark
Logic/LCD Drive Voltage	VDD	-0.3	+4.0	Volt	Ta= 25°C
LCD Input Signal Voltage	VIN	-0.3	+4.0	Volt	Ta= 25°C
LED BLU Drive Voltage	VLED	-0.3	+26.5	Volt	Ta= 25°C
LED Dimming Input Voltage	V _{PWM}	-0.3	+26.5	Volt	Ta= 25°C
LED On/Off Input Voltage	V _{LED On/Off}	-0.3	+26.5	Volt	Ta= 25°C

4.2 Absolute Ratings of Environment

Item	Symbol	Min	Max	Unit	Remark
Operating Temperature	TOP	-30	+85	°C	Note 1, 2
Operation Humidity	HOP	5	90	%RH	Note 1, 2
Storage Temperature	TST	-30	+85	°C	Note 1
Storage Humidity	HST	5	90	%RH	Note 1

Note 1: Maximum Wet-Bulb should be 39°C and no condensation.

Note 2: Only operation is guaranteed. Optical performance should be evaluated at 25°C only.

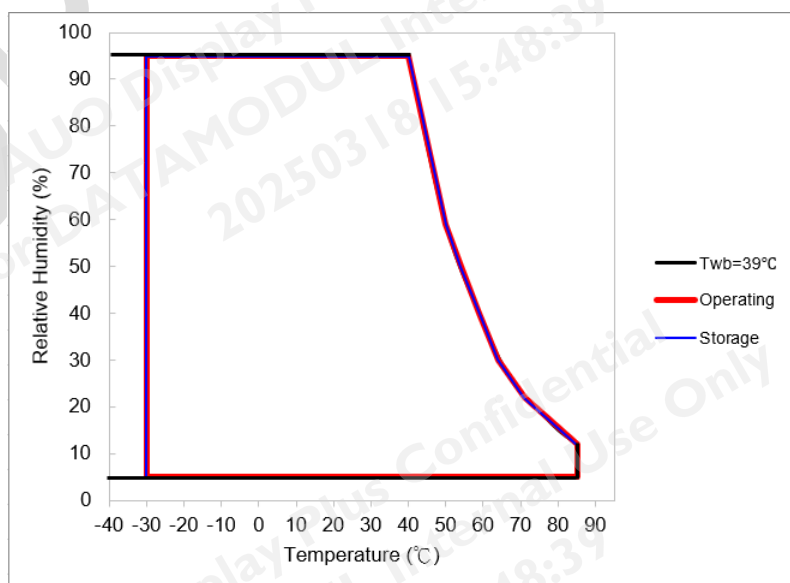

5. Electrical Characteristics

5.1 TFT LCD Module

5.1.1 Power Specification

Symbol	Parameter	Min	Typ	Max	Units	Remark
VDD	Logic/LCD Drive Voltage	3.0	3.3	3.6	[Volt]	
VDDI	LCD Input Signal Voltage	3.0	3.3	3.6	[Volt]	
IDD	VDD Current	-	27	30	[mA]	All White Pattern (VDD=3.3V, at 60Hz)
Irush	LCD Inrush Current	-	-	280	[A]	Note 1
PDD	VDD Power		0.09	0.1	[Watt]	All White Pattern (VDD=3.3V, at 60Hz)
VDDrp	Allowable Logic/LCD Drive Ripple Voltage	-	-	100	mVp-p	All White Pattern (VDD=3.3V, at 60Hz)

Note 1: Measurement condition:

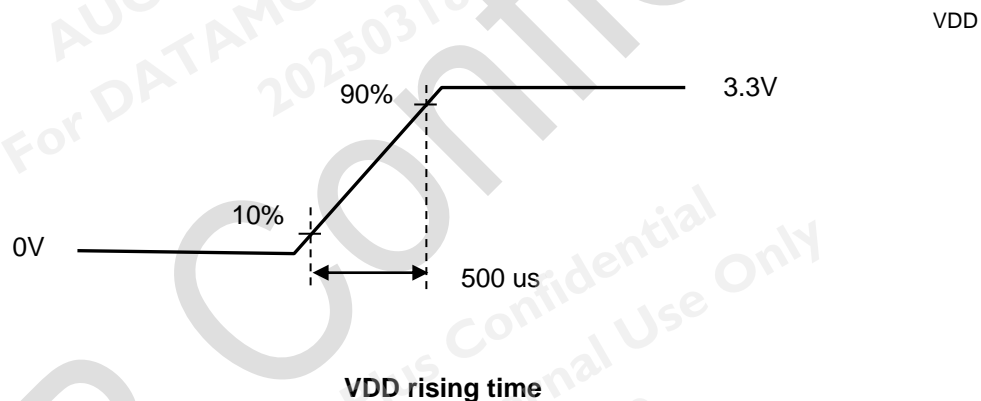

5.1.2 Signal Electrical Characteristics

Input signals shall be low or Hi-Z state when VDD is off.

Parameter	Symbol	Min.	Typ.	Max.	Unit	Remarks
Logic Input Voltage for Display Signals	High	V _{IH}	0.7V _D	-	V _D	Volt
	Low	V _{IL}	0	-	0.3V _D	Volt
Input Voltage for RL/UD	High	V _{IH}	0.7V _D	-	V _D	Volt
	Low	V _{IL}	0	-	0.2V _D	Volt

5.2 Backlight Unit

5.2.1 Parameter guideline for LED

Following characteristics are measured under stable condition using a LED driving board at 25°C(Room Temperature).

Symbol	Parameter	Min	Typ	Max	Units	Remark
V _{LED}	Input Voltage	9	12	20	Volt	
I _{LED}	Input Current	-	0.076	0.079	A	V _{LED} =12V, D _{PWM} =100%
P _{LED}	Power Consumption	-	0.91	0.95	W	V _{LED} =12V, D _{PWM} =100%
I _{rushLED}	Inrush Current	-		1.5	A	V _{LED} =12V, D _{PWM} =100%
V _{PWM DIM}	Dimming control Voltage High	2.0	3.3	5	Volt	Note 1,2
	Dimming control Voltage Low	-	-	0.15	Volt	
F _{PWM}	Dimming Frequency	200		25K	Hz	
D _{PWM}	Dimming duty cycle	1		100	%	
V _{LED On/Off}	On Control Voltage	2	3.3	5	Volt	Note 3, 4
	Off Control Voltage	-	-	0.6	Volt	
I _F	LED Forward Current		33		mA	Ta = 25oC
V _F	LED Forward Voltage	22.4	23.6	24.8	Volt	I _F = 33mA, Ta = 25°C
Operating Life		70,000	-	-	Hrs	Note 5, 6, 7

Note 1: PWM dimming function can be operated by PWM signal. PWM duty cycle can adjust white Luminance.

(PWM High: ON and PWM Low: OFF)

Note 2: PWM signal can not be floating and pull-down to ground when waiting.

Note 3: V_{ENABLE} must be turned on late than V_{LED} and PWM Signal.

Note 4: V_{ENABLE} must be turned off early than V_{LED} and PWM Signal.

Note 5: If G057QAN01.0 module is driven at high ambient temperature & humidity condition. The operating life will be reduced.

Note 6: Operating life means brightness goes down to 50% initial brightness. Min. operating life time is estimated data.

Note 7: The test condition is 33mA in 25°C room temperature.

6. Signal Characteristic

6.1 Pixel Format Image

Following figure shows the relationship between input signal and LCD pixel format.

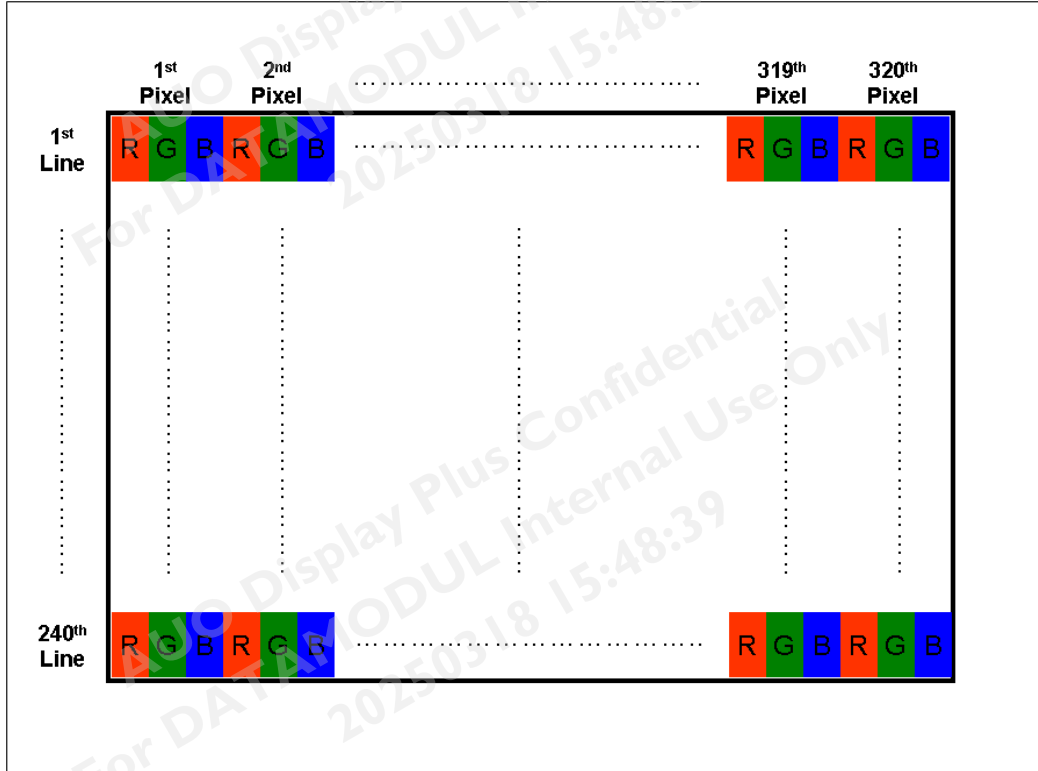

6.2 Scanning Direction

The following figures show the image seen from the front view. The arrow indicates the direction of scan.

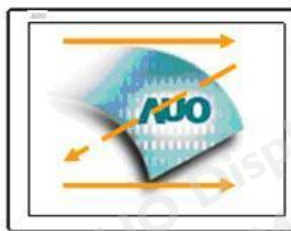

R/L=Low or NC; U/D=High or NC



R/L=High; U/D=High or NC



R/L=Low or NC; U/D=Low



R/L=High; U/D=Low

6.3 TFT- LCD Interface Signal Description

Pin#	Signal Name	Description
1	GND	Ground
2	DOTCLK	Dot clock
3	NC	NC
4	NC	NC
5	GND	Ground
6	R0	Red data(LSB)
7	R1	Red data
8	R2	Red data
9	R3	Red data
10	R4	Red data
11	R5	Red data(MSB)
12	GND	Ground
13	G0	Green data(LSB)
14	G1	Green data
15	G2	Green data
16	G3	Green data
17	G4	Green data
18	G5	Green data(MSB)
19	GND	Ground
20	B0	Blue data(LSB)
21	B1	Blue data
22	B2	Blue data
23	B3	Blue data
24	B4	Blue data
25	B5	Blue data(MSB)
26	GND	Ground
27	DE	Data enable signal
28	VDD	Power supply (3.3V Typ. Only)
29	VDD	Power supply (3.3V Typ. Only)
30	R/L	Horizontal reverse scan
31	U/D	Vertical reverse scan
32	NC	NC
33	GND	Ground

Note 1: "Low" stands for 0V. "High" stands for 3.3V. "NC" stands for "No Connection".

6.4 The Input Data Format

This product displays 262,144 colors in terms of the 64 grey levels on RGB respectively. The following table demonstrates the display of input data.

Display colors		Data signal (0 : Low level, 1: High level)																	
		R5	R4	R3	R2	R1	R0	G5	G4	G3	G2	G1	G0	B5	B4	B3	B2	B1	B0
Basic colors	Black	0	0	0	0	0	0	0	0	0	0	0	0	0	0	0	0	0	0
	Blue	0	0	0	0	0	0	0	0	0	0	0	0	1	1	1	1	1	1
	Red	1	1	1	1	1	1	0	0	0	0	0	0	0	0	0	0	0	0
	Magenta	1	1	1	1	1	1	0	0	0	0	0	0	1	1	1	1	1	1
	Green	0	0	0	0	0	0	1	1	1	1	1	1	0	0	0	0	0	0
	Cyan	0	0	0	0	0	0	1	1	1	1	1	1	1	1	1	1	1	1
	Yellow	1	1	1	1	1	1	1	1	1	1	1	1	0	0	0	0	0	0
	White	1	1	1	1	1	1	1	1	1	1	1	1	1	1	1	1	1	1
Red grayscale	Black	0	0	0	0	0	0	0	0	0	0	0	0	0	0	0	0	0	0
	Dark	0	0	0	0	0	1	0	0	0	0	0	0	0	0	0	0	0	0
	↑																		
	↓																		
	bright	1	1	1	1	0	1	0	0	0	0	0	0	0	0	0	0	0	0
	Red	1	1	1	1	1	1	0	0	0	0	0	0	0	0	0	0	0	0
Green grayscale	Black	0	0	0	0	0	0	0	0	0	0	0	0	0	0	0	0	0	0
	Dark	0	0	0	0	0	0	0	0	0	1	0	0	0	0	0	0	0	0
	↑																		
	↓																		
	bright	0	0	0	0	0	0	1	1	1	1	0	1	0	0	0	0	0	0
	Green	0	0	0	0	0	0	1	1	1	1	1	1	0	0	0	0	0	0
Blue grayscale	Black	0	0	0	0	0	0	0	0	0	0	0	0	0	0	0	0	0	0
	Dark	0	0	0	0	0	0	0	0	0	0	0	0	0	0	0	0	1	0
	↑																		
	↓																		
	bright	0	0	0	0	0	0	0	0	0	0	0	0	1	1	1	1	0	1
	Blue	0	0	0	0	0	0	0	0	0	0	0	0	1	1	1	1	1	1

6.5 Interface Timing

6.5.1 Timing Characteristics

Parameter		Symbol	Min.	Typ.	Max.	Unit
Clock frequency		$1/T_{Clock}$	5	6	8	MHz
Data	Setup Time	T_{dsu}	12			ns
	Hold Time	T_{dhd}	12			ns
DE	Setup Time	T_{dest}	12			ns
	Hold Time	T_{dehd}	12			ns
HSYNC	Period Time	T_h	325	371	438	DCLK
	Display Period	T_{hdisp}		320		
	Back Porch	T_{hbp}	3	43	43	
	Front Porch	T_{hfp}	2	8	75	
	Pulse Width	T_{hw}	2	4	43	
VSYNC	Period Time	T_v	244	260	289	HSYNC
	Display Period	T_{vdisp}		240		
	Back Porch	T_{vbp}	2	12	12	
	Front Porch	T_{vfp}	2	8	37	
	Pulse Width	T_{vw}	2	4	12	
Frame Rate		F		60	70	Hz

Note: DE mode only.

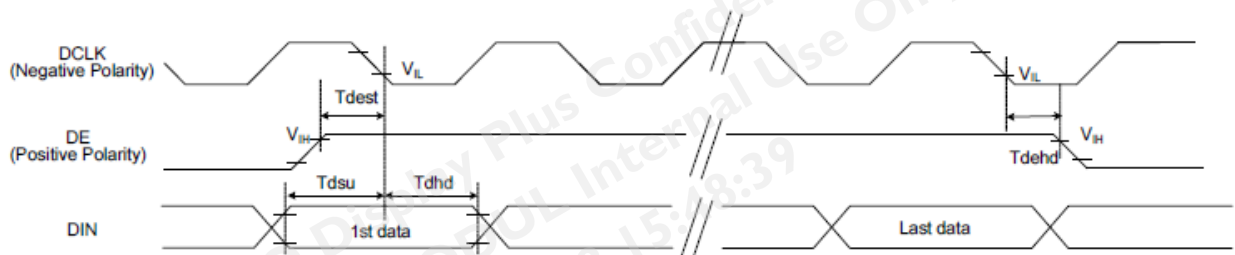

6.5.2 Input Timing Diagram

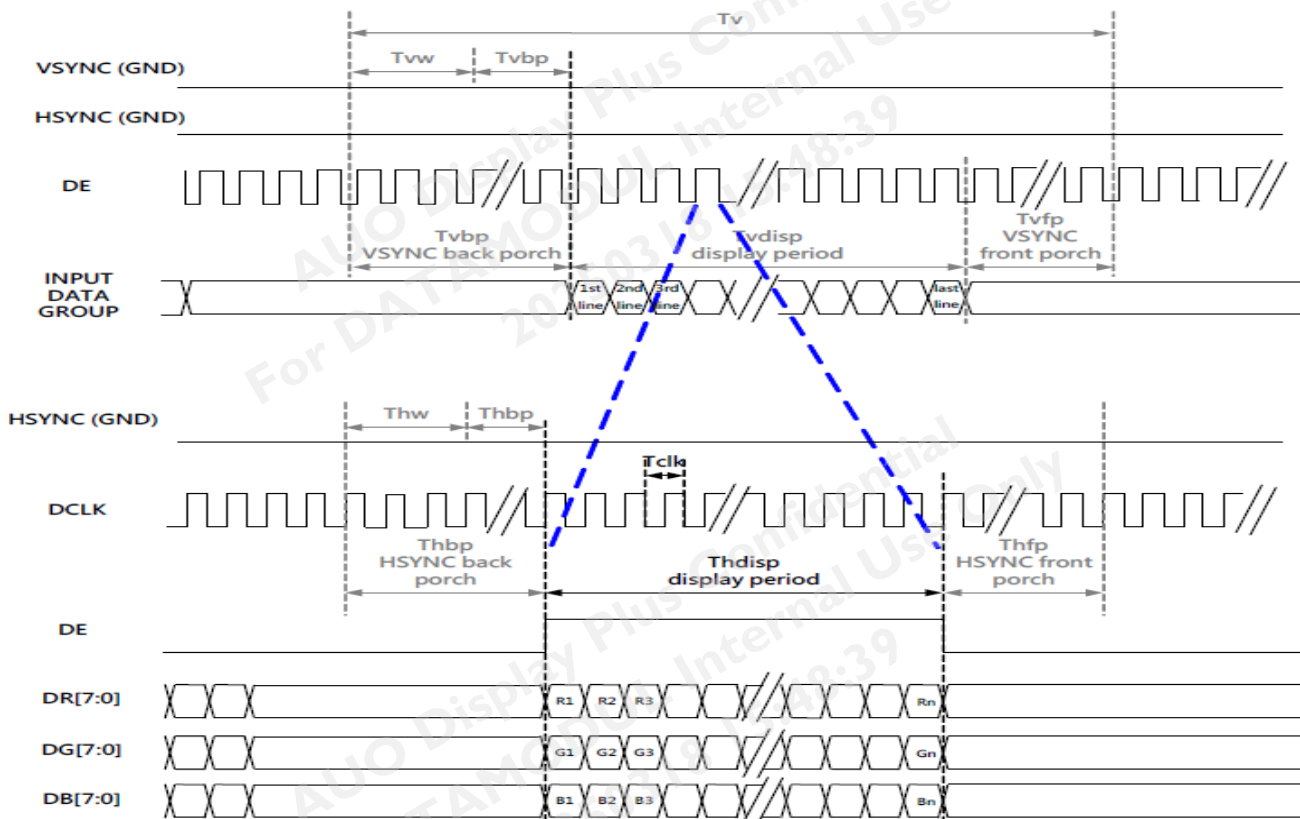

6.6 LED Backlight Unit Interface Signal Description

Pin #	Symbol	Pin Description
1	V _{LED}	12V input
2	V _{LED}	12V input
3	GND	Ground
4	GND	Ground
5	PWM DIM	1~100% PWM dimming
6	LED On/Off	0V-Off; 2~5V-On

Note 1: "NC" stands for "No Connection"

6.7 Power ON/OFF Sequence

VDD power and LED on/off sequence is as below. Interface signals are also shown in the chart. Signals from any system shall be Hi-Z state or low level when VDD is off.

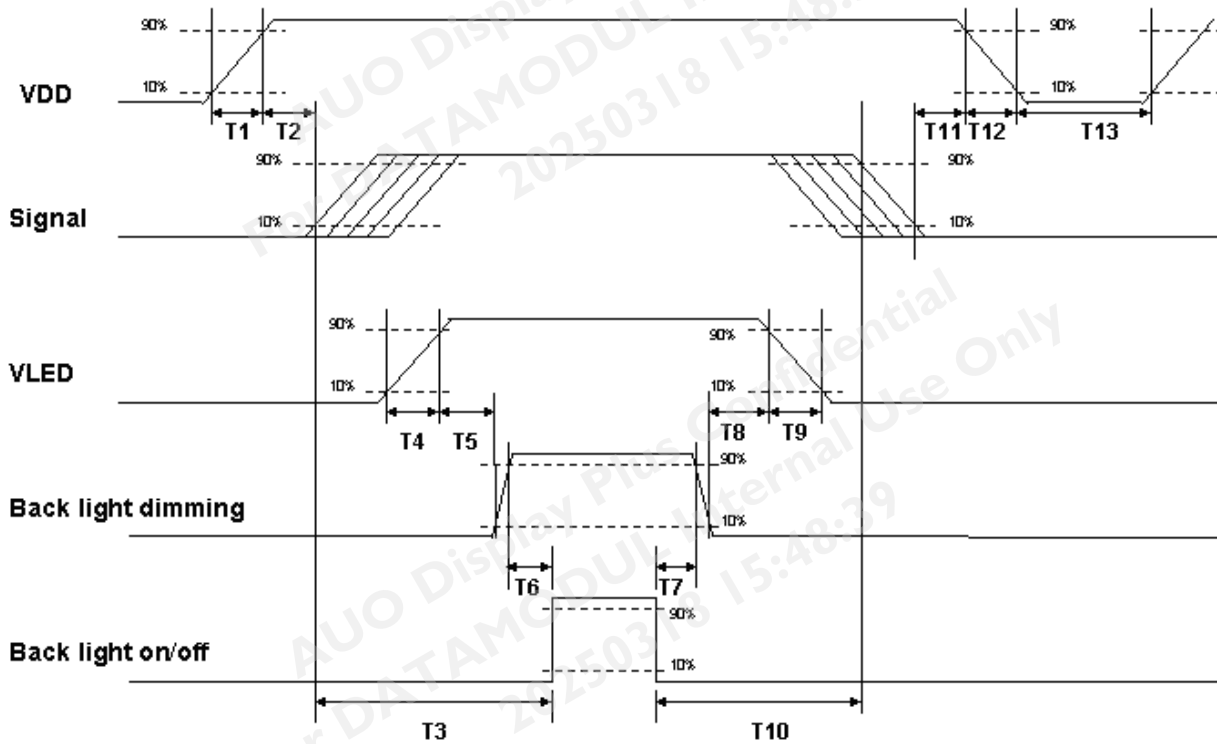

Power ON/OFF sequence timing

Parameter	Value			Units
	Min.	Typ.	Max.	
T1	0.5	-	10	[ms]
T2	30	40	50	[ms]
T3	250	-	-	[ms]
T4	0.5	-	10	[ms]
T5	10	-	-	[ms]
T6	10	-	-	[ms]
T7	0	-	-	[ms]
T8	10	-	-	[ms]
T9	-	-	10	[ms]
T10	110	-	-	[ms]
T11	60	80	100	[ms]
T12	-	-	10	[ms]
T13	1000	-	-	[ms]

The above on/off sequence should be applied to avoid abnormal function in the display. Please make sure to turn off the power when you plug the cable into the input connector or pull the cable out of the connector.

7. Connector & Pin Assignment

Physical interface is described as for the connector on module. These connectors are capable of accommodating the following signals and will be following components.

7.1 TFT- LCD Signal (CN1): LCD Connector

Manufacturer	Starconn
Connector Model Number	089H33-000100-G2-R

7.2 LED Backlight Unit (CN2): Backlight Connector

Manufacturer	CivLux
Connector Model Number (female)	CI1106M1HR0-NH
Mating Connector Model Number (male)	Housing: CI1106S0000-NH, Contact: CI11T011PP0 or compatible

7.3 LED Light Bar Input (CN3): Light Bar Connector

Manufacturer	JST
Connector Model Number (female)	SM06B-SHLK-G-TF(HF)
Mating Connector Model Number (male)	Housing: SHLP-06V-BK-B(HF), Contact: SSSL-003T-P0.2 or compatible

Pin #	Symbol	Pin Description	Cable color
1	NC	-	No cable
2	NC	-	No cable
3	AN1	Channel 1 LED anode	Red
4	CA1	Channel 1 LED cathode	White
5	NC	-	No cable
6	NC	-	No cable

7.4 Connector Illustration

7.4.1 PIN 1 definition of CN1 and CN2

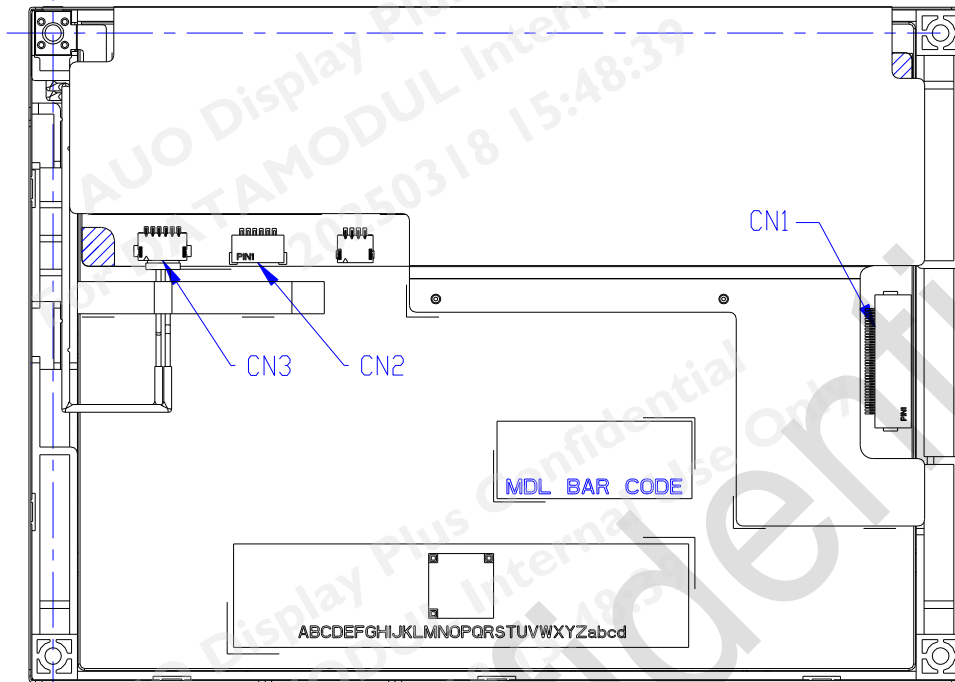

(Rear side of TFT-LCD)

7.4.2 PIN 1 definition of CN3

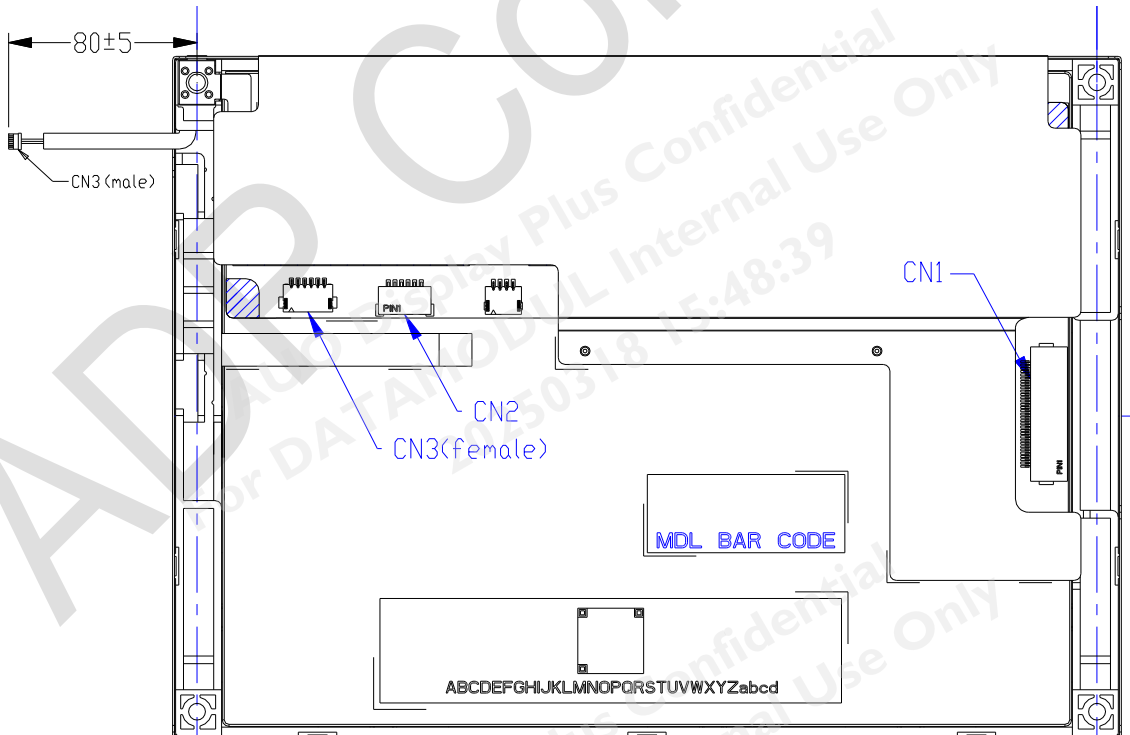

(Rear side of TFT-LCD)

8. Reliability Test Criteria

Items	Required Condition	Note
Temperature Humidity Bias	40°C/90%,300 hours	Note 2
High Temperature Operation	85°C ,300 hours	Note 2
Low Temperature Operation	-30°C ,300 hours	Note 2
Hot Storage	85°C ,300 hours	Note 2
Cold Storage	-30°C ,300 hours	Note 2
Thermal Shock Test	-20°C/30 min ,60°C/30 min ,100cycles	Note 2
Hot Start Test	85°C/1 Hr (min.), power on/off per 5 minutes, repeat 5 times	Note 2
Cold Start Test	-30°C/1 Hr (min.), power on/off per 5 minutes, repeat 5 times	Note 2
Shock Test (Non-Operating)	50G,20ms,Half-sine wave,(±X, ±Y, ±Z)	Note 2
Vibration Test (Non-Operating)	1.5G, (10~200Hz, P-P) 30 mins/axis (X, Y, Z)	Note 2
On/off test	On/10 sec, Off/10 sec, 30,000 cycles	Note 1,2
ESD	Contact Discharge:±8KV,150pF(330Ω)1sec,8 points,25 times/ point Air Discharge: ±15KV, 150pF(330Ω)1sec, 8 points, 25 times/ point	Note 2
Altitude Test	Operating: 14,000 ft, Ramp: 2000 ft/min, 8hrs Non-operating: 40,000 ft, Ramp: 2000 ft/min, 24hrs	Note 2

Note 1: According to EN61000-4-2, ESD class B: Some performance degradation allowed. No data lost
. Self-recoverable. No hardware failures.

Note 2:

- Water condensation is not allowed for each test items.
- Each test is done by new TFT-LCD module Don't use the same TFT-LCD module repeatedly for reliability test.
- The reliability test is performed only to examine the TFT-LCD module capability.
- To inspect TFT-LCD module after reliability test, please store it at room temperature and room humidity for 24 hours at least in advance.
- No function failure occurs.

9. Mechanical Characteristics

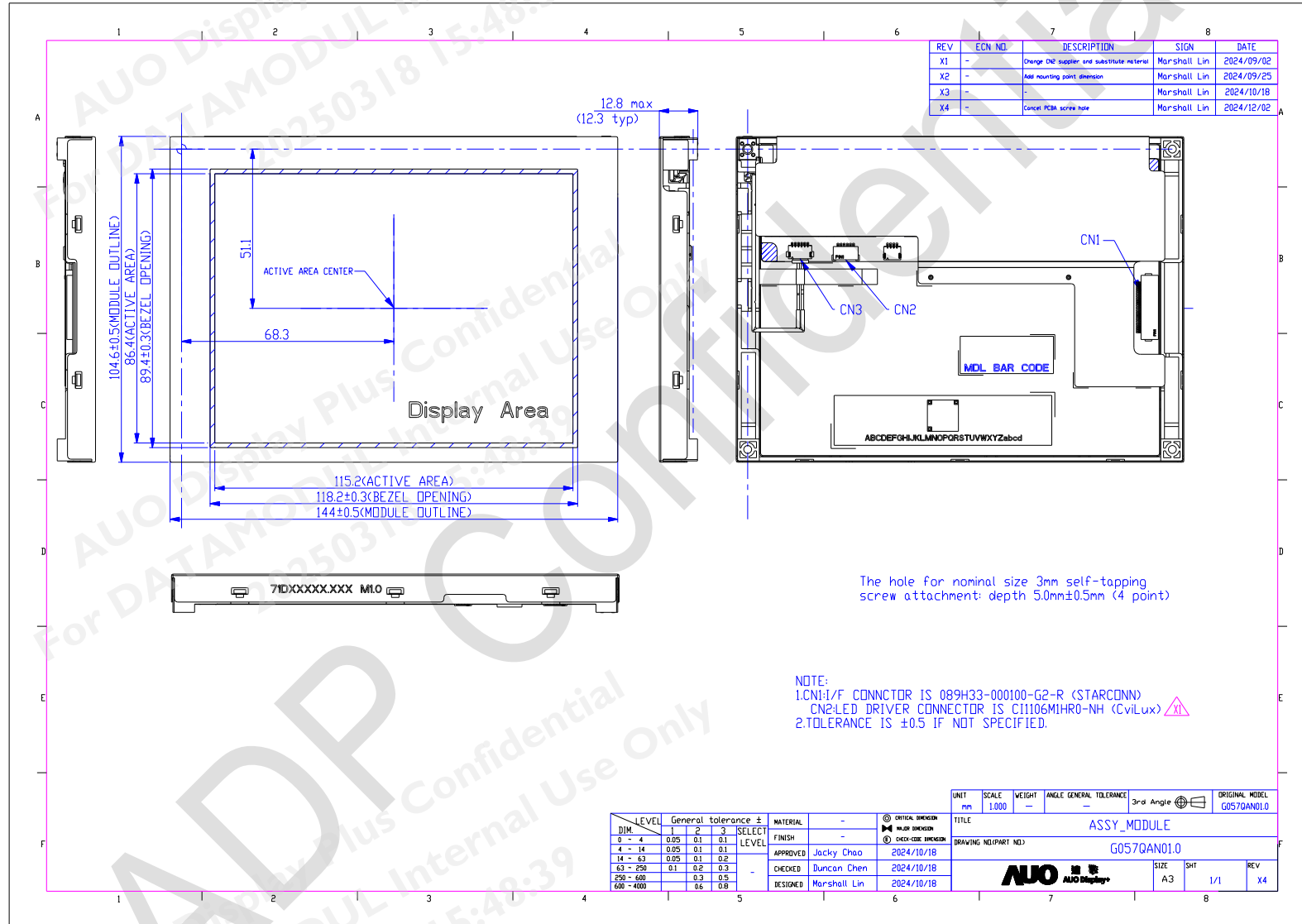

10. Label and Packaging

10.1 Shipping Label (on the rear side of TFT-LCD display)



10.2 Carton Package

Max. capacity: 60 pieces TFT-LCD module per carton

Max. weight: 12.95 kg per carton

Outside dimension of carton: 520(L)mm* 340(W)mm* 250(H)mm

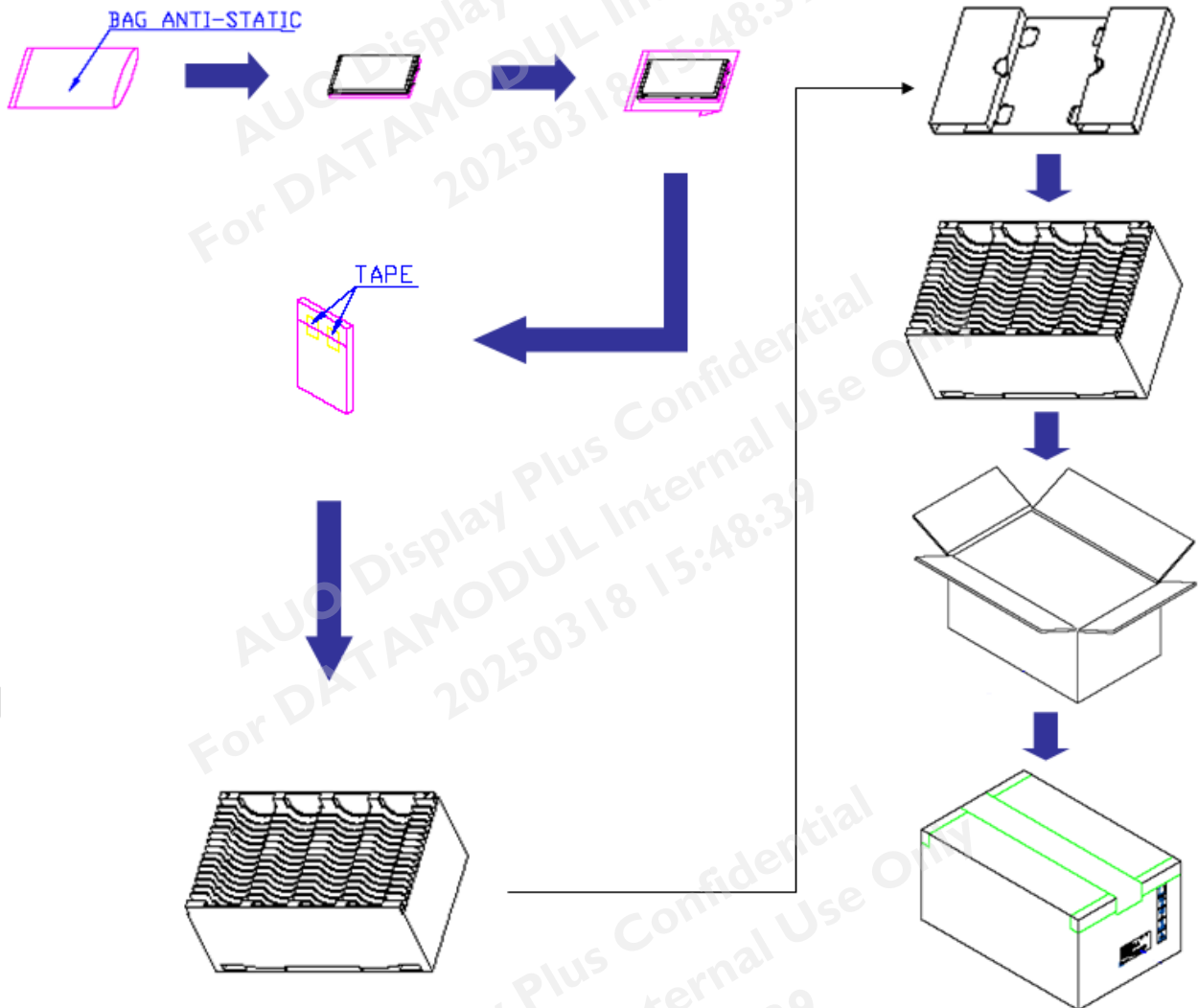

11 Safety

11.1 Sharp Edge Requirements

There will be no sharp edges or corners on the display assembly that could cause injury.

11.2 Materials

11.2.1 Toxicity

There will be no carcinogenic materials used anywhere in the display module. If toxic materials are used, they will be reviewed and approved by the responsible ADP toxicologist.

11.2.2 Flammability

All components including electrical components that do not meet the flammability grade UL94-V1 in the module will complete the flammability rating exception approval process.

The printed circuit board will be made from material rated 94-V1 or better. The actual UL flammability rating will be printed on the printed circuit board.

11.3 Capacitors

If any polarized capacitors are used in the display assembly, provisions will be made to keep them from being inserted backwards.

11.4 National Test Lab Requirement

The display module will satisfy all requirements for compliance to: IEC/UL 62368-1

DATA MODUL

Passion Displayed

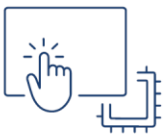

All good things come in threes:

With **Hardware**, **Software** and **Services**, we realise unique display solutions that turn your ideas into reality.

www.data-modul.com

