



SPECIFICATION



G084SN03 V3

8.4" - SVGA - LVDS

Version: 2.0

Date: 09.05.2014

Note: This specification is subject to change without prior notice



- Preliminary Specifications
- Final Specifications

Module	8.4 Inch Color TFT-LCD
Model Name	G084SN03 V3

<table border="1"><thead><tr><th style="width: 50%;">Customer</th><th style="width: 50%;">Date</th></tr></thead><tbody><tr><td>_____</td><td>_____</td></tr><tr><td> Checked & Approved by</td><td></td></tr><tr><td>_____</td><td>_____</td></tr></tbody></table>	Customer	Date	_____	_____	 Checked & Approved by		_____	_____	<table border="1"><thead><tr><th style="width: 50%;">Approved by</th><th style="width: 50%;">Date</th></tr></thead><tbody><tr><td>Grace Hung</td><td>2014/05/09</td></tr><tr><td> Prepared by</td><td></td></tr><tr><td>Johnson Lin</td><td>2014/05/09</td></tr></tbody></table>	Approved by	Date	Grace Hung	2014/05/09	 Prepared by		Johnson Lin	2014/05/09
Customer	Date																
_____	_____																
 Checked & Approved by																	
_____	_____																
Approved by	Date																
Grace Hung	2014/05/09																
 Prepared by																	
Johnson Lin	2014/05/09																
Note: This Specification is subject to change without notice.	General Display Business Division / AU Optronics corporation																

Contents

1. Operating Precautions	4
2. General Description	5
2.1 Display Characteristics	5
2.2 Optical Characteristics	6
3. Functional Block Diagram	9
4. Absolute Maximum Ratings.....	10
4.1 Absolute Ratings of TFT LCD Module.....	10
4.2 Absolute Ratings of Environment.....	10
5. Electrical Characteristics.....	11
5.1 TFT LCD Module	11
5.2 Backlight Unit.....	13
6. Signal Characteristic.....	14
6.1 Pixel Format Image.....	14
6.2 Signal Description	15
6.3 Scanning Direction.....	16
6.4 The Input Data Format.....	17
6.5 Interface Timing	18
6.6 Power ON/OFF Sequence	19
7. Connector & Pin Assignment	20
7.1 TFT LCD Module: LVDS Connector.....	20
7.2 Backlight Unit(CN2): LED Driver Connector	20
7.3 LED Light Bar Input Connector (CN3):	21
8. Reliability Test Criteria.....	22
9. Mechanical Characteristics	23
9.1 LCM Front View	23
9.2 LCM Rear View	24
10. Label and Packaging.....	25
10.1 Shipping Label (on the rear side of TFT-LCD display).....	25
10.2 Carton Package	25
11 Safety.....	26
11.1 Sharp Edge Requirements.....	26
11.2 Materials.....	26
11.3 Capacitors.....	26
11.4 National Test Lab Requirement.....	26

**Record of Revision**

Version and Date	Page	Old description	New Description
0.0 2011/04/07		First Edition	
0.1 2011/08/01	5		Update Power Consumption, Weight
	6		Update Optical Characteristics
	11		Update Power Specification
	13		Parameter guideline for LED
	21	High voltage	Update LED Pin3: Low voltage Add Cable color
1.0 2011/12/28	6	White Luminance condition @ $I_F=80\text{mA}$	White Luminance condition @ $I_F=25\text{mA}$
	6	TBD	Update Optical Characteristics spec.
	13	TBD	Update Parameter guideline for LED backlight
	23, 24	LCM Front, Rear View	Update LCM Front, Rear View
2.0 2014/05/09	15	6.2 Signal Description: Pin 19 / 20	pin19:VDD and pin20:GND for 6 bit input mode

1. Operating Precautions

- 1) Since front polarizer is easily damaged, please be cautious not to scratch it.
- 2) Be sure to turn off power supply when inserting or disconnecting from input connector.
- 3) Wipe off water drop immediately. Long contact with water may cause discoloration or spots.
- 4) When the panel surface is soiled, wipe it with absorbent cotton or soft cloth.
- 5) Since the panel is made of glass, it may be broken or cracked if dropped or bumped on hard surface.
- 6) To avoid ESD (Electro Static Discharge) damage, be sure to ground yourself before handling TFT-LCD Module.
- 7) Do not open nor modify the module assembly.
- 8) Do not press the reflector sheet at the back of the module to any direction.
- 9) In case if a module has to be put back into the packing container slot after it was taken out from the container, do not press the center of the LED Reflector edge. Instead, press at the far ends of the LED Reflector edge softly. Otherwise the TFT Module may be damaged.
- 10) At the insertion or removal of the Signal Interface Connector, be sure not to rotate nor tilt the Interface Connector of the TFT Module.
- 11) After installation of the TFT Module into an enclosure (Notebook PC Bezel, for example), do not twist nor bend the TFT Module even momentarily. At designing the enclosure, it should be taken into consideration that no bending/twisting forces are applied to the TFT Module from outside. Otherwise the TFT Module may be damaged.
- 12) Small amount of materials having no flammability grade is used in the LCD module. The LCD module should be supplied by power complied with requirements of Limited Power Source (IEC60950 or UL1950), or be applied exemption.
- 13) Severe temperature condition may result in different luminance, response time.
- 14) Continuous operating TFT-LCD Module under high temperature environment may accelerate LED light bar exhaustion and reduce luminance dramatically.
- 15) The data on this specification sheet is applicable when LCD module is placed in landscape position.
- 16) Continuous displaying fixed pattern may induce image sticking. It is recommended to use screen saver or shuffle content periodically if fixed pattern is displayed on the screen.

2. General Description

This specification applies to the 8.4 inch color TFT LCD module G084SN03 V3.

This module is designed for display units for Industrial Applications.

The screen format is intended to support the SVGA (800(H) x 600(V)) screen and 16.2M (RGB 8-bits) or 262k colors (RGB 6-bits).

All input signals are LVDS interface compatible.

LED Driver is embedded.

This is a RoHS product.

2.1 Display Characteristics

The following items are characteristics summary on the table under 25 °C condition:

Items	Unit	Specifications
Screen Diagonal	[inch]	8.4 (213.4mm)
Active Area	[mm]	170.4(H) x 127.8(V)
Pixels H x V		800x3(RGB) x 600
Pixel Pitch	[mm]	0.213x 0.213
Pixel Arrangement		R.G.B. Vertical Stripe
Display Mode		TN, Normally White
Nominal Input Voltage VDD	[Volt]	3.3 (typ)
Typical Power Consumption	[Watt]	3.66 (typ)
Weight	[Grams]	190 (typ)
Physical Size	[mm]	203.0(W) x 142.5(H) x 5.7(D) (typ.)
Electrical Interface		1 channel LVDS
Surface Treatment		Anti-glare, Hardness 3H
Support Color		262K(6-bit) / 16.2M(8-bit)
Temperature Range Operating Storage (Non-Operating)	[°C] [°C]	-20 to 70 (panel surface temperature) -20 to 70
RoHS Compliance		RoHS Compliance

2.2 Optical Characteristics

The optical characteristics are measured under stable conditions at 25°C (Room Temperature):

Item	Unit	Conditions	Min.	Typ.	Max.	Note
White Luminance	[cd/m ²]	I _F = 25mA (center point)	200	250	-	1
Uniformity	%	9 Points	70	75	-	1, 2, 3
Contrast Ratio			400	600	-	4
Response Time	[msec]	Rising	-	20	30	5
	[msec]	Falling	-	10	20	
	[msec]	Raising + Falling	-	30	50	
Viewing Angle	[degree]	Horizontal (Right) CR ≥ 10 (Left)	70	80	-	6
	[degree]		70	80	-	
	[degree]	Vertical (Upper) CR ≥ 10 (Lower)	65 50	80 60	- -	
Color / Chromaticity Coordinates (CIE 1931)		Red x	0.551	0.601	0.651	
		Red y	0.288	0.338	0.388	
		Green x	0.321	0.371	0.421	
		Green y	0.504	0.554	0.604	
		Blue x	0.100	0.150	0.200	
		Blue y	0.048	0.098	0.148	
		White x	0.26	0.31	0.36	
		White y	0.28	0.33	0.38	
Color Gamut	%			45	-	

Note 1: Measurement method

Equipment : Pattern Generator, Power Supply, Digital Voltmeter, Luminance meter (SR_3 or equivalent)

Aperture 1° with 50cm viewing distance

Test Point Center

Environment < 1 lux

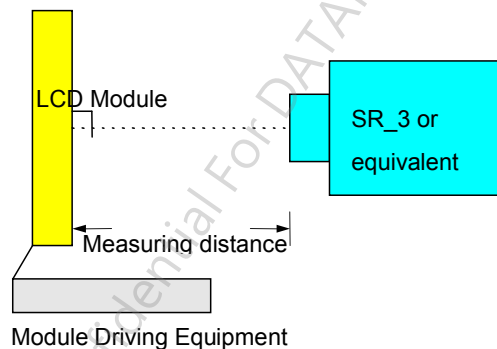

Note 2: Definition of 9 points position (Display active area : 170.4(H) x 127.8(V))

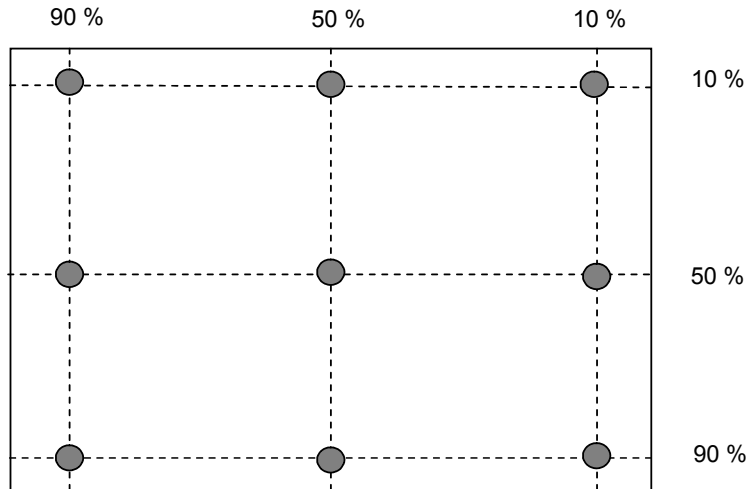

Note 3: The luminance uniformity of 9 points is defined by dividing the minimum luminance value by the maximum test point luminance.

$$\delta_{w9} = \frac{\text{Minimum Brightness of nine points}}{\text{Maximum Brightness of nine points}}$$

Note 4 : Definition of contrast ratio (CR):

$$\text{Contrast ratio (CR)} = \frac{\text{Brightness on the "White" state}}{\text{Brightness on the "Black" state}}$$

Note 5: Definition of response time:

The output signals of photo detector are measured when the input signals are changed from "White" to "Black" (falling time) and from "Black" to "White" (rising time), respectively. The response time interval is between 10% and 90% of amplitudes. Please refer to the figure as below.

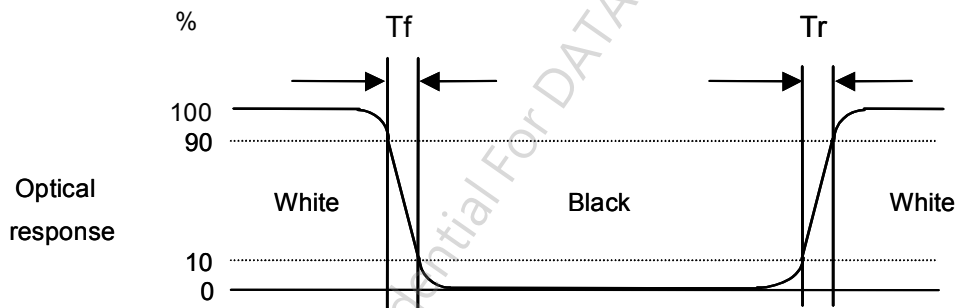

Note 6: Definition of viewing angle

Viewing angle is the measurement of contrast ratio ≥ 10 , at the screen center, over a 180° horizontal and 180°

vertical range (off-normal viewing angles). The 180° viewing angle range is broken down as below: 90° (θ) horizontal left and right, and 90° (Φ) vertical high (up) and low (down). The measurement direction is typically perpendicular to the display surface with the screen rotated to its center to develop the desired measurement viewing angle.

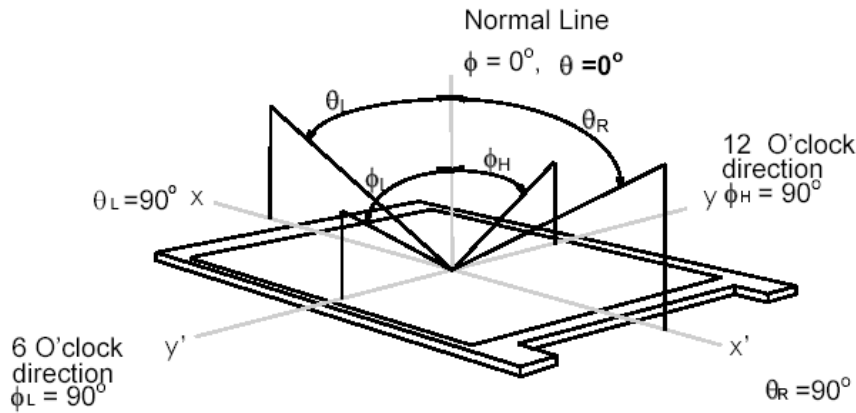

AUO Confidential For DATAMODUL Internal Use Only On 2014/07/09

3. Functional Block Diagram

The following diagram shows the functional block of the 8.4 inch color TFT/LCD module:

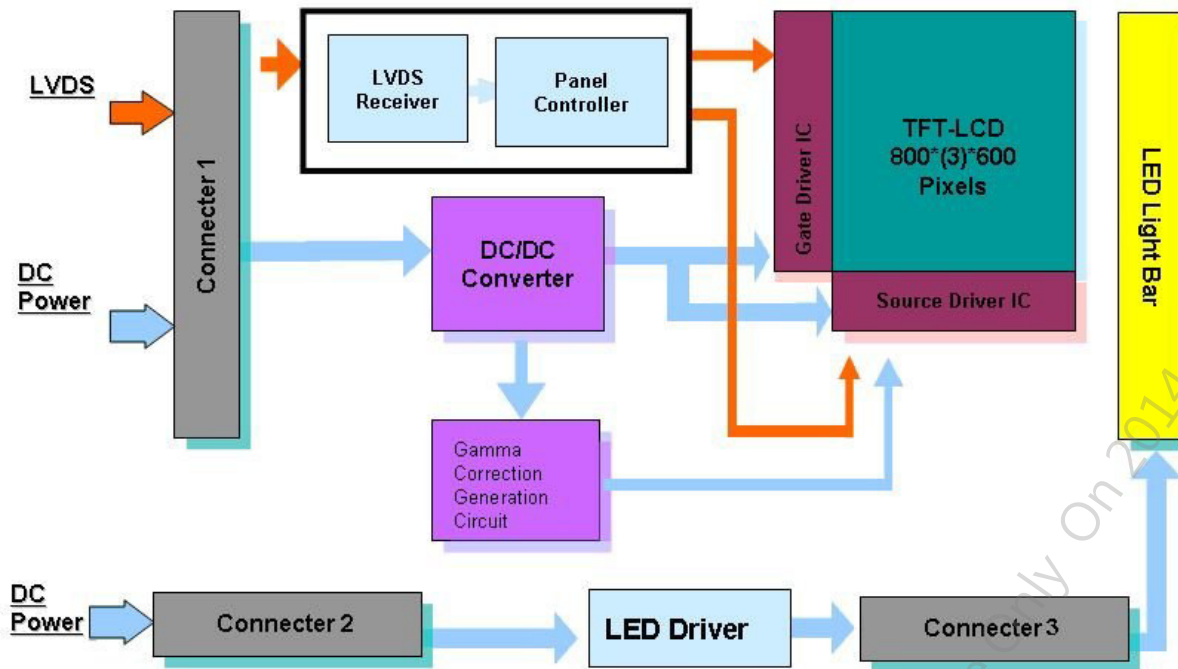

AUO Confidential For DATAMODUL Internal Use Only On 2014/07/09

4. Absolute Maximum Ratings

4.1 Absolute Ratings of TFT LCD Module

Item	Symbol	Min	Max	Unit	Conditions
Logic/LCD Drive Voltage	VDD	-0.3	+3.6	[Volt]	

4.2 Absolute Ratings of Environment

Item	Symbol	Min	Max	Unit
Operating Temperature	TOP	-20	70	[°C]
Operation Humidity	HOP	5	90	[%RH]
Storage Temperature	TST	-20	70	[°C]
Storage Humidity	HST	5	90	[%RH]

Note: Maximum Wet-Bulb should be 39°C and no condensation.

AUO Confidential For DATAMODUL Internal Use Only On 2014/07/09

5. Electrical Characteristics

5.1 TFT LCD Module

5.1.1 Power Specification

Symbol	Parameter	Min	Typ	Max	Units	Remark
VDD	Logic/LCD Drive Voltage	3.0	3.3	3.6	[Volt]	± 10%
IDD	VDD Current	-	270	330	[mA]	64 Gray Bar Pattern (VDD=3.3V, at 60Hz)
PDD	VDD Power	-	0.9	1.2	[Watt]	64 Gray Bar Pattern (VDD=3.3V, at 60Hz)

Note 1: Measurement condition:

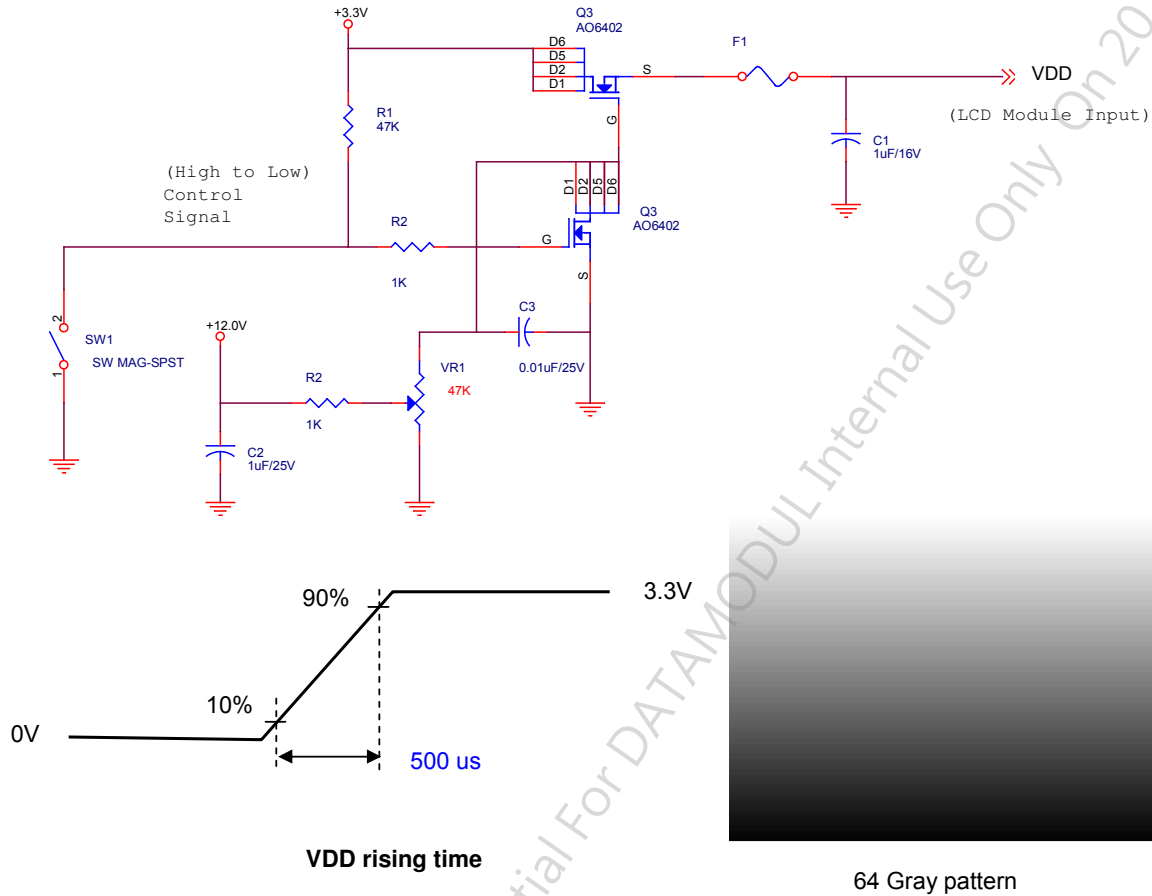

5.1.2 Signal Electrical Characteristics

Input signals shall be low or Hi-Z state when VDD is off.

Symbol	Item	Min.	Typ.	Max.	Unit	Remark
VTH	Differential Input High Threshold	-	-	100	[mV]	VICM=1.2V
VTL	Differential Input Low Threshold	-100	-	-	[mV]	VICM=1.2V
VID	Input Differential Voltage	100	400	600	[mV]	
VICM	Differential Input Common Mode Voltage	1.1		1.6	[V]	VTH/VTL=±100mV

Note: LVDS Signal Waveform.

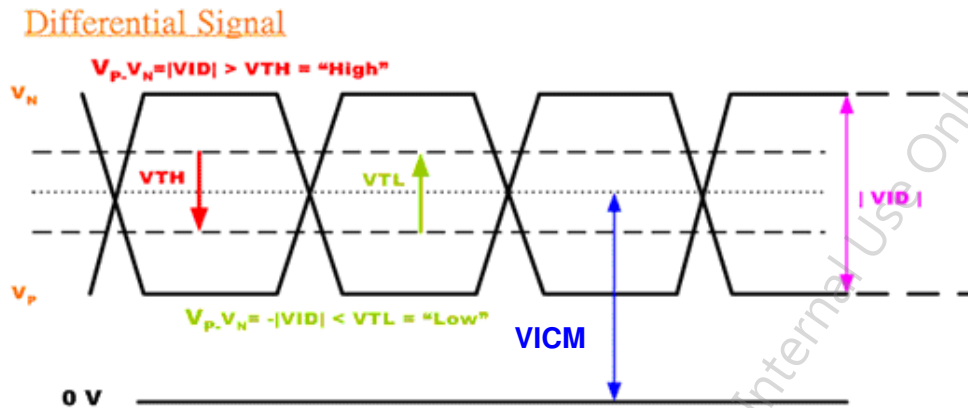

5.2 Backlight Unit

5.2.1 Parameter guideline for LED

Following characteristics are measured under a stable condition using an inverter at 25°C (Room Temperature):

Symbol	Parameter	Min.	Typ.	Max.	Unit	Remark
VCC	Input Voltage	10.8	12	13.2	[Volt]	
I _{VCC}	Input Current	-	0.23	-	[A]	100% PWM Duty
P _{VCC}	Power Consumption	-	2.76	2.97	[Watt]	100% PWM Duty
F _{PWM}	Dimming Frequency	200	-	20K	[Hz]	
	Swing Voltage	3	3.3	5	V	
	Dimming Duty Cycle	5		100	%	
I _F	LED Forward Current		25	26.3	mA	Ta = 25°C
V _F	LED Forward Voltage		28.8	32.85	Volt	I _F = 25mA, Ta = 25°C
P _{LED}	LED Power Consumption		2.16	2.628	Watt	I _F = 25mA, Ta = 25°C (total power)
Operation Lifetime		25,000	30,000		Hrs	I _F = 25mA, Ta = 25°C

Note 1: Ta means ambient temperature of TFT-LCD module.

Note 2: VCC, I_{VCC}, P_{VCC}, are defined for LED B/L.(100% duty of PWM dimming)

Note 3: I_F, V_F are defined for each channel of LED Light Bar. There are three LED channels (AN1-CA1-CA2-CA3) in back light unit.

Note 4: If G084SN03 V3 module is driven by high current or at high ambient temperature & humidity condition. The operating life will be reduced.

Note 5: Operating life means brightness goes down to 50% initial brightness. Minimum operating life time is estimated data.

6. Signal Characteristic

6.1 Pixel Format Image

Following figure shows the relationship between input signal and LCD pixel format.

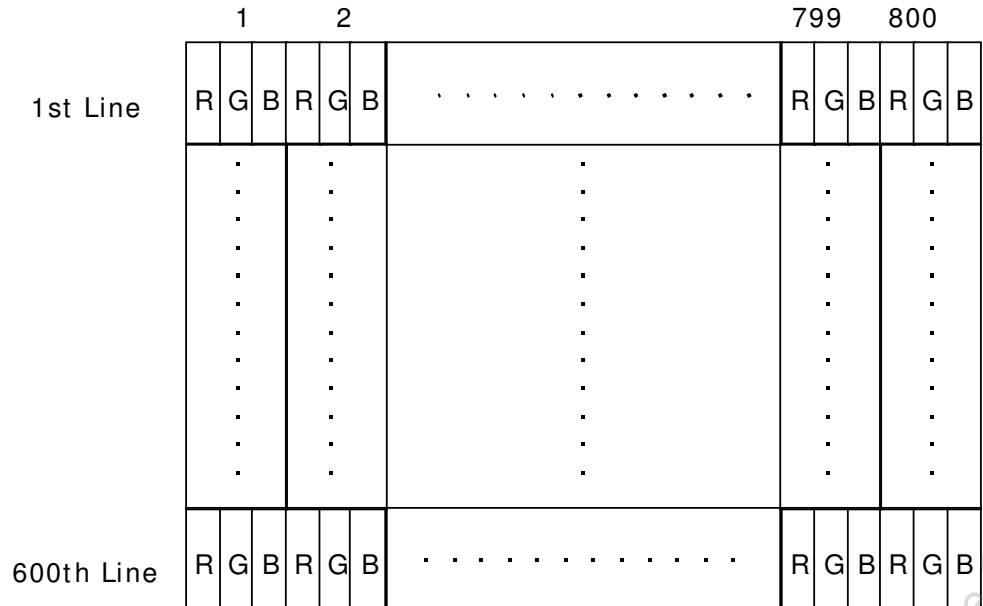

AUO Confidential For DATAMODUL Internal Use Only On 2014/07/09

6.2 Signal Description

LVDS is a differential signal technology for LCD interface and high speed data transfer device. The connector pin definition is as below.

Pin No.	Symbol	Description
1	VDD	Power Supply, 3.3V (typical)
2	VDD	Power Supply, 3.3V (typical)
3	UD	Vertical Reverse Scan Control, Low or NC → Normal Mode. High → Vertical Reverse Scan. ^{Note1}
4	LR	Horizontal Reverse Scan Control, Low or NC → Normal Mode. High → Horizontal Reverse Scan. ^{Note1}
5	RxIN1-	LVDS differential data input Pair 0
6	RxIN1+	
7	GND	Ground
8	RxIN2-	LVDS differential data input Pair 1
9	RxIN2+	
10	GND	Ground
11	RxIN3-	LVDS differential data input Pair 2
12	RxIN3+	
13	GND	Ground
14	RxCLKIN-	LVDS differential Clock input Pair
15	RxCLKIN+	
16	GND	Ground
17	SEL 68	LVDS 6/8 bit select function control, Low or NC → 6 Bit Input Mode. High → 8 Bit Input Mode. ^{Note1}
18	NC	NC
19	RxIN4-	LVDS differential data input Pair 3. Pin19:VDD & Pin20:GND for 6 Bit Input Mode ^{Note2}
20	RxIN4+	

Note1 : “Low” stands for 0V. “High” stands for 3.3V. “NC” stands for “No Connected.”

Note2 :

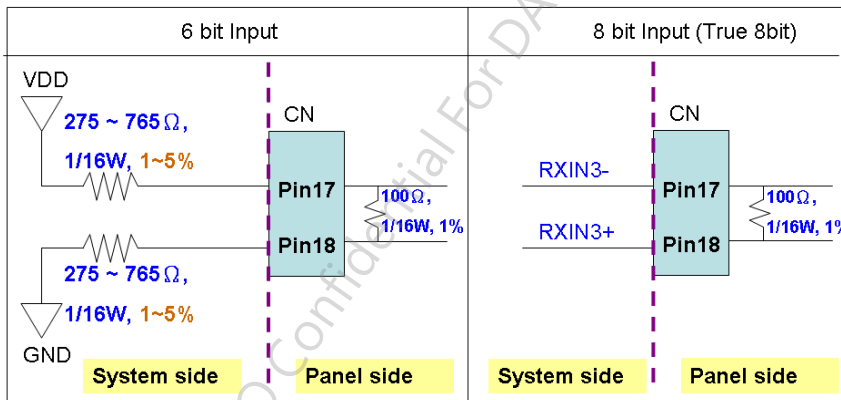

6.3 Scanning Direction

The following figures show the image seen from the front view. The arrow indicates the direction of scan.

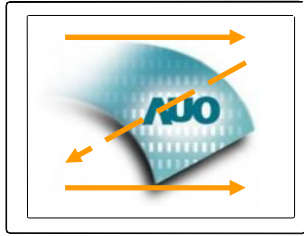

Fig. 1

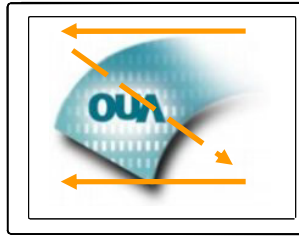

Fig. 2



Fig. 3

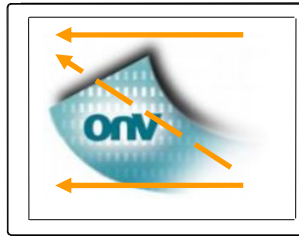

Fig. 4

Fig. 1 Normal scan (Pin3, UD = Low or NC ; Pin4, RL = Low or NC)

Fig. 2 Reverse scan (Pin3, UD = Low or NC ; Pin4, RL = High)

Fig. 3 Reverse scan (Pin3, UD = High ; Pin4, RL = Low or NC)

Fig. 4 Reverse scan (Pin3, UD = High ; Pin4, RL = High)

AUO Confidential For DATAMODUL Internal Use Only On 2014/07/09

6.4 The Input Data Format

6.4.1 SEL68

SEL68 = "Low" or "NC" for 6 bits LVDS Input

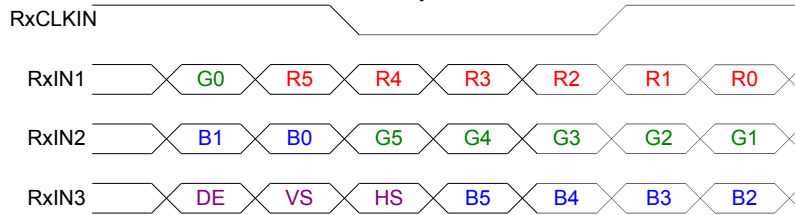

SEL68 = "High" for 8 bits LVDS Input

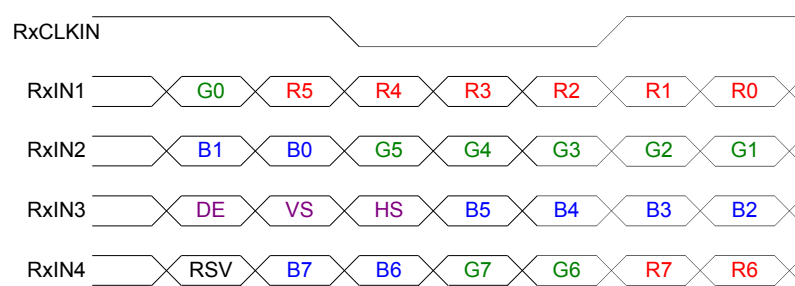

Note1: Please follow PSWG.

Note2: R/G/B data 7:MSB, R/G/B data 0:LSB

Signal Name	Description	Remark
R7	Red Data 7 (MSB)	Red-pixel Data Each red pixel's brightness data consists of these 8 bits pixel data.
R6	Red Data 6	
R5	Red Data 5	
R4	Red Data 4	
R3	Red Data 3	
R2	Red Data 2	
R1	Red Data 1	
R0	Red Data 0 (LSB)	
G7	Green Data 7 (MSB)	Green-pixel Data Each green pixel's brightness data consists of these 8 bits pixel data.
G6	GreenData 6	
G5	GreenData 5	
G4	GreenData 4	
G3	GreenData 3	
G2	GreenData 2	
G1	GreenData 1	
G0	GreenData 0 (LSB)	
B7	Blue Data 7 (MSB)	Blue-pixel Data Each blue pixel's brightness data consists of these 8 bits pixel data.
B6	Blue Data 6	
B5	Blue Data 5	
B4	Blue Data 4	
B3	Blue Data 3	
B2	Blue Data 2	
B1	Blue Data 1	
B0	Blue Data 0 (LSB)	
RxCLKIN+	LVDS Clock Input	
RxCLKIN-		
DE	Display Enable	
VS	Vertical Sync	
HS	Horizontal Sync	

Note: Output signals from any system shall be low or Hi-Z state when VDD is off.

6.5 Interface Timing

6.5.1 Timing Characteristics

DE mode only

Parameter	Symbol	Min.	Typ.	Max.	Unit	Condition
Clock frequency	$1/T_{\text{Clock}}$	33.6	39.8	48.3	MHz	
Vertical Section	Period	T_V	608	628	650	T_H
	Active	T_{VD}	600	600	600	
	Blanking	T_{VB}	8	28	50	
Horizontal Section	Period	T_H	920	1056	1240	T_{Clock}
	Active	T_{HD}	800	800	800	
	Blanking	T_{HB}	120	256	440	

Note: Frame rate is 60 Hz.

Note: DE mode.

6.5.2 Input Timing Diagram

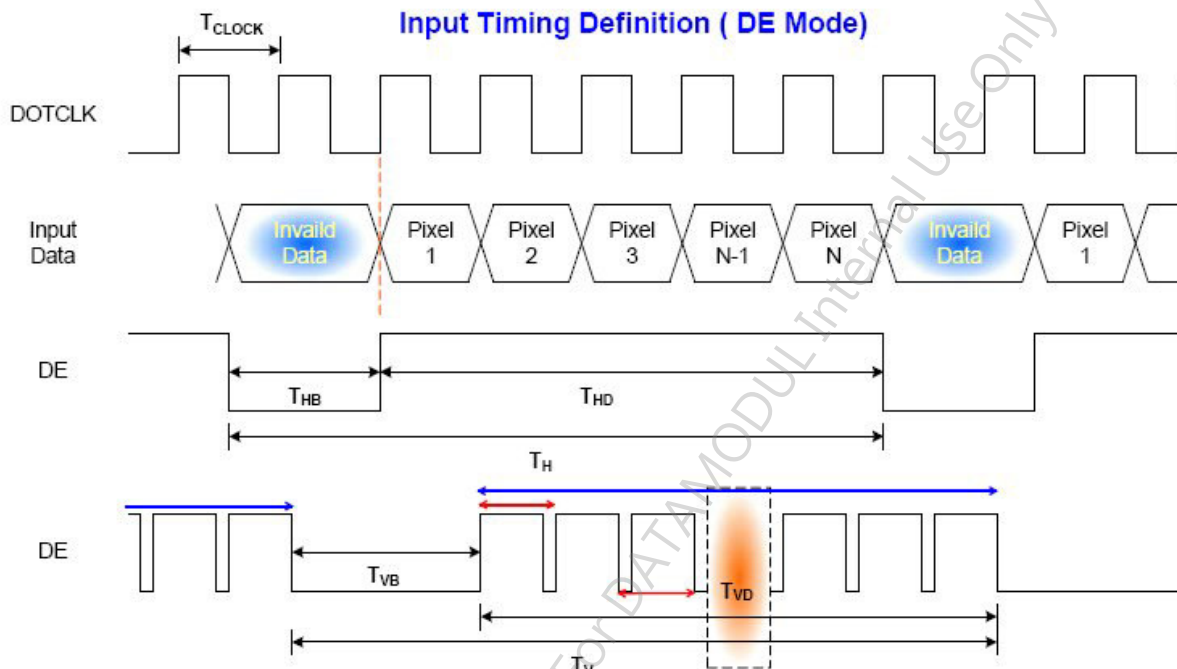

6.6 Power ON/OFF Sequence

VDD power and BL on/off sequence is as below. Interface signals are also shown in the chart. Signals from any system shall be Hi-Z state or low level when VDD is off.

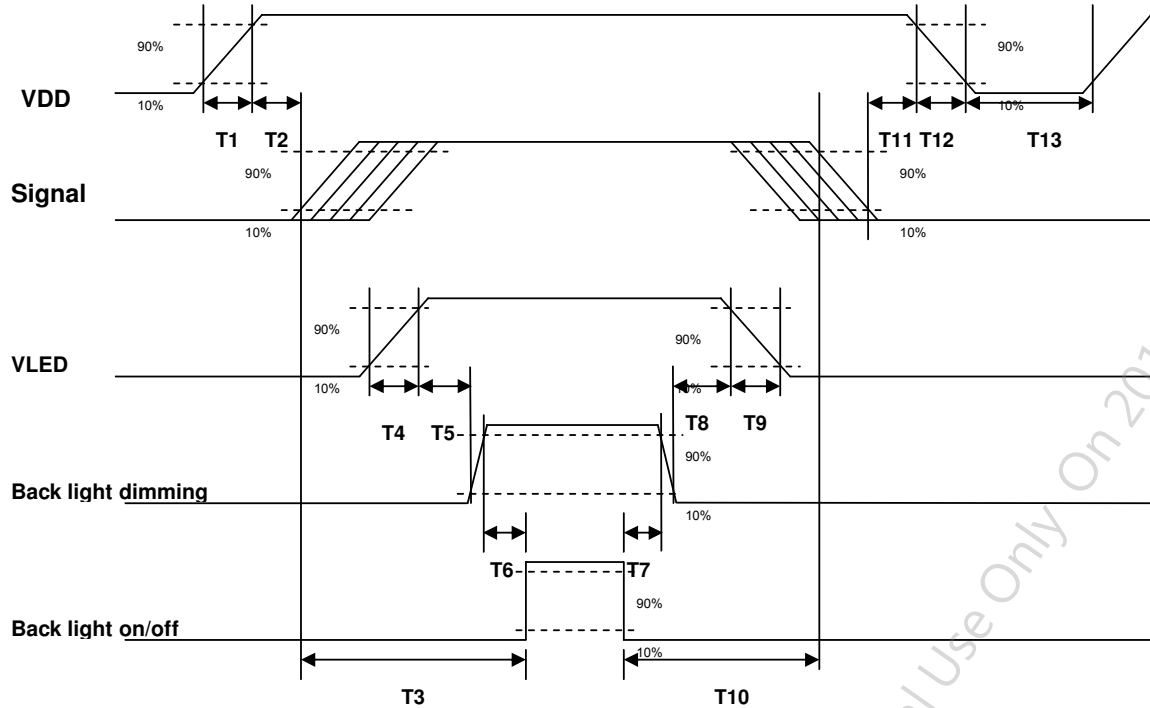

Power ON/OFF sequence timing

Parameter	Value			Units
	Min.	Typ.	Max.	
T1	0.5	-	10	[ms]
T2	30	40	50	[ms]
T3	200	-	-	[ms]
T4	0.5	-	10	[ms]
T5	10	-	-	[ms]
T6	10	-	-	[ms]
T7	0	-	-	[ms]
T8	10	-	-	[ms]
T9	-	-	10	[ms]
T10	110	-	-	[ms]
T11	0	16	50	[ms]
T12	-	-	10	[ms]
T13	1000	-	-	[ms]

The above on/off sequence should be applied to avoid abnormal function in the display. Please make sure to turn off the power when you plug the cable into the input connector or pull the cable out of the connector.

7. Connector & Pin Assignment

Physical interface is described as for the connector on module. These connectors are capable of accommodating the following signals and will be following components.

7.1 TFT LCD Module: LVDS Connector

Connector Name / Designation	Signal Connector
Manufacturer	STM or compatible.
Connector Model Number	MSB24013P20 or compatible.
Adaptable Plug	P24013P20 or compatible.

Pin No.	Signal Name	Pin No.	Signal Name
1	VDD	2	VDD
3	UD	4	LR
5	RxIN1-	6	RxIN1+
7	GND	8	RxIN2-
9	RxIN2+	10	GND
11	RxIN3-	12	RxIN3+
13	GND	14	RxCKIN-
15	RxCKIN+	16	GND
17	SEL 68	18	NC
19	RxIN4-	20	RxIN4+

7.2 Backlight Unit(CN2): LED Driver Connector

Connector Name / Designation	LED Connector
Manufacturer	ENTERY or compatible.
Connector Model Number	ENTERY 3808K-F04N-02R or compatible.
Mating Model Number	ENTERY H208K-P04N-02B or compatible.

Pin #	Symbol	Pin Description
1	VCC	12V input
2	GND	GND
3	Display_ON/OFF	+5.0V or +3.3 V:ON, 0V:OFF
4	Dimming	PWM

7.3 LED Light Bar Input Connector (CN3):

Connector Name / Designation	LED Connector
Manufacturer	ENTERY or compatible.
Connector Model Number	ENTERY H208K-P04N-02B or compatible.
Mating Model Number	ENTERY 3808K-F04N-02R or compatible.

Pin #	Symbol	Pin Description
1	VOUT	High voltage
2	FB1	Low voltage
3	FB2	Low voltage
4	FB3	Low voltage

Pin #	Symbol	Cable color
1	VOUT	Red
2	FB1	Black
3	FB2	Gray
4	FB3	White

AUO Confidential For DATAMODUL Internal Use Only On 2014/07/09

8. Reliability Test Criteria

Items	Required Condition	Note
Temperature Humidity Bias	40°C/90%,300 hours	
High Temperature Operation	70°C,300 hours	
Low Temperature Operation	-20°C,300 hours	
Hot Storage	70°C,300 hours	
Cold Storage	-20°C,300 hours	
Thermal Shock Test	-20°C/30 min ,60°C/30 min ,100cycles	
Shock Test (Non-Operating)	50G,20ms,Half-sine wave,(±X, ±Y, ±Z)	
Vibration Test (Non-Operating)	1.5G, (10~200Hz, P-P) 30 mins/axis (X, Y, Z)	
On/off test	On/10 sec, Off/10 sec, 30,000 cycles	
ESD	Contact Discharge: ± 8KV, 150pF(330Ω) 1sec, 8 points, 25 times/ point Air Discharge: ± 15KV, 150pF(330Ω) 1sec, 8 points, 25 times/ point	Note 1

Note1: According to EN61000-4-2, ESD class B: Some performance degradation allowed. No data lost

- Self-recoverable. No hardware failures.



9. Mechanical Characteristics

9.1 LCM Front View

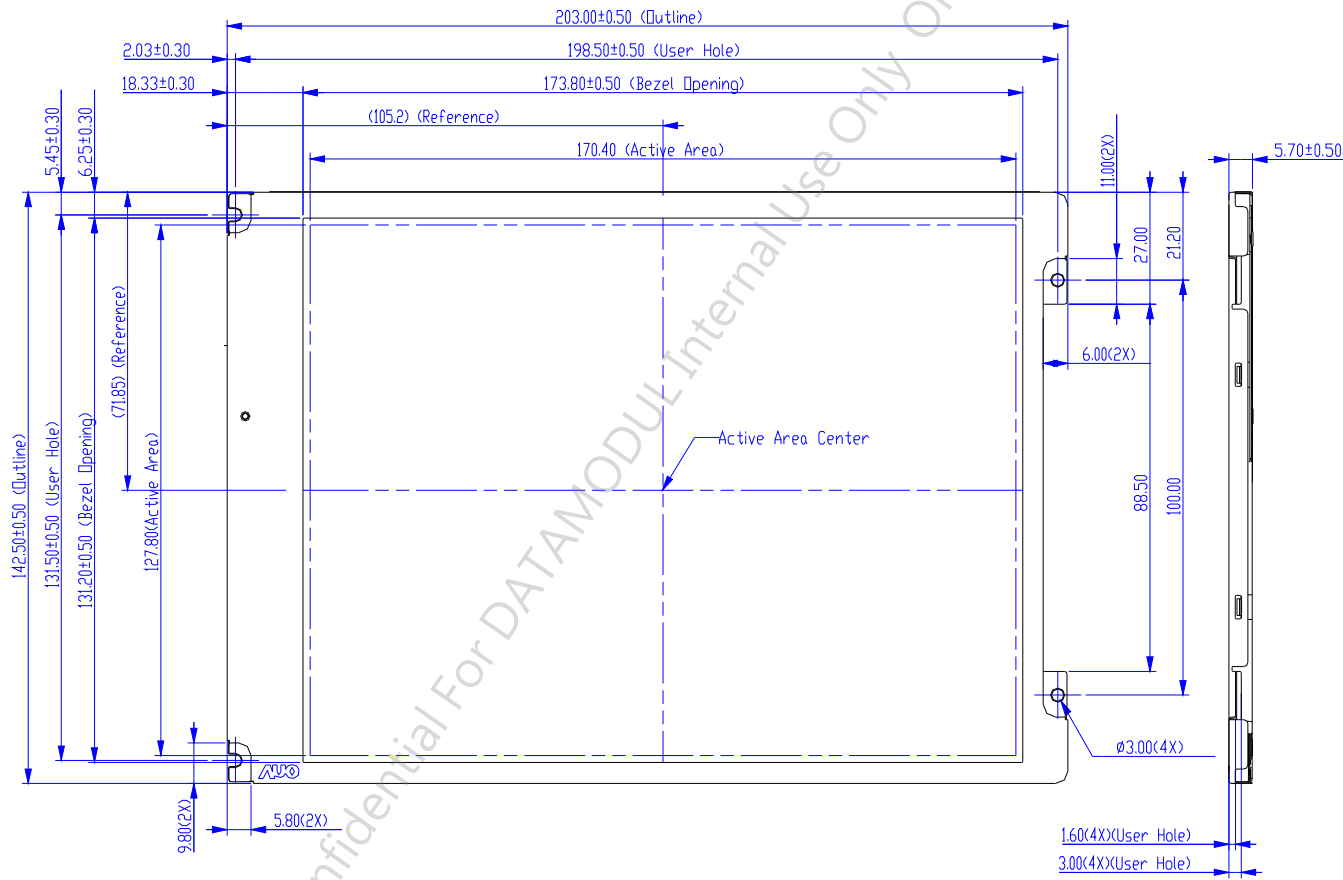



G084SN03 V3

9.2 LCM Rear View

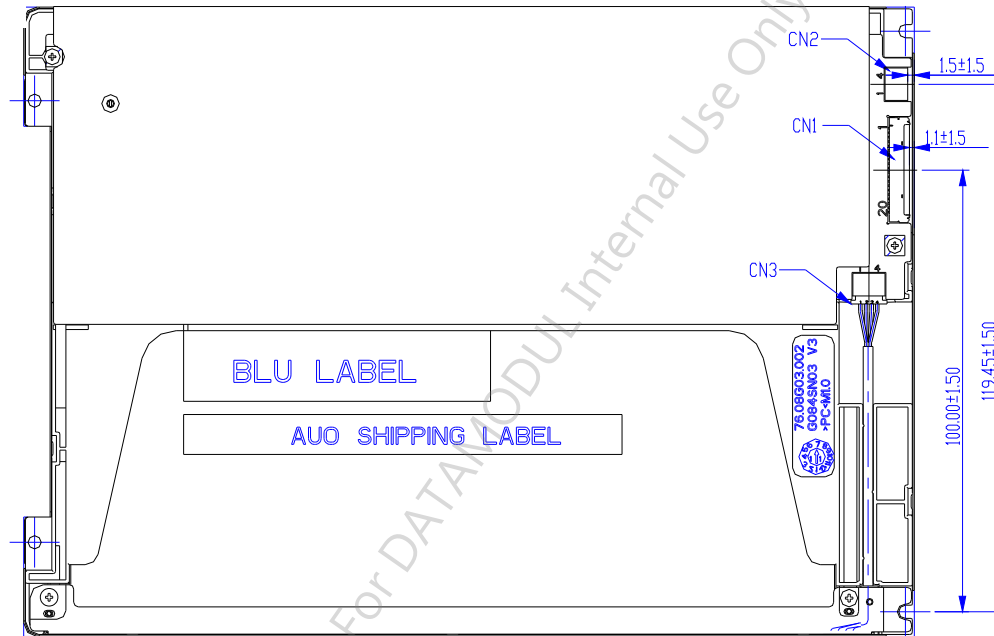

NOTE: Reminding to check screw's torque value before fastening panel.

1.CN1: THE INTERFACE CONNECTOR IS DF19K-20P-1H (HRS) OR AUO APPROVED EQUIVALENT.
CN2: THE LED CONNECTOR IS ENTERY 3808K-F04N-02R OR AUO APPROVED EQUIVALENT.
CN3: THE LED CONNECTOR IS ENTERY H208K-P04N-02B OR AUO APPROVED EQUIVALENT.
2.TOLERANCE IS ±0.5mm IF NOT SPECIFIED.

G084SN03 V3 rev. 2.0

24/26

10. Label and Packaging

10.1 Shipping Label (on the rear side of TFT-LCD display)



10.2 Carton Package

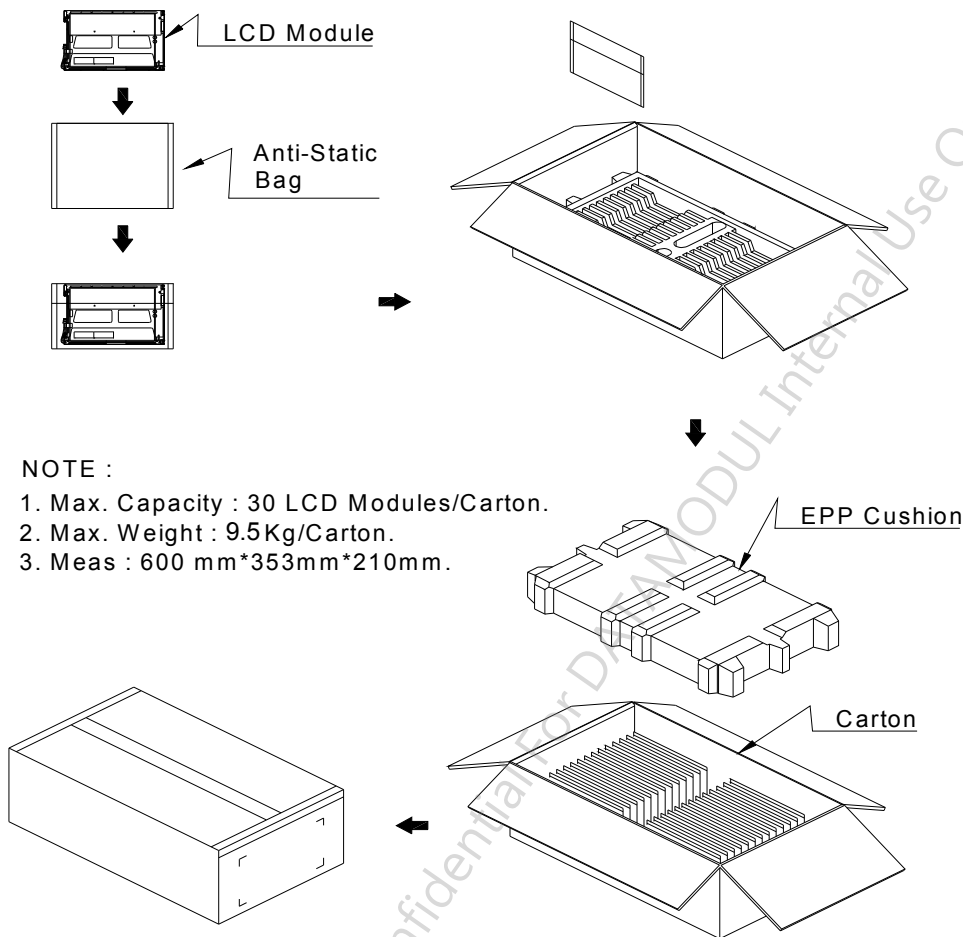

11 Safety

11.1 Sharp Edge Requirements

There will be no sharp edges or corners on the display assembly that could cause injury.

11.2 Materials

11.2.1 Toxicity

There will be no carcinogenic materials used anywhere in the display module. If toxic materials are used, they will be reviewed and approved by the responsible AUO toxicologist.

11.2.2 Flammability

All components including electrical components that do not meet the flammability grade UL94-V1 in the module will complete the flammability rating exception approval process.

The pRxINted circuit board will be made from material rated 94-V1 or better. The actual UL flammability rating will be pRxINted on the pRxINted circuit board.

11.3 Capacitors

If any polarized capacitors are used in the display assembly, provisions will be made to keep them from being inserted backwards.

11.4 National Test Lab Requirement

The display module will satisfy all requirements for compliance to:

UL 1950, First Edition

U.S.A. Information Technology Equipment



ALL TECHNOLOGIES. ALL COMPETENCIES. ONE SPECIALIST.

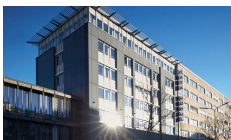

DATA MODUL AG
Landsberger Straße 322
DE-80687 Munich
Phone: +49-89-56017-0

DATA MODUL WEIKERSHEIM GMBH
Lindenstraße 8
DE-97990 Weikersheim
Phone: +49-7934-101-0



More information and worldwide locations can be found at

www.data-modul.com