

Specification

G104VAN01.0

10.4" - 640x480 – LVDS

Spec Revision: 0.0
Revision Date: 13.03.2024

Note: This specification is subject to change without prior notice



- (V) Preliminary Specifications
- () Final Specifications

Module	10.4 Inch Color TFT-LCD
Model Name	G104VAN01.0

Customer	Date
Checked & Approved by	
_____	_____

Note: This Specification is subject to change without notice.

Approved by	Date
_____	_____
Prepared by	
_____ Grey Lin	_____ 2024/09/12

General Display Business Division / AU Optronics corporation

Contents

1. Operating Precautions	4
2. General Description	5
2.1 Display Characteristics.....	5
2.2 Optical Characteristics	6
3. Functional Block Diagram.....	9
4. Absolute Maximum Ratings.....	10
4.1 Absolute Ratings of TFT LCD Module.....	10
4.2 Absolute Ratings of Environment.....	10
5. Electrical Characteristics	11
5.1 TFT LCD Module.....	11
6. Signal Characteristics	14
6.1 Pixel Format Image.....	14
6.2 Scanning Direction.....	14
6.3 TFT-LCD Interface Signal Description.....	15
6.4 The Input Data Format.....	16
6.5 TFT-LCD Interface Timing.....	17
6.6 Power ON/OFF Sequence	18
7. Connector & Pin Assignment	19
7.1 TFT-LCD Signal (CN1): LCD Connector	19
7.2 LED Backlight Unit (CN2): Backlight Connector.....	19
7.3 LED Backlight Unit (CN4): Light bar Connector	19
8. Reliability Test Criteria (Follow G104VN 01 V1).....	20
9. Mechanical Characteristics.....	21
9.1 LCM Outline Dimension (Front View).....	21
9.2 LCM Outline Dimension (Rear View)	22



Record of Revision

Version and Date	Page	Old description	New Description
0.0 2024/03/13	All	First Edition	

ADP confidential for Data Modul use only

1. Operating Precautions

- 1) Since front polarizer is easily damaged, please be cautious and not to scratch it.
- 2) Be sure to turn off power supply when inserting or disconnecting from input connector.
- 3) Wipe off water drop immediately. Long contact with water may cause discoloration or spots.
- 4) When the panel surface is soiled, wipe it with absorbent cotton or soft cloth.
- 5) Since the panel is made of glass, it may be broken or cracked if dropped or bumped on hard surface.
- 6) To avoid ESD (Electro Static Discharge) damage, be sure to ground yourself before handling TFT-LCD Module.
- 7) Do not open nor modify the module assembly.
- 8) Do not press the reflector sheet at the back of the module to any direction.
- 9) In case if a module has to be put back into the packing container slot after it was taken out from the container, do not press the center of the LED light bar edge. Instead, press at the far ends of the LED light bar edge softly. Otherwise the TFT Module may be damaged.
- 10) At the insertion or removal of the Signal Interface Connector, be sure not to rotate nor tilt the Interface Connector of the TFT Module.
- 11) TFT-LCD Module is not allowed to be twisted & bent even force is added on module in a very short time. Please design your display product well to avoid external force applying to module by end-user directly.
- 12) Small amount of materials without flammability grade are used in the TFT-LCD module. The TFT-LCD module should be supplied by power complied with requirements of Limited Power Source (IEC60950 or UL1950), or be applied exemption.
- 13) Severe temperature condition may result in different luminance, response time and lamp ignition voltage.
- 14) Continuous operating TFT-LCD display under low temperature environment may accelerate lamp exhaustion and reduce luminance dramatically.
- 15) The data on this specification sheet is applicable when LCD module is placed in landscape position.
- 16) Continuous displaying fixed pattern may induce image sticking. It's recommended to use screen saver or shuffle content periodically if fixed pattern is displayed on the screen.



2. General Description

This specification applies to the Color Active Matrix Liquid Crystal Display G104VAN01.0 composed of a TFT-LCD display, a driver and power supply circuit, and a LED backlight system. The screen format is intended to support VGA (640(H) x 480(V)) screen and 16.2M (RGB 8-bits) or 262k colors (RGB 6-bits).

All input signals are LVDS interface and compatible with G104VN01 V1.

G104VAN01.0 designed with wide viewing angle; wide temperature and long life LED backlight is well suited for industrial applications.

2.1 Display Characteristics

The following items are characteristics summary on the table under 25 °C condition:

Items	Unit	Specifications
Screen Diagonal	[inch]	10.4
Active Area	[mm]	211.2 (H) x 158.4 (V)
Pixels H x V		640 x 3(RGB) x 480
Pixel Pitch	[mm]	0.33 x 0.33
Pixel Arrangement		R.G.B. Vertical Stripe
Display Mode		AHVA, Normally Black
Nominal Input Voltage VDD	[Volt]	3.3 (typ.)
Typical Power Consumption	[Watt]	(3.33W(typ.)) All white pattern (Note 1)
Weight	[Grams]	TBD
Physical Size	[mm]	243.0(H) x 176.6(V) x 8.0(D) (typ.)
Electrical Interface		1 channel LVDS
Surface Treatment		Anti-glare, Hardness 3H
Support Color		16.2M / 262K colors
Temperature Range Operating Storage (Non-Operating)	[°C] [°C]	-30 to +85 -30 to +85
RoHS Compliance		RoHS Compliance

Note 1: This value is accumulated value, the accurate values need to measure with first sample.

2.2 Optical Characteristics

The optical characteristics are measured under stable conditions at 25°C (Room Temperature):

Item	Unit	Conditions	Min.	Typ.	Max.	Remark
White Luminance	[cd/m ²]	I _F = (48mA/1 LED) Line (center point)	330	450	-	Note 2
Uniformity	%	5 Points	75	-	-	Note 3, 4
Contrast Ratio			700	1000	-	Note 5
Response Time	[msec]	Rising	-	20	30	Note 6
	[msec]	Falling	-	10	20	
	[msec]	Raising + Falling	-	30	50	
Viewing Angle	[degree] [degree]	Horizontal (Right) CR = 10 (Left)	80 80	89 89	- -	Note 7
	[degree] [degree]	Vertical (Upper) CR = 10 (Lower)	80 80	89 89	- -	
Color / Chromaticity Coordinates (CIE 1931)		Red x	TBD	TBD	TBD	Note 1
		Red y	TBD	TBD	TBD	
		Green x	TBD	TBD	TBD	
		Green y	TBD	TBD	TBD	
		Blue x	TBD	TBD	TBD	
		Blue y	TBD	TBD	TBD	
		White x	(0.263)	0.313	(0.363)	
	White y	(0.279)	0.329	(0.379)		
Color Gamut	%		-	45	-	

Note 1: This value is accumulated value, the accurate values need to measure with first sample.

Note 2: Measurement method

Equipment Pattern Generator, Power Supply, Digital Voltmeter, Luminance meter (SR_3 or equivalent)

Aperture Field angle 2° with 50cm measuring distance

Test Point Follow Note 2 position

Environment < 1 lux

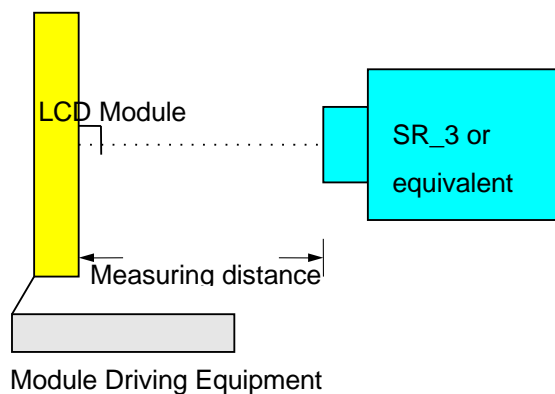

Note 3: Definition of 5 points position (Display active area: 211.2mm (H) x 158.4mm (V))

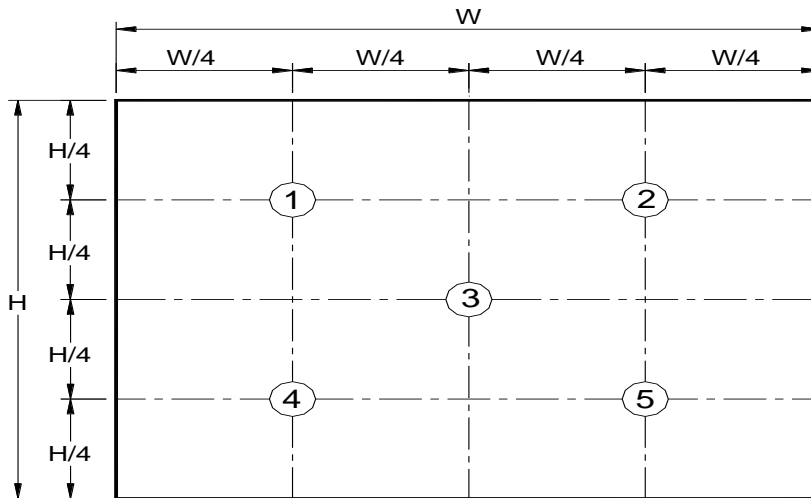

Note 4: The luminance uniformity of 5 points is defined by dividing the minimum luminance values by the maximum test point luminance

$$\delta_{w9} = \frac{\text{Minimum Brightness of five points}}{\text{Maximum Brightness of five points}}$$

Note 5: Definition of contrast ratio (CR):

$$\text{Contrast ratio (CR)} = \frac{\text{Brightness on the "White" state}}{\text{Brightness on the "Black" state}}$$

Note 6: Definition of response time:

The output signals of photo detector are measured when the input signals are changed from "White" to "Black" (falling time) and from "Black" to "White" (rising time), respectively. The response time interval is between 10% and 90% of amplitudes. Please refer to the figure as below.

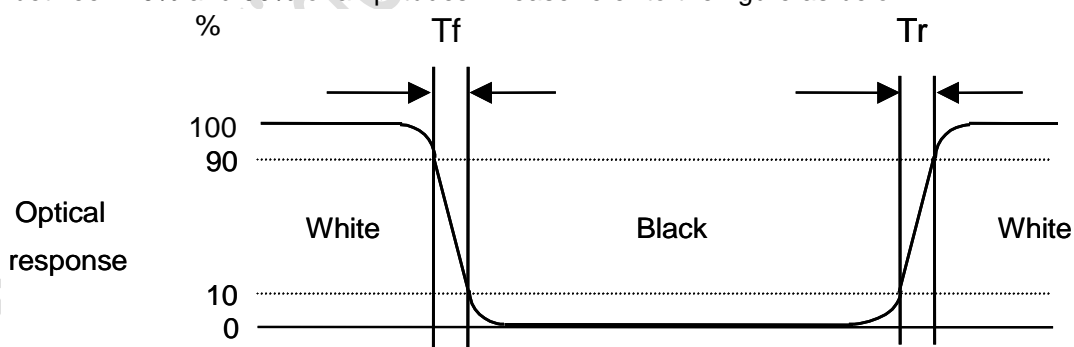

Note 7: Definition of viewing angle

Viewing angle is the measurement of contrast ratio ≥ 10 , at the screen center, over a 180° horizontal and 180° vertical range (off-normal viewing angles). The 180° viewing angle range is broken down as below: 90° (θ) horizontal left and right, and 90° (Φ) vertical high (up) and low (down). The measurement direction

is typically perpendicular to the display surface with the screen rotated to its center to develop the desired measurement viewing angle.

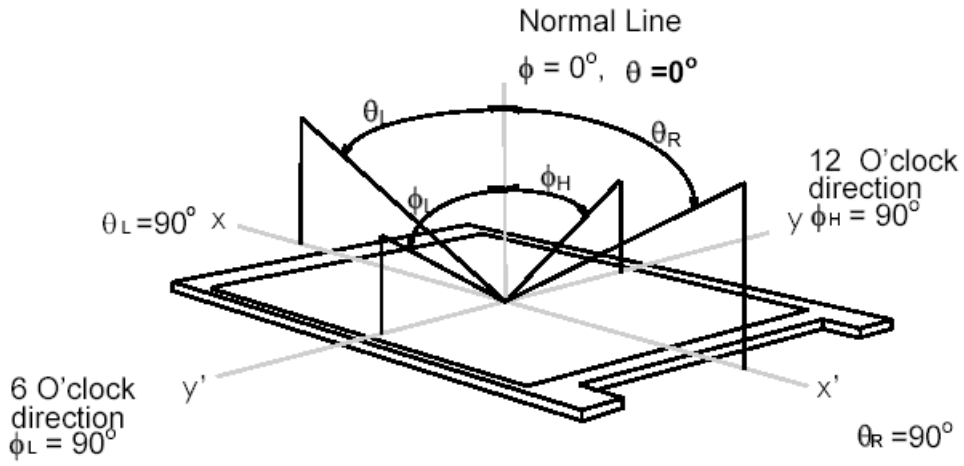

only

ADP confidential for Data M...

3. Functional Block Diagram

The following diagram shows the functional block of the 10.4 inch color TFT/LCD module:

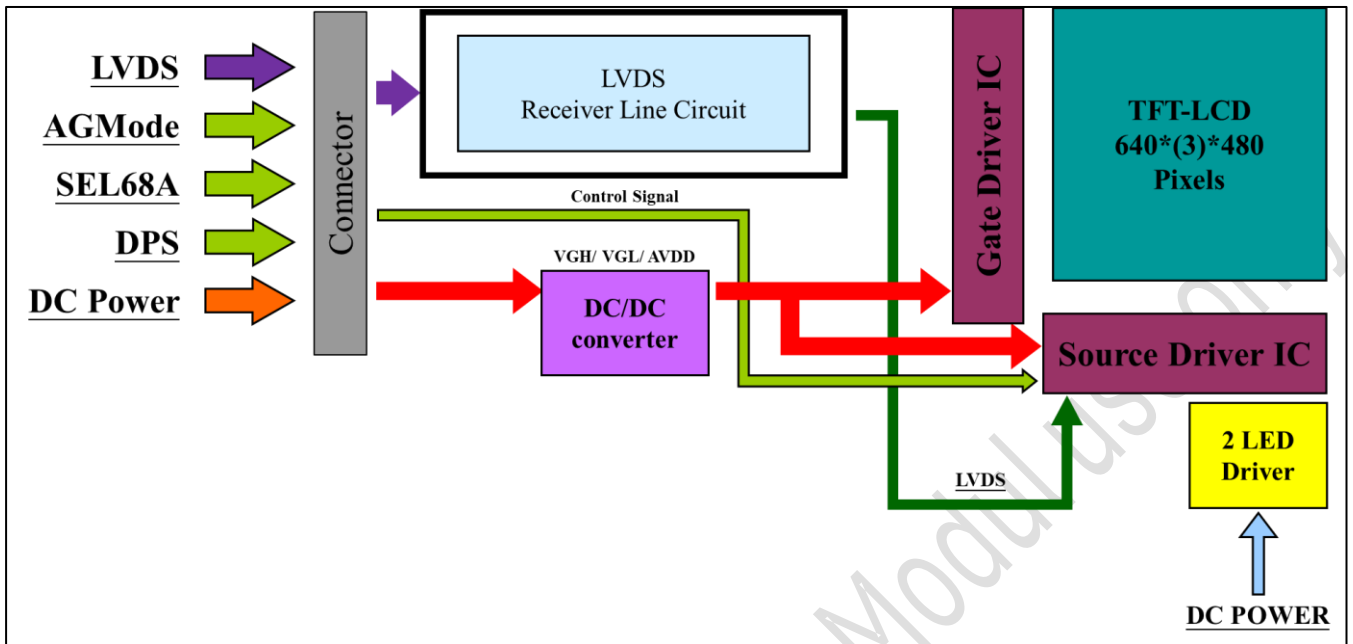

Note1: The Gamma Voltage is expected to combined into Source Drive IC.

4. Absolute Maximum Ratings

4.1 Absolute Ratings of TFT LCD Module

Item	Symbol	Min	Max	Unit
Logic/LCD Drive Voltage	VDD	-0.3	4	[Volt]
Reverse Scan Function	DPS	-0.3	4	[Volt]
6/8 bit LVDS Input	SEL68	-0.3	4	[Volt]
LED Input Voltage	LED_VCC	-0.3	25	[Volt]
LED Control Signal	LED_PWM	-0.3	6	[Volt]
LED Control Signal	LED_EN	-0.3	6	[Volt]

4.2 Absolute Ratings of Environment

Item	Symbol	Min	Max	Unit
Operating Temperature	TOP	-30	+85	[°C]
Operation Humidity	HOP	5	95	[%RH]
Storage Temperature	TST	-30	+85	[°C]
Storage Humidity	HST	5	95	[%RH]

Note 1: Maximum Wet-Bulb should be 39°C and no condensation.

Note 2: Only operation is guaranteed. Optical and display performance should be evaluated at 25°C only.

Note 3: Permanent damage to the device may occur if exceed maximum values.

Note 3: Symbol (*) means panel surface temperature on LCD panel.

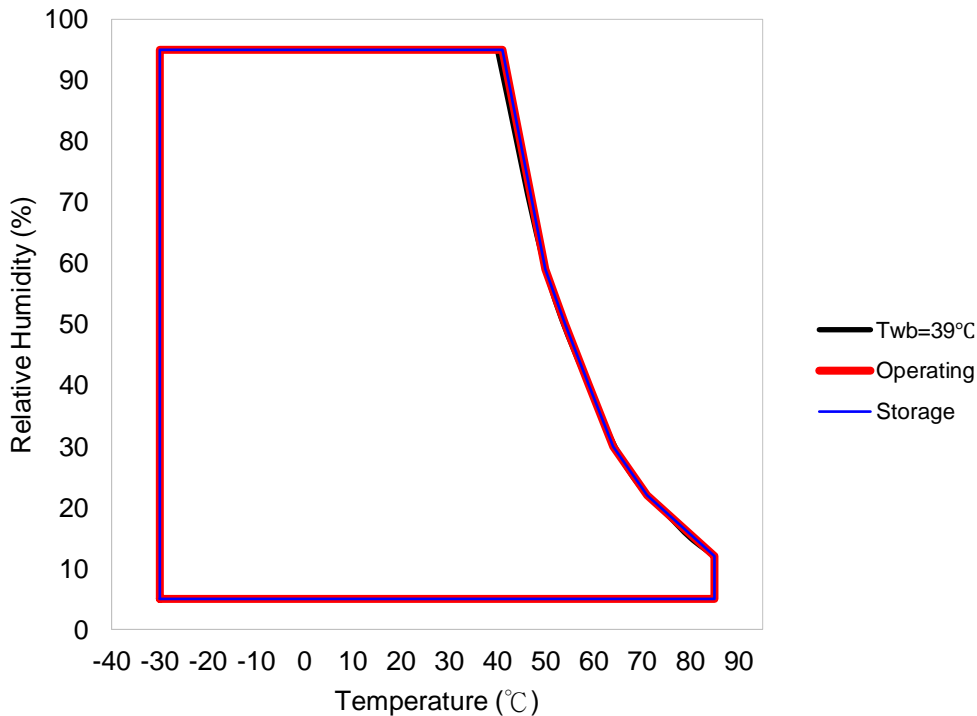

5. Electrical Characteristics

5.1 TFT LCD Module

5.1.1 Power Specification

Symbol	Parameter	Min	Typ	Max	Units	Remark
VDD	Logic/LCD Input Voltage	3.0	3.3	3.6	[Volt]	
I _{VDD}	LCD Input Current	-	(155) Note 1	-	[mA]	VDD=3.3V at 60 HZ, all white Pattern
P _{VDD}	LCD Power consumption	-	(0.51) Note 1	-	[Watt]	VDD=3.3V at 60 HZ, all white Pattern
I _{rush LCD}	LCD Inrush Current	-	-	1.5	[A]	Note 1; VDD=3.3V Black Pattern, Rising time=470us
VDD _{rp}	Allowable Logic/LCD Drive Ripple Voltage	-	-	100	[mV] p-p	VDD=3.3V at 60 HZ, all Black Pattern
SEL68	6/8 bit LVDS Input Selection	High Level	(2.8) Note 1	-	(VDD) Note 1	[Volt]
		Low Level	0	-	0.8	[Volt]
DPS	Reverse Scan Function	High Level	(2.8) Note 1	-	(VDD) Note 1	[Volt]
		Low Level	0	-	0.8	[Volt]

Note 1: This value is accumulated value, the accurate values need to measure with first sample.

Note 2: Measurement condition:

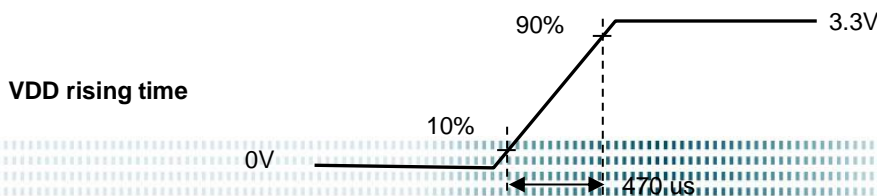
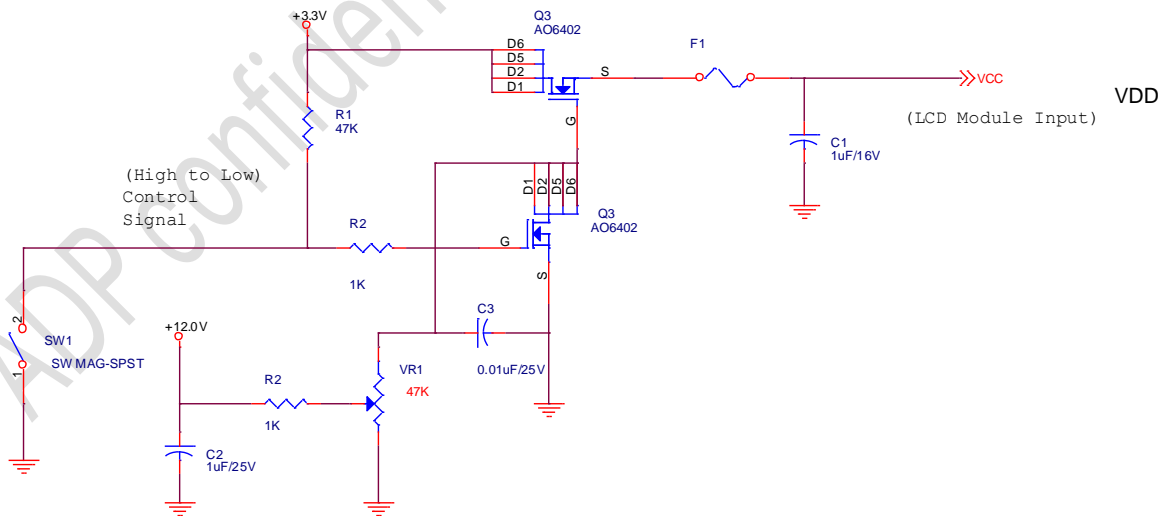

5.1.2 Signal Electrical Characteristics

Symbol	Item	Min.	Typ.	Max.	Unit	Remark
V_{th}	Differential Input High Threshold	-	-	100	[mV]	VCM=1.2V
V_{tl}	Differential Input Low Threshold	100	-	-	[mV]	VCM=1.2V
V_{ID}	Input Differential Voltage	100	400	600	[mV]	
V_{cm}	Differential Input Common Mode Voltage	1.1	-	1.45	[V]	VTH/VTL=±100mV

Input signals shall be low or Hi-Z state when VDD is off.

Note: LVDS Signal Waveform.

Single-end Signal

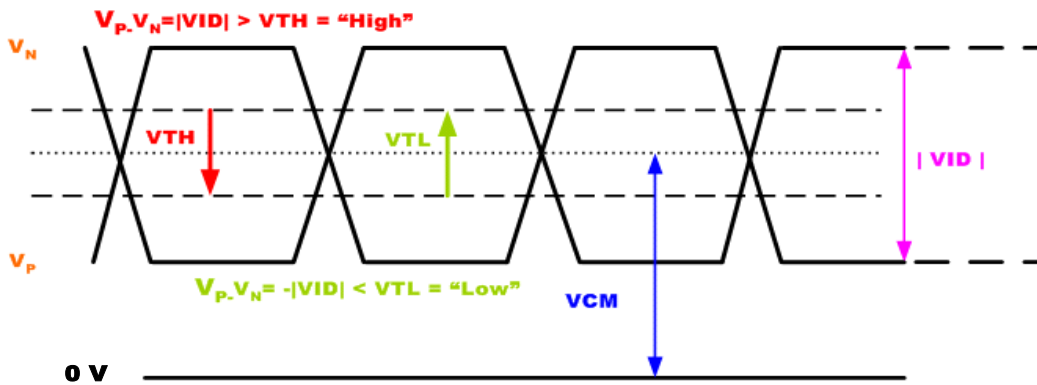

Differential Signal

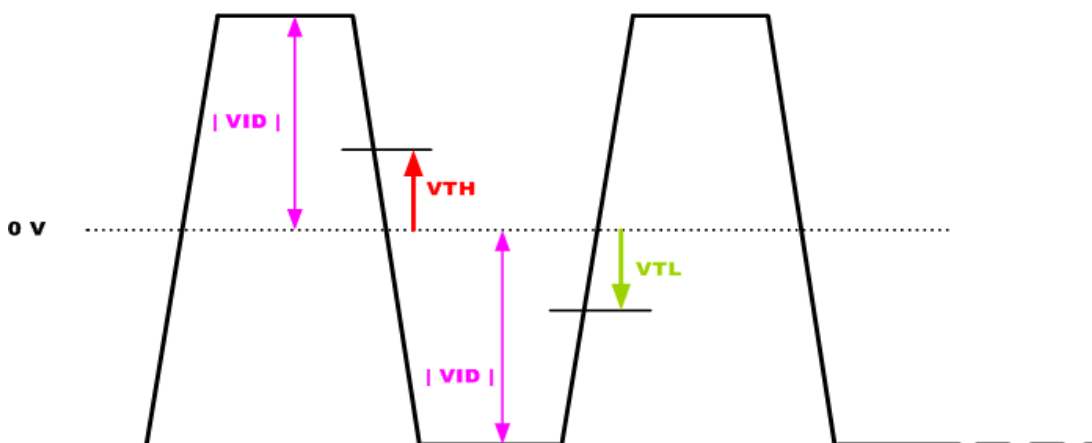

5.2 Backlight Unit

5.2.1 Parameter guideline for LCD

Following characteristics are measured under a stable condition using an inverter at 25°C. (Room Temperature):

Symbol	Parameter		Min.	Typ.	Max.	Unit	Remark
LED_VCC	Input Voltage		10.8	12	13.2	[Volt]	
I_{rush LED}	Inrush Current		-	-	1.5	[A]	
I_{VCC}	Input Current		-	(0.235) Note 1		[A]	100% PWM Duty (LED_VCC=12V)
P_{LED}	Power Consumption		-	(2.82) Note 1		[Watt]	100% PWM Duty (LED_VCC=12V)
LED_EN	EN Control Level	BL On	3	(5) Note 1	5.5	[Volt]	Backlight On/Off
		BL Off	0	-	(0.5) Note 1		
F_{LED_PWM}	PWM Control Frequency		200	-	20K	[Hz]	PWM Control
D_{LED_PWM}	PWM Control Duty Ratio		5	-	100	[%]	
V_{LED_PWM}	PWM Control Level	High Level	3	5	5.5	[Volt]	
		Low Level	0	-	(0.5) Note 1		
I_F	LED Forward Current		-	(48) Note 1	-	[mA]	Ta = 25°C
V_F	LED Forward Voltage		-	(25.6) Note 1	-	[Volt]	I _F = (48)mA, Ta= -30°C
			-	(24) Note 1	(26.4) Note 1	[Volt]	I _F = (48)mA, Ta= 25°C
			-	(22.4) Note 1	-	[Volt]	I _F = (48)mA, Ta= 85°C
P_{LED}	LED Power Consumption		-	(2.4) Note 1	-	[Watt]	
Operation Life			70,000	-	-	Hrs	I _F =80mA, Ta= 25°C

Note 1: This value is accumulated value, the accurate values need to measure with first sample.

Note 2: Ta means ambient temperature of TFT-LCD module.

Note 3: VCC, I_{VCC}, I_{rush LED}, P_{VCC} are defined for LED backlight.(100% duty of PWM dimming)

Note 4: I_F, V_F are defined for one channel LED. There are two LED channel in back light unit.

Note 5: If G104VAN01.0 module is driven by high current or at high ambient temperature & humidity condition. The operating life will be reduced.

Note 6: Operating life means brightness goes down to 50% initial brightness. Minimum operating life time is estimated data.

Note 7: LED combination: 2 series 8 parallel.

6. Signal Characteristics

6.1 Pixel Format Image

Following figure shows the relationship between input signal and LCD pixel format.

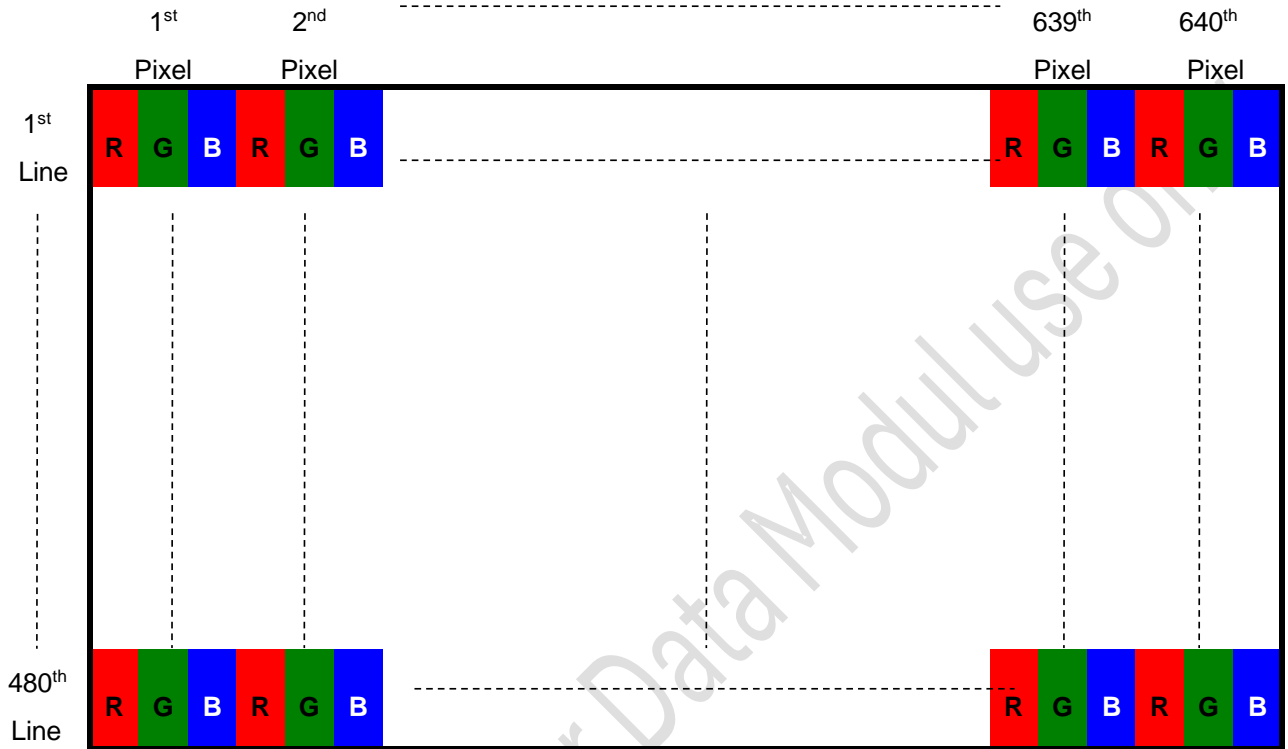

6.2 Scanning Direction

The following figures show the image seen from the front view. The arrow indicates the direction of scan.

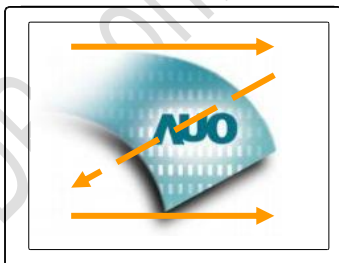

Fig. 1 Normal scan (Pin4, DPS = Low or NC)

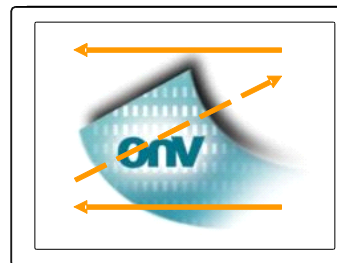

Fig. 2 Reverse scan (Pin4, DPS = High)

6.3 TFT-LCD Interface Signal Description

The module using a LVDS receiver embaded in AUO's ASIC. LVDS is a differential signal technology for LCD interface and a high-speed data transfer device.

Input Signal Interface		
Pin No.	Symbol	Description
1	VDD	Power Supply, 3.3V (typical)
2	VDD	Power Supply, 3.3V (typical)
3	GND	Ground
4	DPS	Reverse Scan Function [H: Enable; L/NC: Disable]
5	RxIN0-	LVDS receiver signal channel 0
6	RxIN0+	LVDS Differential Data Input (R0, R1, R2, R3, R4, R5, G0)
7	GND	Ground
8	RxIN1-	LVDS receiver signal channel 1
9	RxIN1+	LVDS Differential Data Input (G1, G2, G3, G4, G5, B0, B1)
10	GND	Ground
11	RxIN2-	LVDS receiver signal channel 2
12	RxIN2+	LVDS Differential Data Input (B2, B3, B4, B5, HS, VS, DE)
13	GND	Ground
14	RxCLKIN-	LVDS receiver signal clock
15	RxCLKIN+	
16	GND	Ground
17	RxIN3-	LVDS receiver signal channel 3, Pin17:VDD & PIN18: GND for 6 bit LVDS Input
18	RxIN3+	LVDS Differential Data Input (R6, R7, G6, G7, B6, B7, RSV)
19	RSV	Reserved for AUO internal test. Please treat it as NC.
20	SEL68	6/ 8bits LVDS data input selection [H: 8bits L: 6bit]

Note 1: Input Signals shall be in low status when VDD is off.

Note 2: High stands for "3.3V", Low stands for "0V", NC stands for "No Connection".

Note 3: RSV stands for "Reserved".

Note 4:

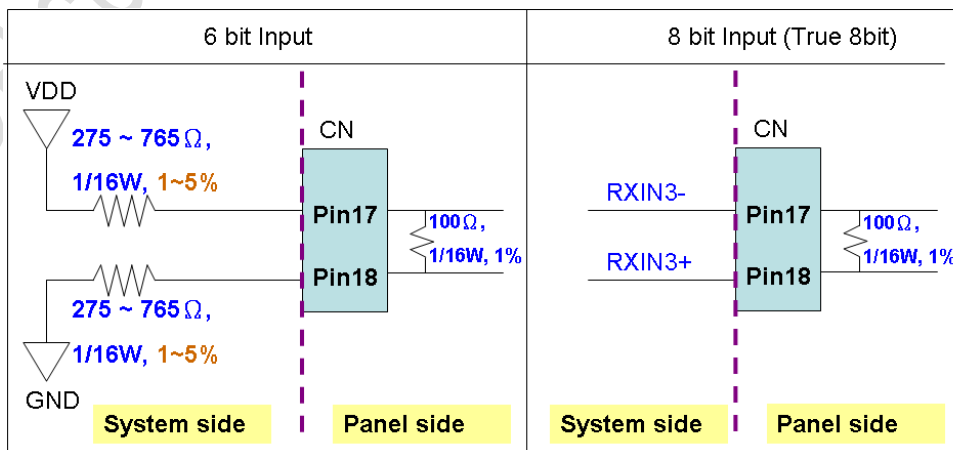

6.4 The Input Data Format

6.4.1 SEL68

SEL68 = "Low" for 6 bits LVDS Input

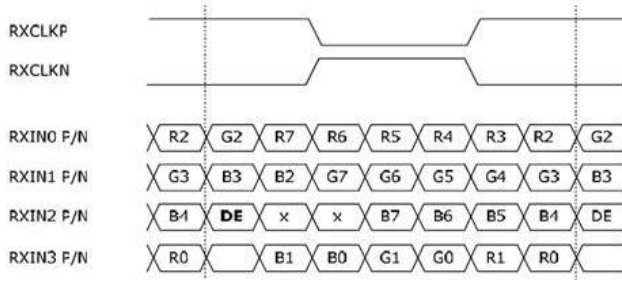

SEL68 = "High" or NC for 8 bits LVDS Input

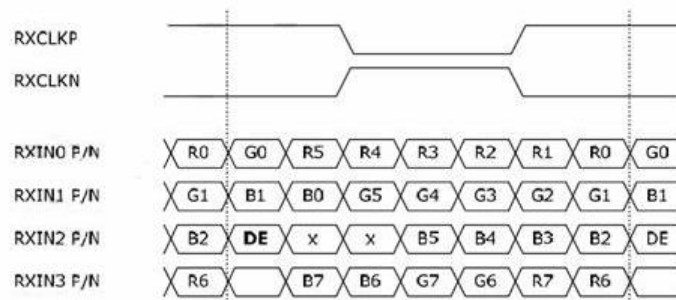

Note1: Please follow PSWG.

Note2: R/G/B data 7:MSB, R/G/B data 0:LSB

Signal Name	Description	Remark
R7	Red Data 7	Red-pixel Data
R6	Red Data 6	
R5	Red Data 5	
R4	Red Data 4	
R3	Red Data 3	
R2	Red Data 2	
R1	Red Data 1	
R0	Red Data 0	
G7	Green Data 7	Green-pixel Data
G6	Green Data 6	
G5	Green Data 5	
G4	Green Data 4	
G3	Green Data 3	
G2	Green Data 2	
G1	Green Data 1	
G0	Green Data 0	
B7	Blue Data 7	Blue-pixel Data
B6	Blue Data 6	
B5	Blue Data 5	
B4	Blue Data 4	
B3	Blue Data 3	
B2	Blue Data 2	
B1	Blue Data 1	
B0	Blue Data 0	
RxCLKIN	LVDS Data Clock	
DE	Data Enable Signal	When the signal is high, the pixel data shall be valid to be displayed.

Note: Output signals from any system shall be low or Hi-Z state when VDD is off.

6.5 TFT-LCD Interface Timing

6.5.1 Timing Characteristics

Signal	Symbol	Min.	Typ.	Max.	Unit	
Clock Frequency	$1/T_{\text{Clock}}$	(22.87)	25.2	28.33	MHz	
Vertical Section	Period	T_V	495	525	560	T_{Line}
	Active	T_{VD}	--	480	--	
	Blanking	T_{VB}	(15)	45	80	
Horizontal Section	Period	T_H	770	800	900	T_{Clock}
	Active	T_{HD}	--	640	--	
	Blanking	T_{HB}	130	160	260	

Note 1: This value is accumulated value, the accurate values need to measure with first sample.

Note 2: Frame rate is 60 Hz.

Note 3: DE mode.

6.5.2 Input Timing Diagram

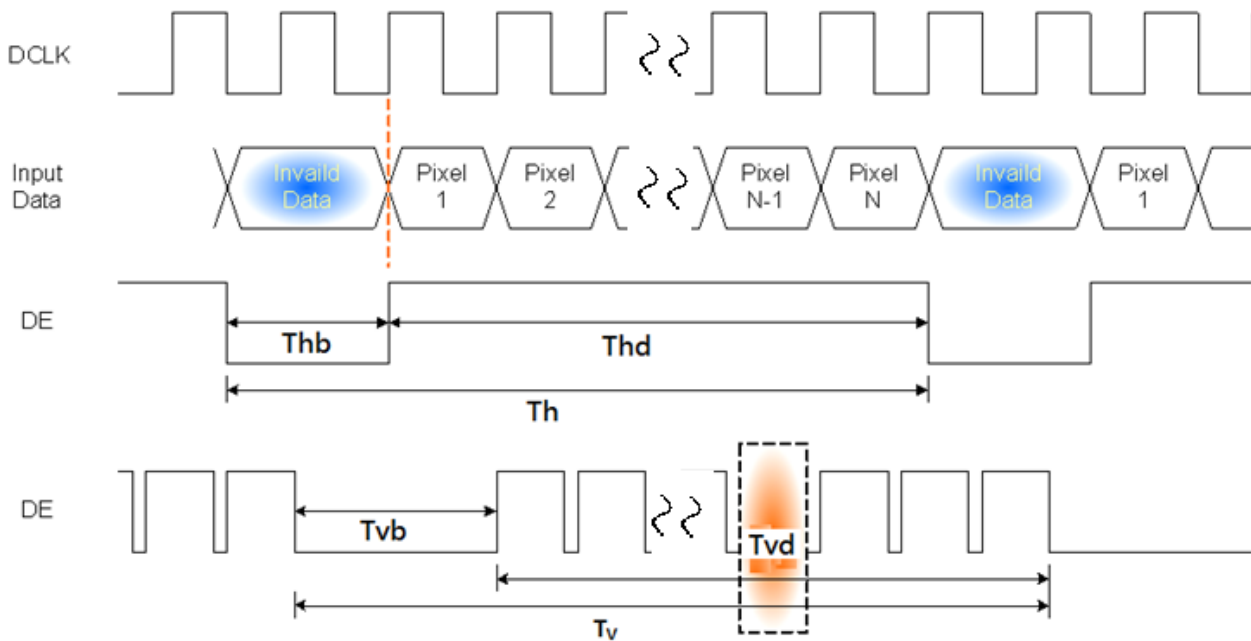

6.6 Power ON/OFF Sequence

VDD power and lamp on/off sequence is as below. Interface signals are also shown in the chart. Signals from any system shall be Hi-Z state or low level when VDD is off.

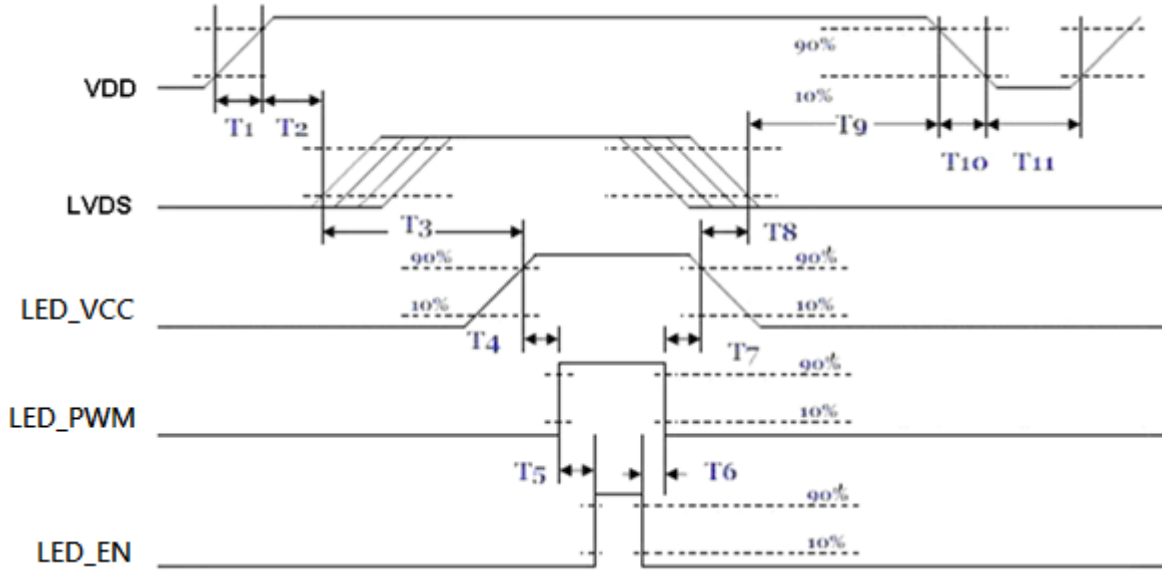

Power ON/OFF sequence timing

Parameter	Value			Units
	Min.	Typ.	Max.	
T1	0.5	-	10	[ms]
T2	30	40	50	[ms]
T3	450	-	-	[ms]
T4	10	-	-	[ms]
T5	10	-	-	[ms]
T6	0	-	-	[ms]
T7	10	-	-	[ms]
T8	100	-	-	[ms]
T9	0	16	50	[ms]
T10	-	-	10	[ms]
T11	1000	-	-	[ms]

The above on/off sequence should be applied to avoid abnormal function in the display. Please make sure to turn off the power when you plug the cable into the input connector or pull the cable out of the connector.

7. Connector & Pin Assignment

Physical interface is described as for the connector on module. These connectors are capable of accommodating the following signals and will be following components.

7.1 TFT-LCD Signal (CN1): LCD Connector

Connector Name / Designation	Signal Connector
Manufacturer	STM or compatible
Connector Model Number	MSB24013P20HA or compatible
Adaptable Plug	HRS DF19G-20S-1C(05) and DF19A-2830SCFA or compatible

Pin No.	Symbol	Pin No.	Symbol
1	VDD	2	VDD
3	GND	4	DPS
5	RxIN0-	6	RxIN0+
7	GND	8	RxIN1-
9	RxIN1+	10	GND
11	RxIN2-	12	RxIN2+
13	GND	14	RxCKIN-
15	RxCKIN+	16	GND
17	RxIN3-	18	RxIN3+
19	RSV	20	SEL68

7.2 LED Backlight Unit (CN2): Backlight Connector

Connector Name / Designation	Lamp Connector
Manufacturer	STM or compatible
Connector Model Number	MSB24038P5D or compatible
Mating Model Number	H208K-D05N-22B or compatible

Pin No.	symbol	description
Pin1	LED_VCC	12V input
Pin2	GND	GND
Pin3	LED_EN	Backlight ON/OFF
Pin4	LED_PWM	Backlight Dimming
Pin5	NA	

7.3 LED Backlight Unit (CN4): Light bar Connector

Connector Name / Designation	Lamp Connector
Manufacturer	ENTERY or compatible
Connector Model Number	MSB24038P3D or compatible
Mating Model Number(CN3)	H208K-P03N-02B or compatible

Pin No.	symbol	description	Color
Pin1	H	LED anode	Red
Pin2	L	LED cathode	White
Pin3	L	LED cathode	Black

8. Reliability Test Criteria (Follow G104VN 01 V1)

Items	Required Condition	Note
Temperature Humidity Bias	40°C, 90%RH, 300 hours	
High Temperature Operation	85°C, 300 hours	
Low Temperature Operation	-30°C, 300 hours	
Hot Storage	85°C, 300 hours	
Cold Storage	-30°C, 300 hours	
Thermal Shock Test	-20°C/ 30 min, 60°C/ 30 min, 100cycles, 40°C minimum ramp rate	
Hot Start Test	85°C / 1Hr min. power on/off per 5 minutes, 5 times	
Cold Start Test	-30°C / 1Hr min. power on/off per 5 minutes, 5 times	
Shock Test (Non-Operating)	50G, 20ms, Half-sine wave, (±X, ±Y, ±Z)	
Vibration Test (Non-Operating)	1.5G, (10~200Hz, Sine wave) 30 mins/axis, 3 direction (X, Y, Z)	
On/off test	On/10 sec, Off/10 sec, 30,000 cycles	
ESD	Contact Discharge: ± 8KV, 150pF(330Ω) 1sec, 8 points, 25 times/ point Air Discharge: ± 15KV, 150pF(330Ω) 1sec, 8 points, 25 times/ point	Note 1
EMI	30-230 MHz, limit 40 dBu V/m, 230-1000 MHz, limit 47 dBu V/m	

Note1: According to EN61000-4-2, ESD class B: Some performance degradation allowed. No data lost
Self-recoverable. No hardware failures.

Note2:

- Water condensation is not allowed for each test items.
- Each test is done by new TFT-LCD module. Don't use the same TFT-LCD module repeatedly for reliability test.
- The reliability test is performed only to examine the TFT-LCD module capability.
- To inspect TFT-LCD module after reliability test, please store it at room temperature and room humidity for 24 hours at least in advance.

9.2 LCM Outline Dimension (Rear View)

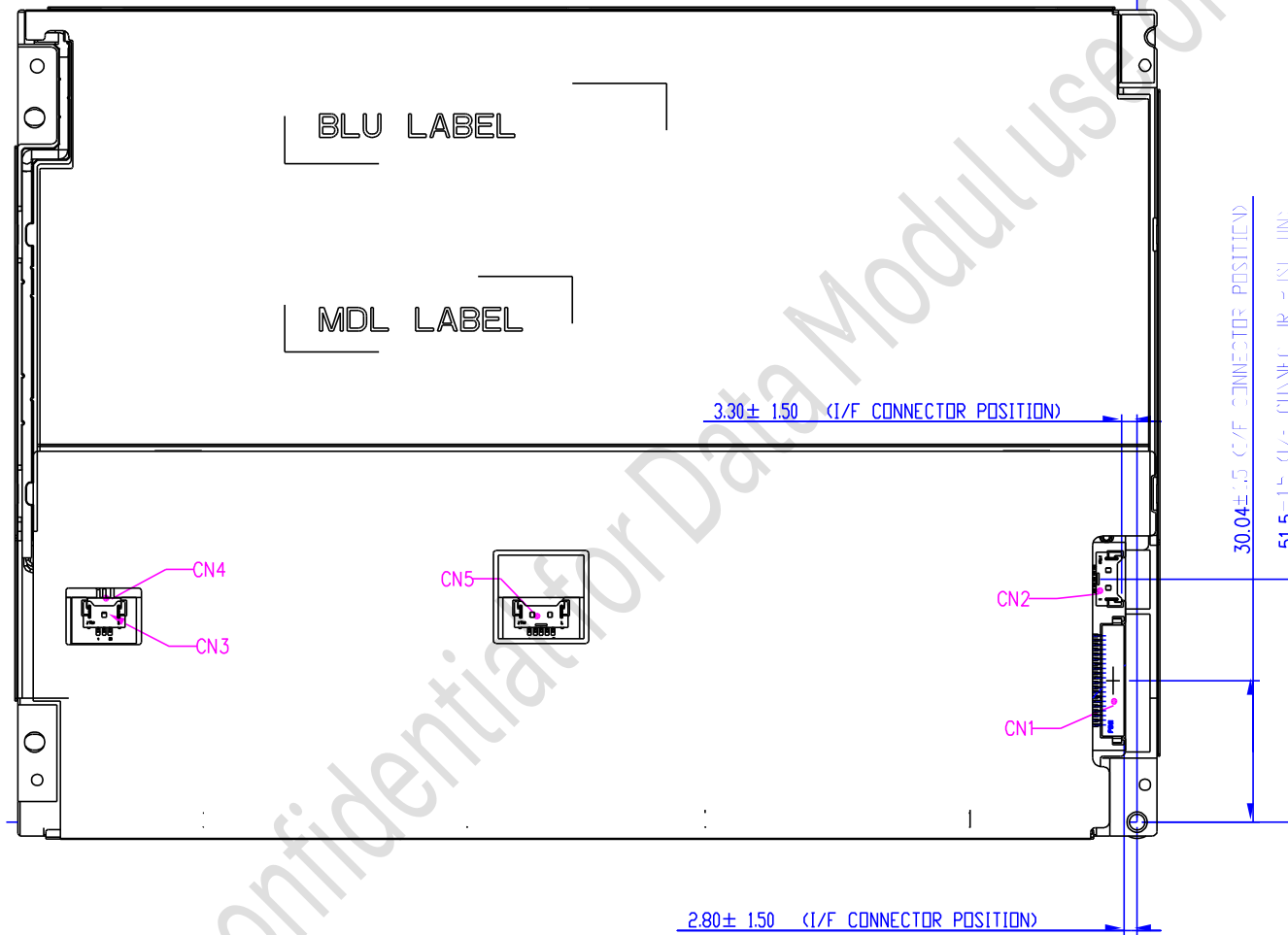

Note: CN 5 is added for ADP internal use.

DATA MODUL

Passion Displayed



All good things come in threes:

With **Hardware**, **Software** and **Services**, we realise unique display solutions that turn your ideas into reality.

www.data-modul.com

