



SPECIFICATION



G156XTN01.0

15.6" - HD - LVDS

Version: 1.1
Date: 28.05.2018

Note: This specification is subject to change without prior notice



Product Specification

G156XTN01.0

AU OPTRONICS CORPORATION

() Preliminary Specification

(V) Final Specification

Module	15.6 Inch Color TFT-LCD
Model Name	G156XTN01.0

Customer	Date
_____	_____
Checked & Approved by	Date
_____	_____
Customer's sign back page	

Approved by	Date
<u>Sean Lin</u>	<u>05/28/2018</u>
Prepared by	Date
<u>Sandy Su</u>	<u>05/28/2018</u>
General Display Business Division / AU Optronics corporation	

Contents

1. Operating Precautions	4
2. General Description	5
2.1 Display Characteristics	5
2.2 Optical Characteristics	6
3. Functional Block Diagram	9
4. Absolute Maximum Ratings.....	10
4.1 Absolute Ratings of TFT LCD Module.....	10
4.2 Absolute Ratings of Environment	10
5. Electrical characteristics	11
5.1 TFT LCD Module.....	11
5.2 Backlight Unit	13
6. Signal Characteristic.....	14
6.1 Pixel Format Image	14
6.2 Signal Description	14
6.3 The Input Data Format	16
6.4 Interface Timing	17
6.5 Power ON/OFF Sequence	18
7. Reliability Test Criteria	19
8. Mechanical Characteristics.....	20
8.1 LCM Outline Dimension (Front View)	20
8.2 LCM Outline Dimension (Rear View).....	21
9. Packaging Spec	22
9.1 Shipping Label (on the rear side of TFT-LCD display).....	22
9.2 Carton & Pallet Package	22
10. Safety.....	23

Record of Revision

Version	Date	Page	Old description	New Description																								
0.1	2017/10/31	All	First Edition for Customer																									
1.0	2018/4/9	5	Physical Size Thickness: 9.1 (D) (Typ.)	Update → 9.07 (Typ.); 9.57 (Max.)																								
		6	2.2 Optical Characteristics Contrast ratio: TBD Response Time: TBD Viewing Angle: TBD Color / Chromaticity Coordinate: TBD Color Gamut: TBD	Update →500(Min.);800(Typ.) →10(Typ.) →85/85/50/80(Typ.);75/75/40/70(Min.) →Value update as below table →62(Typ.) <table border="1" data-bbox="992 737 1346 905"> <tr> <td>Red x_o</td> <td>0.570_o</td> <td>0.620_o</td> <td>0.670_o</td> </tr> <tr> <td>Red y_o</td> <td>0.300_o</td> <td>0.350_o</td> <td>0.400_o</td> </tr> <tr> <td>Green x_o</td> <td>0.274_o</td> <td>0.324_o</td> <td>0.374_o</td> </tr> <tr> <td>Green y_o</td> <td>0.570_o</td> <td>0.620_o</td> <td>0.670_o</td> </tr> <tr> <td>Blue x_o</td> <td>0.103_o</td> <td>0.153_o</td> <td>0.203_o</td> </tr> <tr> <td>Blue y_o</td> <td>0.054_o</td> <td>0.104_o</td> <td>0.154_o</td> </tr> </table>	Red x _o	0.570 _o	0.620 _o	0.670 _o	Red y _o	0.300 _o	0.350 _o	0.400 _o	Green x _o	0.274 _o	0.324 _o	0.374 _o	Green y _o	0.570 _o	0.620 _o	0.670 _o	Blue x _o	0.103 _o	0.153 _o	0.203 _o	Blue y _o	0.054 _o	0.104 _o	0.154 _o
		Red x _o	0.570 _o	0.620 _o	0.670 _o																							
		Red y _o	0.300 _o	0.350 _o	0.400 _o																							
		Green x _o	0.274 _o	0.324 _o	0.374 _o																							
Green y _o	0.570 _o	0.620 _o	0.670 _o																									
Blue x _o	0.103 _o	0.153 _o	0.203 _o																									
Blue y _o	0.054 _o	0.104 _o	0.154 _o																									
9	3.Functional Block Diagram	Update																										
11	5.1.1 Power Specification Conditions	Update → 3.3V																										
13	5.2.1 LED Backlight Unit Pin3 Description	Update → 3.3V																										
1.1	2018/05/28	13	LED Driver Connector Pin1 Symbol: VCC	Update → VLED																								
		15	Pin Assignment Pin 26~30 Symbol: AVDD	Update → VDD																								
		16	6.3 The Input Data Format Remove: SEL68 = "High" for 8 bits LVDS Input	Update → LVDS Input format for 8 bits only																								
		17	6.4.1 Timing Characteristics Vertical Section HorizontalSection	Update →Horizontal →Vertical Section																								

1. Operating Precautions

- 1) Since front polarizer is easily damaged, please be cautious and not to scratch it.
- 2) Be sure to turn off power supply when inserting or disconnecting from input connector.
- 3) Wipe off water drop immediately. Long contact with water may cause discoloration or spots.
- 4) When the panel surface is soiled, wipe it with absorbent cotton or soft cloth.
- 5) Since the panel is made of glass, it may be broken or cracked if dropped or bumped on hard surface.
- 6) To avoid ESD (Electro Static Discharge) damage, be sure to ground yourself before handling TFT-LCD Module.
- 7) Do not open nor modify the module assembly.
- 8) Do not press the reflector sheet at the back of the module to any direction.
- 9) In case if a module has to be put back into the packing container slot after it was taken out from the container, do not press the center of the LED light bar edge. Instead, press at the far ends of the LED light bar edge softly. Otherwise the TFT Module may be damaged.
- 10) At the insertion or removal of the Signal Interface Connector, be sure not to rotate nor tilt the Interface Connector of the TFT Module.
- 11) TFT-LCD Module is not allowed to be twisted & bent even force is added on module in a very short time. Please design your display product well to avoid external force applying to module by end-user directly.
- 12) Small amount of materials having no flammability grade is used in the LCD module. The LCD module should be supplied by power complied with requirements of Limited Power Source (IEC60950 or UL1950), or be applied exemption.
- 13) Severe temperature condition may result in different luminance, response time and lamp ignition voltage.
- 14) Continuous operating TFT-LCD display under low temperature environment may accelerate lamp exhaustion and reduce luminance dramatically.
- 15) The data on this specification sheet is applicable when LCD module is placed in landscape position.
- 16) Continuous displaying fixed pattern may induce image sticking. It's recommended to use screen saver or shuffle content periodically if fixed pattern is displayed on the screen.



2. General Description

This specification applies to the 15.6 inch-wide Color a-Si TFT-LCD Module G156XTN01. The display supports the HD - 1366(H) x 768(V) screen format and 16.7M colors (RGB 6-bits+3-FRC data). All input signals are LVDS interface and this module contains with an LED driver for backlight.

2.1 Display Characteristics

The following items are characteristics summary on the table under 25°C condition:

ITEMS	Unit	SPECIFICATIONS			
Screen Diagonal	[inch]	15.6"			
Active Area	[mm]	344.232 (H) x 193.536 (V)			
Resolution		1366 x 768			
Pixel Pitch	[mm]	0.252 x 0.252			
Pixel Arrangement		R.G.B. Vertical Stripe			
Display Mode		TN Mode, Normally White			
Nominal Input Voltage VDD	[Volt]	+3.3 (typ.)			
LCD Power Consumption	[Watt]	0.66W (Typ.), 0.79W (Max.) (all black pattern)			
LED Power Consumption	[Watt]	4.77W (Typ.), 5.72 W (Max.) (all black pattern)			
Weight	[g]	860 (Typ.)			
Physical Size Include bracket	[mm]		Min.	Typ.	Max.
		Length	363.3	363.8	364.3
		Width	215.4	215.9	216.4
		Thickness		9.07	9.57
Electrical Interface		One channel LVDS			
Surface Treatment		Anti-Glare, 3H			
Support Color		16.7M			
RoHS Compliance		RoHS Compliance			
Temperature Range					
Operating	[°C]	-30 to 85			
Storage (Non-Operating)	[°C]	-30 to 85			
RoHS Compliance		Yes			

2.2 Optical Characteristics

The optical characteristics are measured under stable conditions at 25 °C(Room Temperature):

Item	Unit	Conditions	Min.	Typ.	Max.	Note	
White Luminance (Center)	cd/m ²	I _{LED} =50mA (center point)	320	400		1	
Luminance Uniformity	%	5 points	70	75	-	2,3	
Contrast ratio	--		500	800	-	4	
Response Time	msec	Rising (Tr)+ Falling (Tf)	-	10	-	5	
Viewing Angle	[degree]	Horizontal CR >= 10	(Right)	75	85	-	6
			(Left)	75	85	-	
		Vertical CR >= 10	(Upper)	40	50	-	
			(Lower)	70	80	-	
Color / Chromaticity Coordinate (CIE 1931)	--	Red x	0.570	0.620	0.670		
		Red y	0.300	0.350	0.400		
		Green x	0.274	0.324	0.374		
		Green y	0.570	0.620	0.670		
		Blue x	0.103	0.153	0.203		
		Blue y	0.054	0.104	0.154		
		White x	0.263	0.313	0.363		
		White y	0.279	0.329	0.379		
Color Gamut	%	CIE 1931	-	62	-		

Note 1: Measurement method

Equipment Pattern Generator, Power Supply, Digital Voltmeter, Luminance meter (SR_3 or equivalent)

Aperture 1□with 50cm viewing distance

Test Point Center

Environment < 1 lux

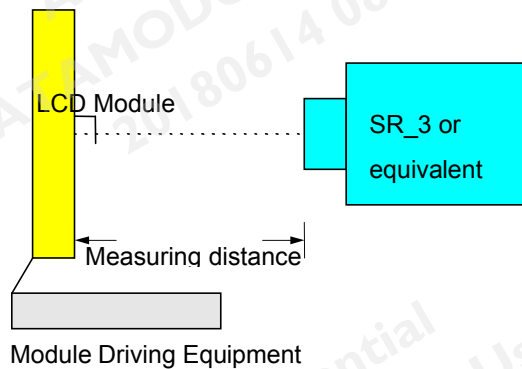

Note 2: Definition of 5 points position

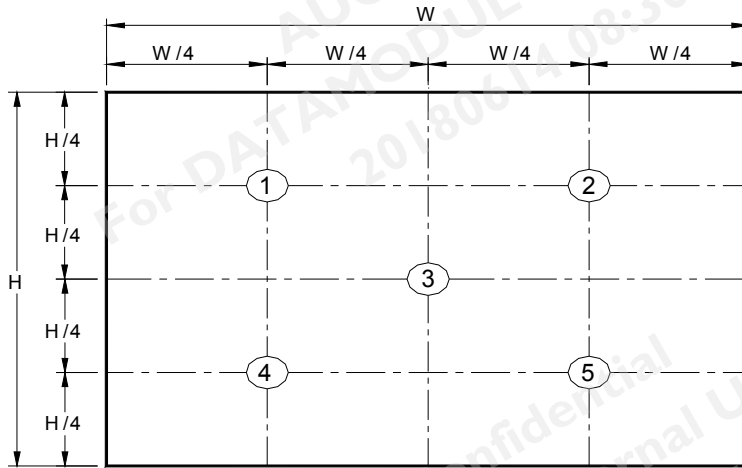

Note 3: The luminance uniformity of 5 points is defined by dividing the minimum luminance values by the maximum test point luminance

$$\delta_{w5} = \frac{\text{Minimum Brightness of five points}}{\text{Maximum Brightness of five points}}$$

Note 4: Definition of contrast ratio (CR):

$$\text{Contrast ratio (CR)} = \frac{\text{Brightness on the "White" state}}{\text{Brightness on the "Black" state}}$$

Note 5: Definition of Response time:

The output signals of photo detector are measured when the input signals are changed from "White" to "Black" (falling time) and from "Black" to "White" (rising time), respectively. The response time interval is between 10% and 90% of amplitudes. Please refer to the figure as below.

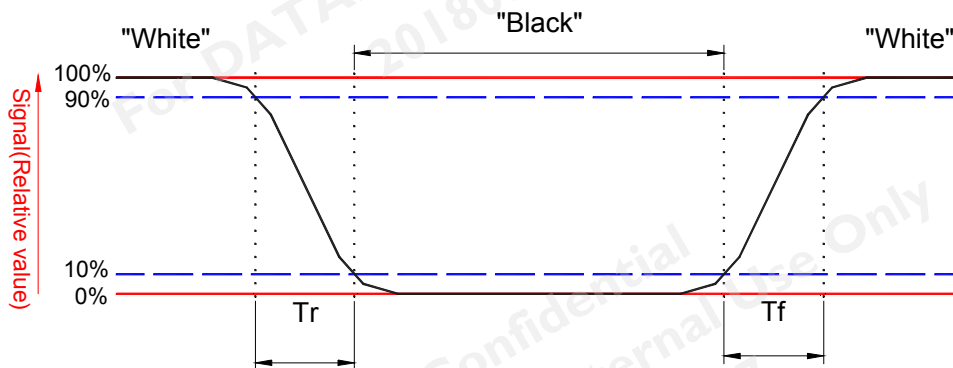

Note 6: Definition of viewing angle

Viewing angle is the measurement of contrast ratio ≥ 10 , at the screen center, over a 180° horizontal and 180° vertical range (off-normal viewing angles). The 180° viewing angle range is broken down as below: 90° (θ) horizontal left and right, and 90° (Φ) vertical high (up) and low (down). The measurement direction is typically perpendicular to the display surface with the screen rotated to its center to develop the desired measurement viewing angle.

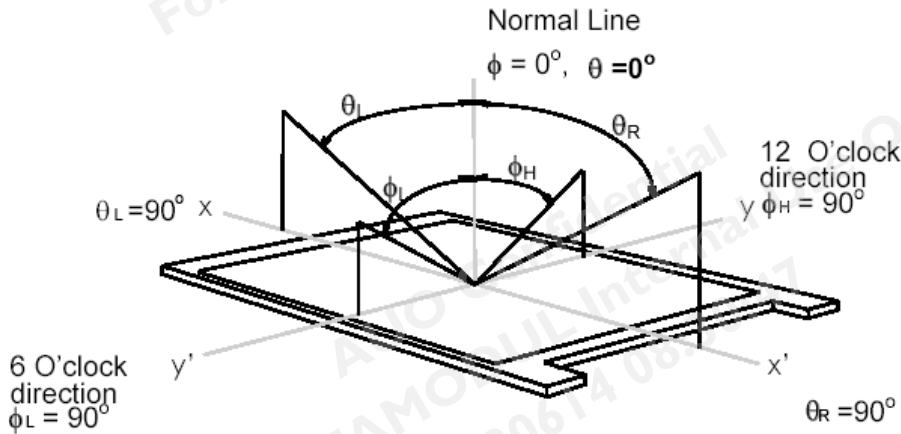

3. Functional Block Diagram

The following diagram shows the functional block of the 15.6 inch Color TFT-LCD Module:

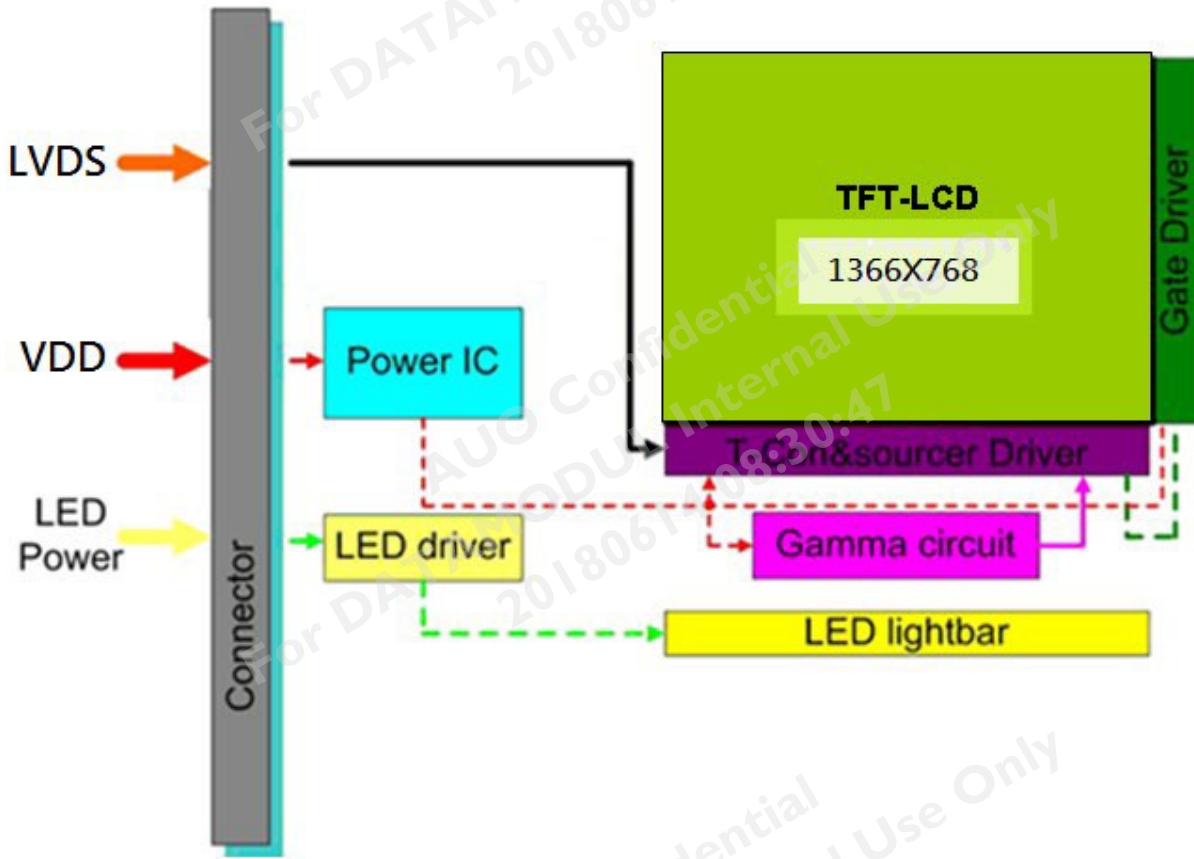

4. Absolute Maximum Ratings

4.1 Absolute Ratings of TFT LCD Module

Item	Symbol	Min	Max	Unit
Logic/LCD Drive Voltage	VDD	0	4.0	[Volt]

4.2 Absolute Ratings of Environment

Item	Symbol	Min.	Max.	Unit
Operating Temperature	TOP	-30	+85	[°C]
Operation Humidity	HOP	5	90	[%RH]
Storage Temperature	TST	-30	+85	[°C]
Storage Humidity	HST	5	90	[%RH]

Note: Maximum Wet-Bulb should be 39 °C and no condensation.

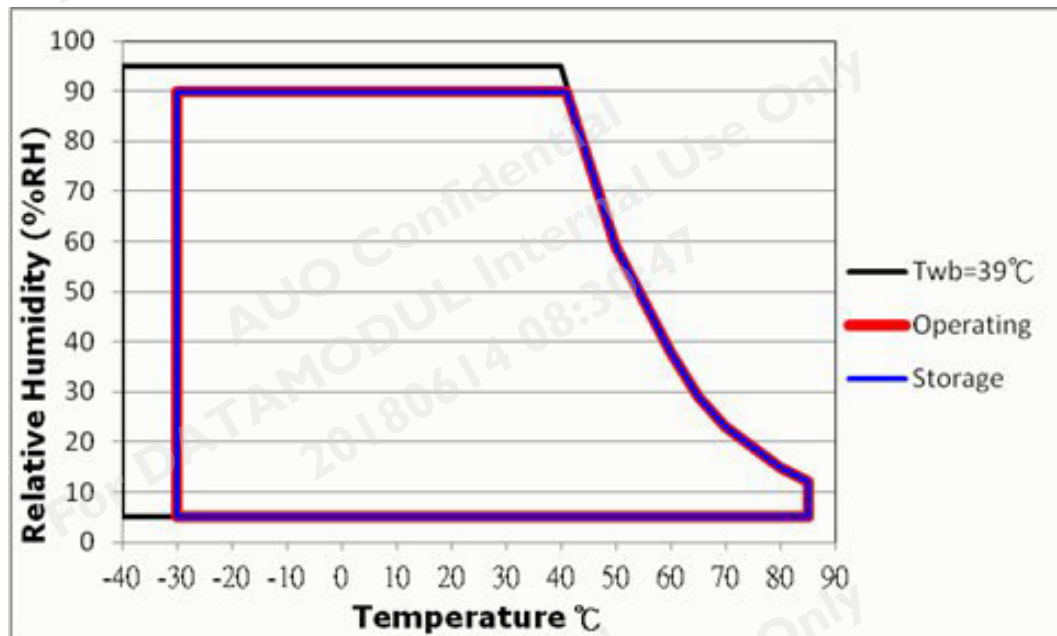

5. Electrical characteristics

5.1 TFT LCD Module

5.1.1 Power Specification

Input power specifications are as following:

Symbol	Parameter	Min	Typ	Max	Unit	Conditions
VDD	Logic/LCD Drive Voltage	3.0	3.3	3.6	[Volt]	+/-10%
IDD	VDD Current ,Input Current	-	0.20	0.24	[A]	VDD= 3.3V, All Black Pattern At 60Hz *Note 1
IRush	LCD Inrush Current	-	-	2.0	[A]	*Note 2
PDD	VDD Power	-	0.66	0.79	[Watt]	VDD= 3.3V, All Black Pattern At 60Hz
VDDrp	Allowable Logic/LCD Drive Ripple Voltage	-	-	100	[mV] p-p	VDD= 3.3V, All Black Pattern At 60Hz

Note 1: Current fuse is built in a module. Current capacity of power supply for VDD should be larger than 2A design value, so that the fuse can be opened at the trouble of electrical circuit of module.

Note 2: Measurement conditions:

The duration of rising time of power input is 470 us.

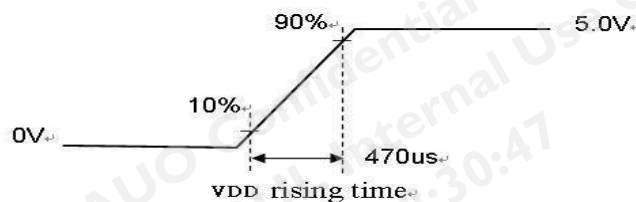
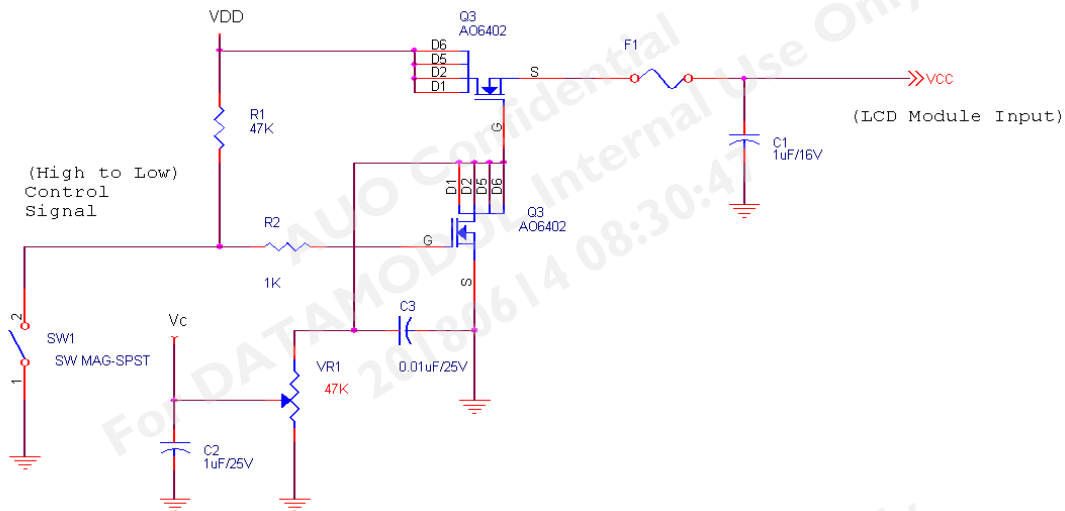

5.1.2 LVDS DC Signal Electrical Characteristics

Symbol	Parameter	Min	Typ	Max	Units	Condition
VTH	Differential Input High Threshold	-	+50	+100	[mV]	VICM = 1.2V
VTL	Differential Input Low Threshold	-100	-50	-	[mV]	VICM = 1.2V
 VID 	Input Differential Voltage	100	-	600	[mV]	
VICM	Differential Input Common Mode Voltage	+1.0	+1.2	+1.5	[V]	VTH-VTL=200MV (Max)

Input signals shall be low or Hi-Z state when VDD is off.

Note : LVDS Signal Waveform

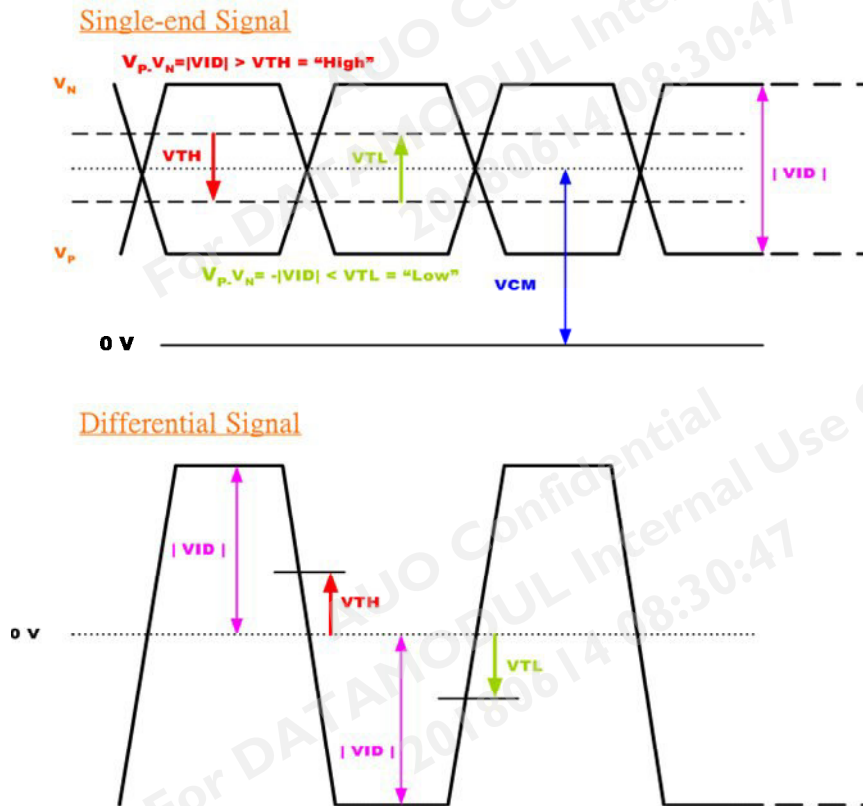

5.2 Backlight Unit

5.2.1 LED Backlight Unit : LED Driver Connector

Connector Name / Designation	LED Connector
Manufacturer	E&T or compatible
Connector Model Number	3808K-F05N-12R or compatible
Mating Connector Model Number	H208K-D05N-22B or compatible

Pin No.	Symbol	Description
Pin1	VLED	12V input
Pin2	GND	GND
Pin3	ON/OFF Enable	3.3V-ON,0V-OFF LED enable
Pin4	Dimming	PWM/Analog
Pin5	NA	NC

5.2.2 Parameter guideline for LED

Following characteristics are measured under a stable condition using an inverter at 25°C (Room Temperature):

LED characteristics

Symbol	Parameter	Min	Typ	Max	Units	Condition
PLED	Backlight Power Consumption	-	4.77	5.72	[Watt]	Ta = 25°C, Note 1 Vin =12V
LTLED	LED Life-Time	50,000	-	-	Hour	Ta = 25°C, Note2

Note 1: Calculator value for reference $P_{LED} = V_F$ (Normal Distribution) * I_F (Normal Distribution) / Efficiency

Note 2: The LED life-time define as the estimated time to 50% degradation of initial luminous at Ta = 25°C.

Backlight input signal characteristics

Symbol	Parameter	Min	Typ	Max	Units	Remark
VLED (Note 1)	LED Power Supply	10.8	12	13.2	[Volt]	Define as Connector Interface (Ta=25°C)
VLED_EN	LED Enable Input High Level	2.5	--	5.5	[Volt]	
	LED Enable Input Low Level	--	--	0.5	[Volt]	
VPWM_EN	PWM Logic Input High Level	2.5	--	5.5	[Volt]	
	PWM Logic Input Low Level	--	--	0.5	[Volt]	
FPWM	PWM Input Frequency *1	200	--	20K	Hz	
Duty	PWM Duty Ratio	5	--	100	%	
Ivcc	Input Current	-	0.4	0.48	A	100% Dimming

Note: Measured on panel VLED

6. Signal Characteristic

6.1 Pixel Format Image

Following figure shows the relationship of the input signals and LCD pixel format.

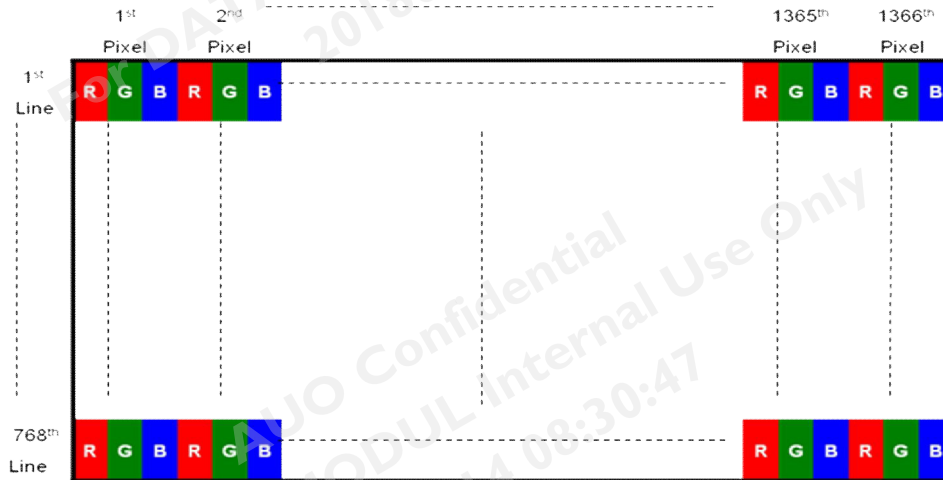

6.2 Signal Description

The module uses a LVDS receiver embedded in AUO's ASIC. LVDS is a differential signal technology for LCD interface and a high-speed data transfer device.

TFT LCD Module: LVDS Connector

Connector Name / Designation	Signal Connector
Manufacturer	JAE / STM
Connector Model Number	FI-XB30SSL-HF15 / MSBKT2407P30HB or compatible
Adaptable Plug	FI-X30HL (Locked Type) or compatible

Pin Assignment

PIN no	Symbol	Function	Remark
1	Reserved	No Connection	
2	Reserved	No Connection	
3	Reserved	No Connection	
4	GND	Ground	
5	RXIN0-	-LVDS Differential Data Input, CH0	
6	RXIN0+	+LVDS Differential Data Input, CH0	
7	GND	Ground	
8	RXIN1-	-LVDS Differential Data Input, CH1	

9	RXIN1+	+LVDS Differential Data Input, CH1	
10	GND	Ground	
11	RXIN2-	-LVDS Differential Data Input, CH2	
12	RXIN2+	+LVDS Differential Data Input, CH2	
13	GND	Ground	
14	RXCLKIN-	-LVDS Differential Clock Input, CH3	
15	RXCLKIN+	+LVDS Differential Clock Input, CH3	
16	GND	Ground	
17	RXIN3-	-LVDS Differential Data Input, CH3	
18	RXIN3+	+LVDS Differential Data Input, CH3	
19	GND	Ground	
20	Reserved	Internal used (recommend no connection)	
21	Reserved	Internal used (recommend no connection)	
22	Reserved	Internal used (recommend no connection)	
23	GND	Ground	
24	GND	Ground	
25	GND	Ground	
26	VDD	Power +3.3V, (typical)	
27	VDD	Power +3.3V, (typical)	
28	VDD	Power +3.3V, (typical)	
29	VDD	Power +3.3V, (typical)	
30	VDD	Power +3.3V, (typical)	

Note 1: Input Signals shall be in low status when VDD is off.

Note 2: High stands for “3.3V”, Low stands for “0V”, NC means “No Connection”.

Note 3: RSV means “Reserved”.

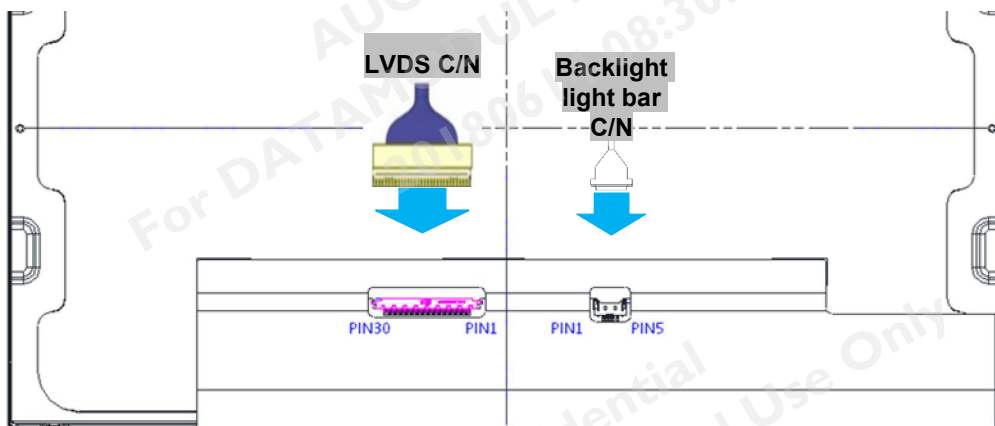

Note3: 30pin start from right side of connector.

Note4: Input signals shall be low or High-impedance state when VDD is off.

6.3 The Input Data Format

LVDS Input format

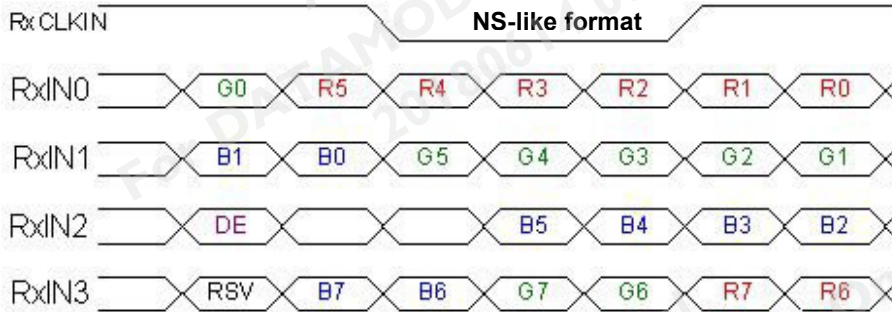

Note1: Please follow PSWG.

Note2: R/G/B data 7:MSB, R/G/B data 0:LSB

Signal Name	Description	Remark
R7 R6 R5 R4 R3 R2 R1 R0	Red Data 7 Red Data 6 Red Data 5 Red Data 4 Red Data 3 Red Data 2 Red Data 1 Red Data 0	Red-pixel Data For 8Bits LVDS input MSB: R7 ; LSB: R0
G7 G6 G5 G4 G3 G2 G1 G0	Green Data 7 Green Data 6 Green Data 5 Green Data 4 Green Data 3 Green Data 2 Green Data 1 Green Data 0	Green-pixel Data For 8Bits LVDS input MSB: G7 ; LSB: G0
B7 B6 B5 B4 B3 B2 B1 B0	Blue Data 7 Blue Data 6 Blue Data 5 Blue Data 4 Blue Data 3 Blue Data 2 Blue Data 1 Blue Data 0	Blue-pixel Data For 8Bits LVDS input MSB: B7 ; LSB: B0
RxCLKIN	LVDS Data Clock	
DE	Data Enable Signal	When the signal is high, the pixel data shall be valid to be displayed.

Note: Output signals from any system shall be low or Hi-Z state when VDD is off.

6.4 Interface Timing

6.4.1 Timing Characteristics

Signal		Symbol	Min	Typ	Max	Unit
Clock Frequency		$1 / T_{\text{Clock}}$	60	76	90	MHz
Horizontal Section	Period	T_V	1446	1566	1936	T_{Line}
	Active	T_{VD}	1366	1366	1366	
	Blanking	T_{VB}	80	200	570	
Vertical Section	Period	T_H	778	806	888	T_{Clock}
	Active	T_{HD}	768	768	768	
	Blanking	T_{HB}	10	38	120	
Frame Rate		F	50	60	75	Hz

- Note:**
1. The maximum Frame Rate < $90\text{MHz} / [(V_Period) * (H_Period)]$
 2. Support DE mode only.
 3. Typical value refer to VESA STANDARD

6.4.2 Input Timing Diagram

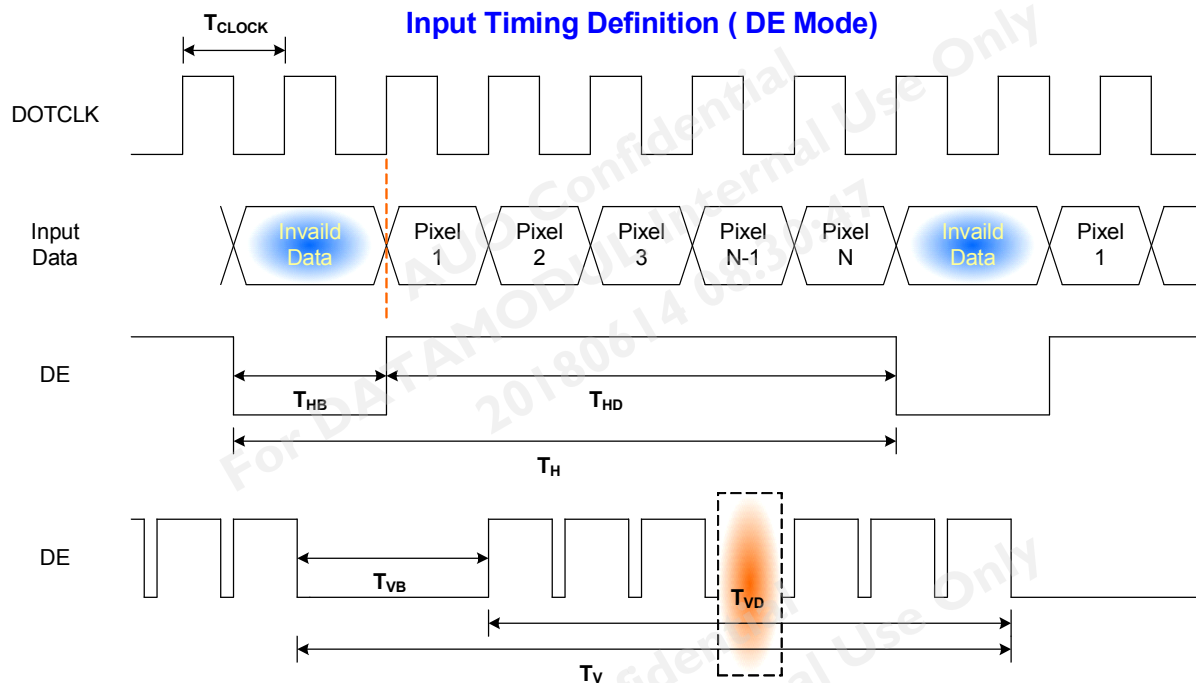

6.5 Power ON/OFF Sequence

VDD power and LED on/off sequence are as follows. Interface signals are also shown in the chart. Signals from any system shall be Hi-Z state or low level when VDD is off.

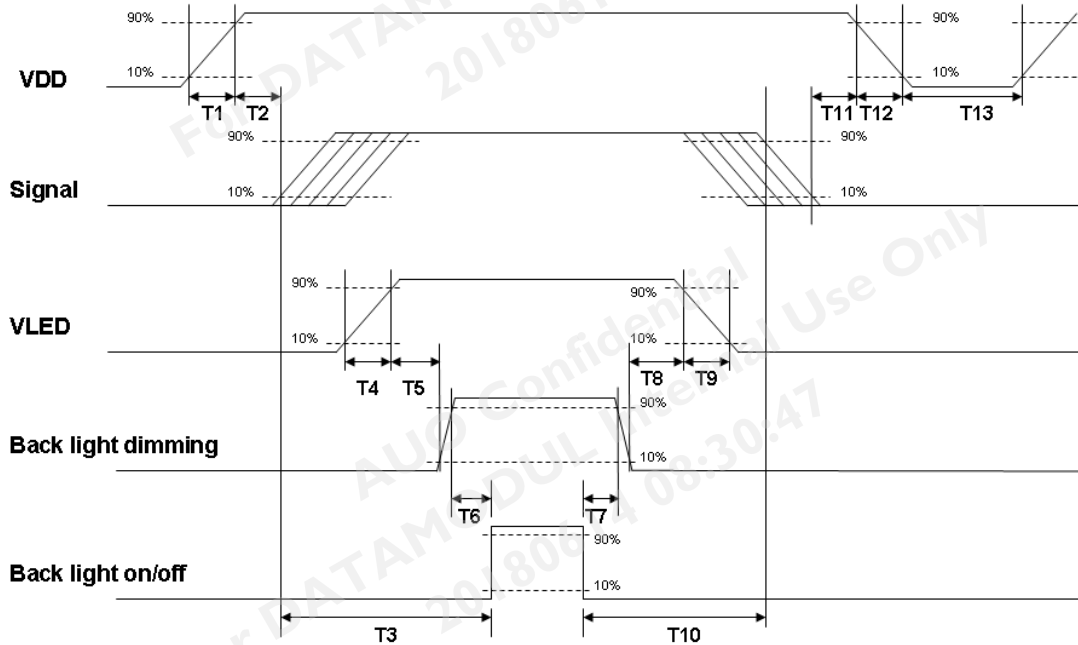

Power ON/OFF sequence timing

Parameter	Value			Units
	Min.	Typ.	Max.	
T1	0.5	-	10	[ms]
T2	0	40	50	[ms]
T3	200	-	-	[ms]
T4	0.5	-	10	[ms]
T5	10	-	-	[ms]
T6	10	-	-	[ms]
T7	0	-	-	[ms]
T8	10	-	-	[ms]
T9	-	-	10	[ms]
T10	110	-	-	[ms]
T11	0.5	16	50	[ms]
T12	-	-	100	[ms]
T13	1000	-	-	[ms]

The above on/off sequence should be applied to avoid abnormal function in the display. Please make sure to turn off the power when you plug the cable into the input connector or pull the cable out of the connector.

7. Reliability Test Criteria

Environment test conditions are listed as following table.

Items	Required Condition	Note
Temperature Humidity Bias (THB)	Ta= 50 °C, 80%RH, 300hours	
High Temperature Operation (HTO)	Ta= 85 °C, 300hours	
Low Temperature Operation (LTO)	Ta= -30 °C, 300hours	
High Temperature Storage (HTS)	Ta= 85 °C, 300hours	
Low Temperature Storage (LTS)	Ta= -30 °C, 300hours	
Thermal Shock Test (TST)	-20 °C /30min, 60 °C /30min, 100 cycles	
Hot Start Test	85 °C /1 Hr min. Power on/off per 5 minutes, 5 times	
Cold Start Test	-30 °C /1 Hr min. Power on/off per 5 minutes, 5 times	
Shock Test (Non-operation)	50G,20ms,Half-sine wave,(+X,+Y,+Z)	
Vibration Test (Non-operation)	1.5G, 10~200~10Hz, Sine wave 30mins/axis, 3 direction (X, Y, Z)	
On/Off Test	On/10sec, Off/10sec, 30,000 cycles	
ESD	Contact : ± 8KV/ operation, Class B Air : ± 15KV / operation, Class B	Note 1
EMI	30-230 MHz, limit 40 dBu V/m, 230-1000 MHz, limit 47 dBu V/m	

Note 1: According to EN61000-4-2 , ESD class B: Some performance degradation allowed. No data lost
Self-recoverable. No hardware failures.

Note 2:

- Water condensation is not allowed for each test items.
- Each test is done by new TFT-LCD module. Don't use the same TFT-LCD module repeatedly for reliability test.
- The reliability test is performed only to examine the TFT-LCD module capability. No function failure occurs. Mura shall be ignored after high temperature reliability test.
- To inspect TFT-LCD module after reliability test, please store it at room temperature and room humidity for 24 hours at least in advance.

8. Mechanical Characteristics

8.1 LCM Outline Dimension (Front View)

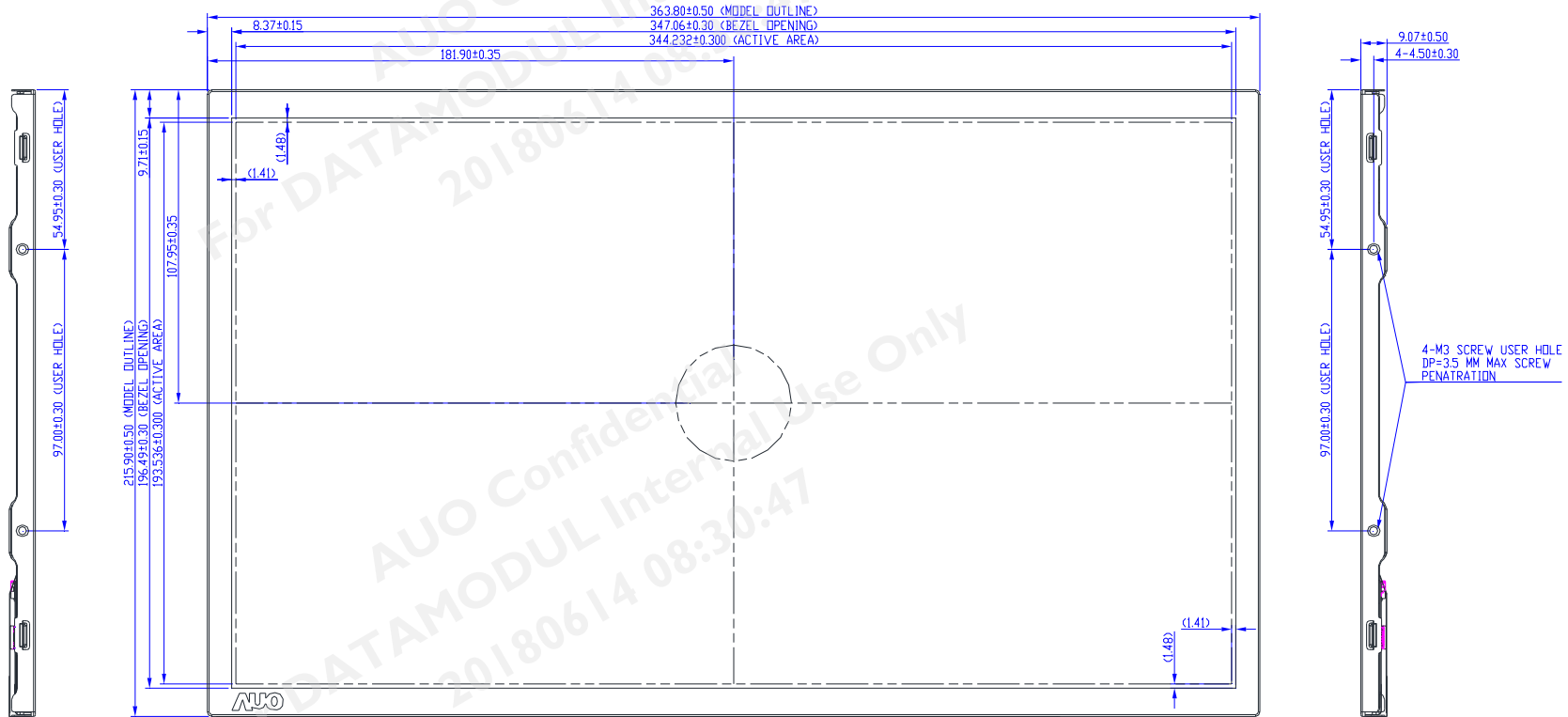

NOTE:

1. PRELIMINARY DRAWING FOR REFERENCE ONLY.
2. TOLERANCE WITHOUT SPECIFIED TO BE 0.5MM.
3. I/F CONNECTOR: STM MSBK12407P30HB.
4. THIS DIMENSION EXCLUDES DEFORMATION.
5. TORQUE OF M3 USER HOLE SHOULD BE WITHIN 4KGF-CM AND RE-SCREW 10 TIME

8.2 LCM Outline Dimension (Rear View)

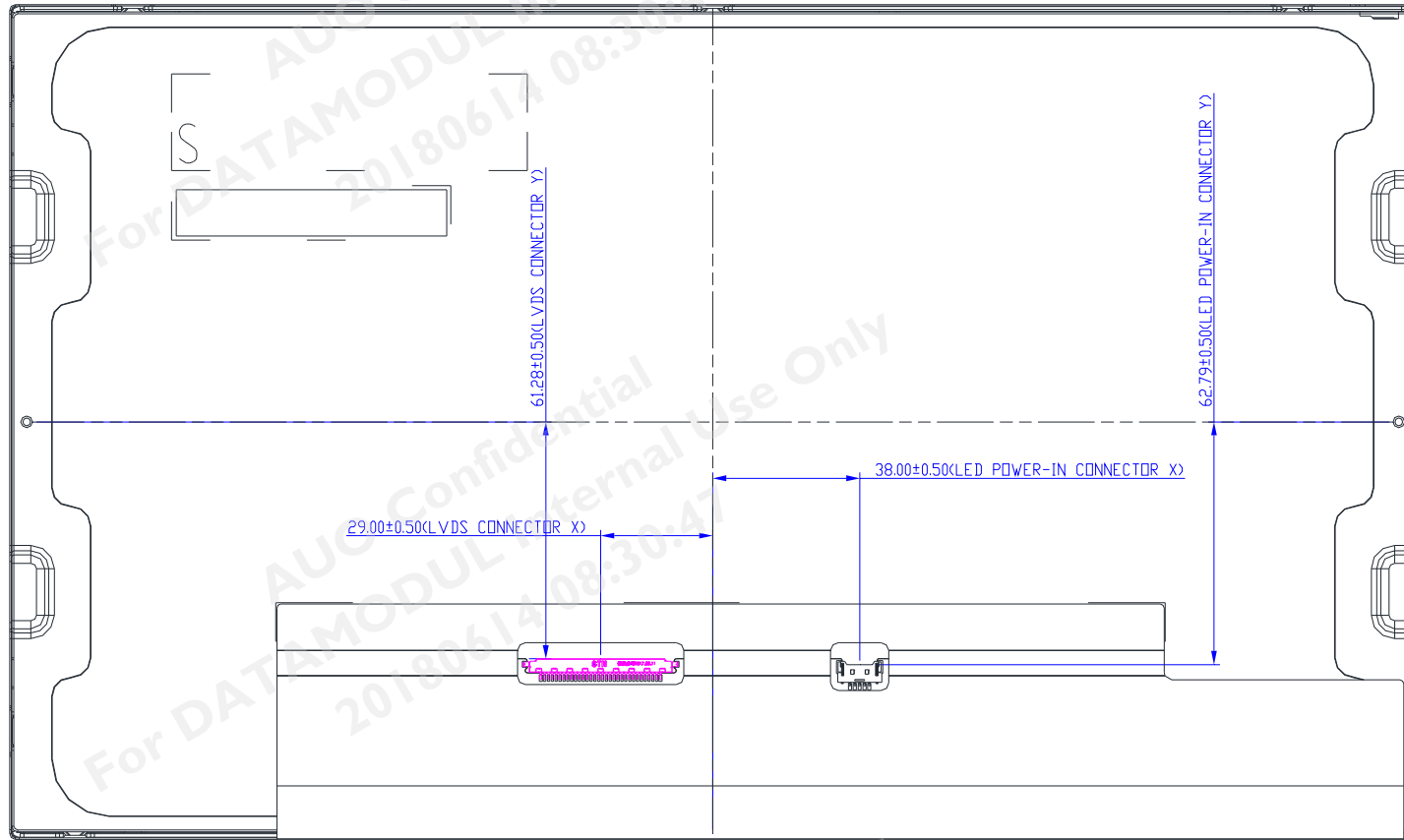

9. Packaging Spec

9.1 Shipping Label (on the rear side of TFT-LCD display)

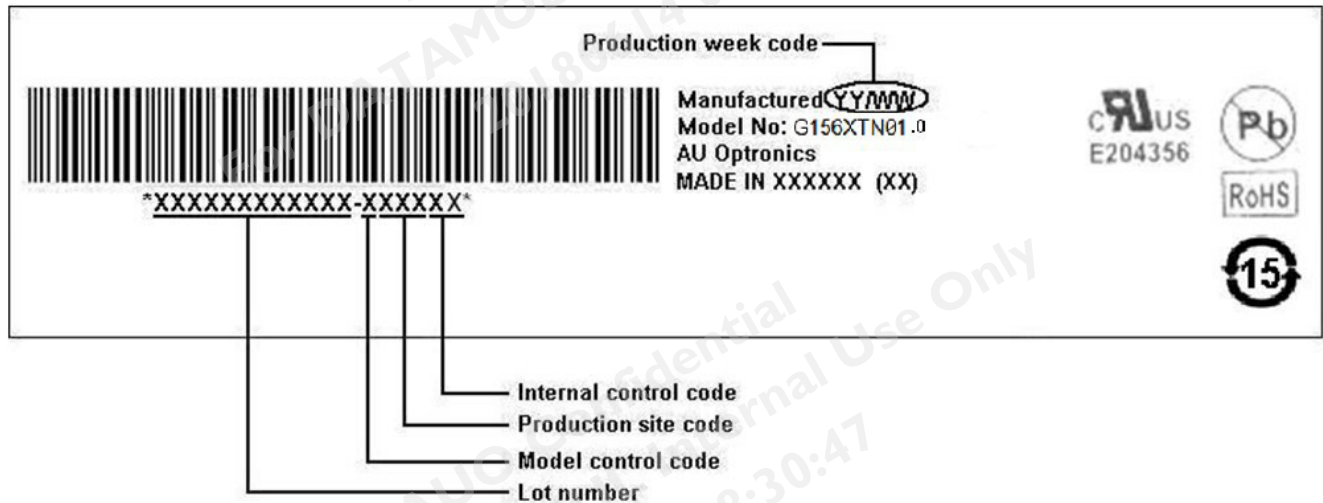

9.2 Carton & Pallet Package

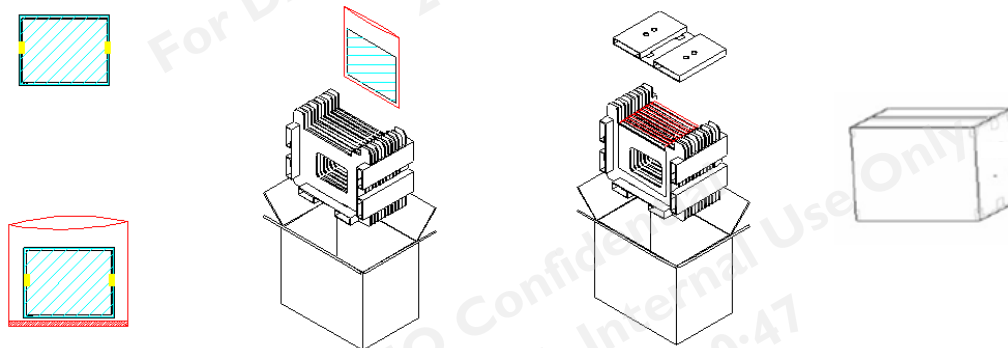

Max capacity : 16 TFT-LCD module per carton

Max weight: 15.3 kg per carton

Outside dimension of carton: 450mm(L)*375mm(W)*319mm(H)

Pallet size : 1150 mm* 910 mm*132mm

Box stacked

Module by air : (2 *3) *4 layers · one pallet put 24 boxes, total 384pcs module

Module by sea : (2 *3) *4 layers+(2 *3) *1 layers, two pallet put 30 boxes, total 480pcs module

Module by sea_HQ : (2 *3) *4 layers+(2 *3) *2 layers, two pallet put 42 boxes, total 576 pcs module

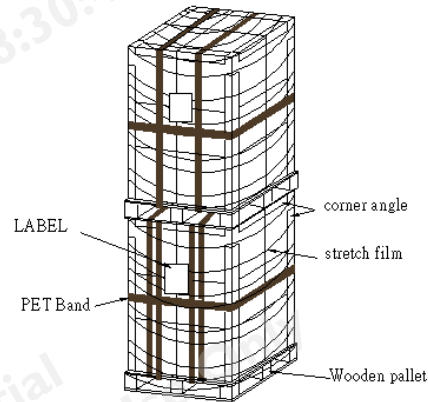
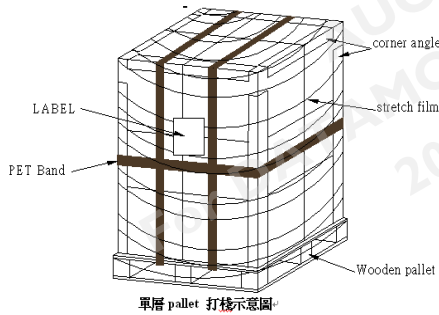

10. Safety

10.1 Sharp Edge Requirements

There will be no sharp edges or corners on the display assembly that could cause injury.

10.2 Materials

10.2.1 Toxicity

There will be no carcinogenic materials used anywhere in the display module. If toxic materials are used, they will be reviewed and approved by the responsible AUO toxicologist.

10.2.2 Flammability

All components including electrical components that do not meet the flammability grade UL94-V1 in the module will complete the flammability rating exception approval process.

The printed circuit board will be made from material rated 94-V1 or better. The actual UL flammability rating will be printed on the printed circuit board.

10.3 Capacitors

If any polarized capacitors are used in the display assembly, provisions will be made to keep them from being inserted backwards.

10.4 National Test Lab Requirement

The display module will satisfy all requirements for compliance to:

UL 60950-1 second edition

U.S.A. Information Technology Equipment



ALL TECHNOLOGIES. ALL COMPETENCIES. ONE SPECIALIST.

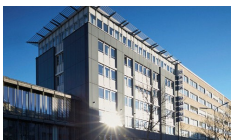

DATA MODUL AG
Landsberger Straße 322
DE-80687 Munich
Phone: +49-89-56017-0

DATA MODUL WEIKERSHEIM GMBH
Lindenstraße 8
DE-97990 Weikersheim
Phone: +49-7934-101-0



More information and worldwide locations can be found at

www.data-modul.com