



SPECIFICATION

INNOLUX

G200HJJ-L01

19.53" – FHD – LVDS

Version: 3.1

Date: 15.04.2021

Note: This specification is subject to change without prior notice

Doc. Number :

- Tentative Specification
- Preliminary Specification
- Approval Specification

MODEL NO.: G200HJJ
SUFFIX: L01

Customer:	
APPROVED BY	SIGNATURE
Name / Title _____	_____
Note	
Product Version C1/G2	

Please return 1 copy for your confirmation with your signature and comments.	

Approved By	Checked By	Prepared By
陳立錚	林秋森	許秣茵

CONTENTS

1. GENERAL DESCRIPTION	5
1.1 OVERVIEW	5
1.2 GENERAL SPECIFICATIONS	5
2. MECHANICAL SPECIFICATIONS	5
3. ABSOLUTE MAXIMUM RATINGS	6
3.1 ABSOLUTE RATINGS OF ENVIRONMENT	6
3.2 ELECTRICAL ABSOLUTE RATINGS	7
3.2.1 TFT-LCD MODULE	7
3.2.2 BACKLIGHT UNIT.....	7
4. ELECTRICAL SPECIFICATIONS	8
4.1 FUNCTION BLOCK DIAGRAM	8
4.2.INTERFACE CONNECTIONS	9
4.3 ELECTRICAL CHARACTERISTICS	11
4.3.1 LCD ELETRONICS SPECIFICATION	11
4.3.2 VCC POWER DIP CONDITION	13
4.3.3 BACKLIGHT UNIT.....	13
4.3.4 CONVERTER ELECTRICAL CHARATERISTICS	14
4.3.5 CONVERTER INPUT CONNECTOR PIN ASSIGNMENT	15
4.4LVDS INPUT SIGNAL SPECIFICATIONS	15
4.4.1 LVDS DATA MAPPING TABLE	15
4.4.2 COLOR DATA INPUT ASSIGNMENT	16
4.5 DISPLAY TIMING SPECIFICATIONS	17
4.6 POWER ON/OFF SEQUENCE.....	19
5. OPTICAL CHARACTERISTICS	20
5.1 TEST CONDITIONS	20
5.2 OPTICAL SPECIFICATIONS	20
6. RELIABILITY TEST ITEM	24
7.PACKING	25
7.1 PACKING SPECIFICATIONS	25
7.2 PACKING METHOD	25
7.3 PALLET.....	26
7.4 UN-PACKING METHOD	27
8. INX MODULE LABEL.....	28
9. PRECAUTIONS	29
9.1 ASSEMBLY AND HANDLING PRECAUTIONS	29

9.2 SAFETY PRECAUTIONS	29
Appendix 2. OUTLINE DRAWING	30

REVISION HISTORY

Version	Date	Page	Description
3.0	Aug.27, 2020	All	Spec Ver.3.0 was first issued.
3.1	Apr.15,2021	P1	Add Note product version C1/C2

1. GENERAL DESCRIPTION

1.1 OVERVIEW

G200HJJ-L01 is a 19.53" TFT Liquid Crystal Display IAV module white-LED back-light unit and 30 pins 2 channels LVDS interface. This module supports 1920x1080 native resolutions and can display up to 16.7 millions colors. The converter module for LED backlight is built-in.

1.2 GENERAL SPECIFICATIONS

Item	Specification	Unit	Note
Screen Size	19.53" real diagonal		
Driver Element	a-si TFT active matrix	-	-
Pixel Number	1920 x R.G.B. x 1080	pixel	-
Pixel Pitch	0.2265 (H) x 0.221 (V)	mm	-
Pixel Arrangement	RGB vertical stripe	-	-
Display Colors	16.7M	color	-
Transmissive Mode	Normally black	-	-
Surface Treatment	AG type, 3H hard coating, Haze 25	-	-
Display Orientation	Signal input with "INX"		(2)
Power Consumption	Total 30.0W (Max.) @ cell 5.5 W (Max.), BL 24.5W(Max.)		(1)

Note (1) The specified power consumption: Total= cell(reference 4.3.1)+BL(reference 4.3.4)

Note (2)

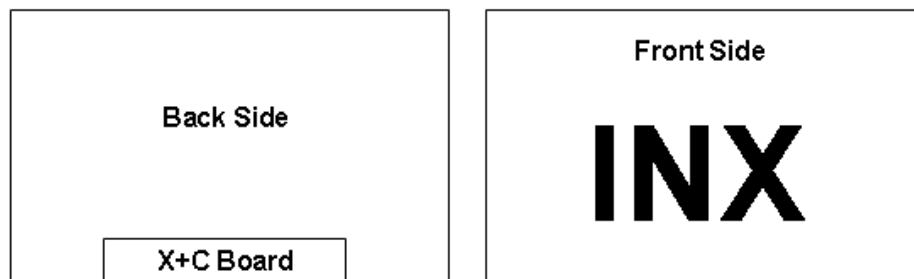

2. MECHANICAL SPECIFICATIONS

Item		Min.	Typ.	Max.	Unit	Note
Module Size	Horizontal (H)	458.5	459	459.5	mm	(1)
	Vertical (V)	262.5	263.0	263.5	mm	
	Thickness (T)	11.47	11.97	12.47	mm	
Bezel Area	Horizontal	437.68	438.18	438.68	mm	
	Vertical	241.48	241.98	242.48	mm	
Active Area	Horizontal	-	434.88	-	mm	
	Vertical	-	238.68	-	mm	
Weight		1580	1655	1730	g	

Note (1) Please refer to the attached drawings for more information of front and back outline dimensions.

3. ABSOLUTE MAXIMUM RATINGS

3.1 ABSOLUTE RATINGS OF ENVIRONMENT

Item	Symbol	Value		Unit	Note
		Min.	Max.		
Storage Temperature	TST	-20	60	°C	(1)
Operating Ambient Temperature	TOP	0	50	°C	(1), (2)

Note (1)

- (a) 90 %RH Max. ($T_a \leq 40\text{ }^\circ\text{C}$).
- (b) Wet-bulb temperature should be 39 °C Max ($T_a \leq 40\text{ }^\circ\text{C}$).
- (c) No condensation.

Note (2) Panel surface temperature should be (65 °C) max.

Panel surface temperature should be 0 °C min. and (65 °C)max under $V_{cc}=5.0V$, $f_r=60\text{Hz}$, typical LED string current, 25 °C ambient temperature, and no humidity control . Any condition of ambient operating temperature ,the surface of active area should be keeping not higher than (65 °C).

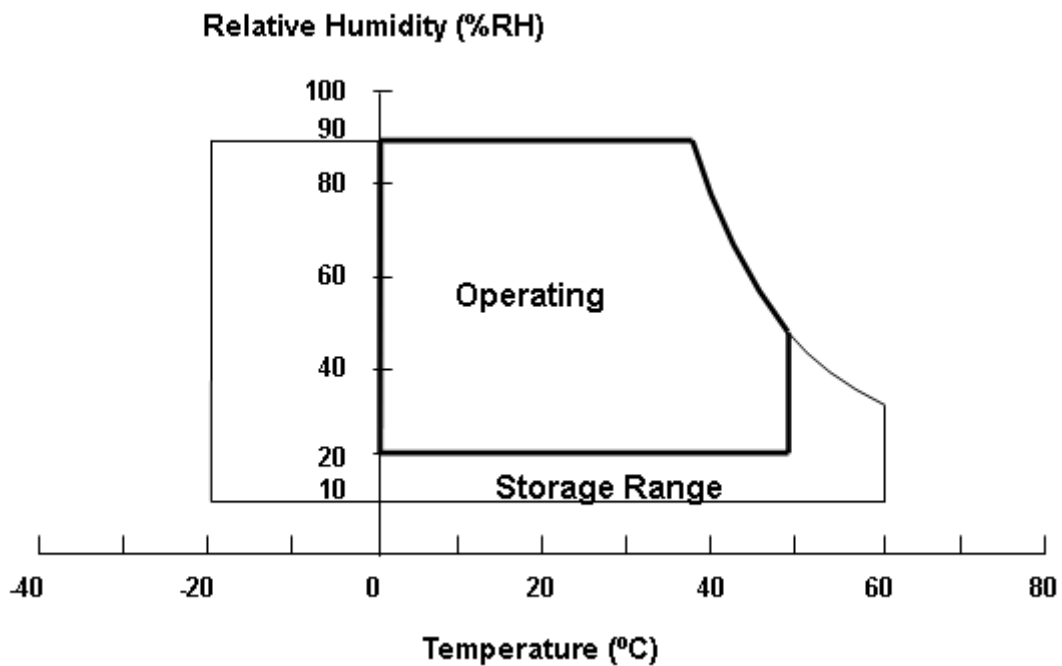

3.2 ELECTRICAL ABSOLUTE RATINGS

3.2.1 TFT-LCD MODULE

Item	Symbol	Value		Unit	Note
		Min.	Max.		
Power Supply Voltage	VCCS	-0.3	6.0	V	(1)
Logic Input Voltage	V _{IN}	-0.3	3.6	V	

3.2.2 BACKLIGHT UNIT

Item	Symbol	Value		Unit	Note
		Min.	Max.		
Converter Input Voltage	V _i	-0.3	22.0	V	(1), (2)
Backlight Enable Voltage	EN	-0.3	5.5	V	
Backlight Adjust	E_PWM	-0.3	5.5	V	

Note (1) Permanent damage to the device may occur if maximum values are exceeded. Function operation should be restricted to the conditions described under Normal Operating Conditions.

Note (2) Specified values are for input pin of LED light bar at Ta=25±2 °C (Refer to 4.3.3 and 4.3.4 for further information).

4. ELECTRICAL SPECIFICATIONS

4.1 FUNCTION BLOCK DIAGRAM

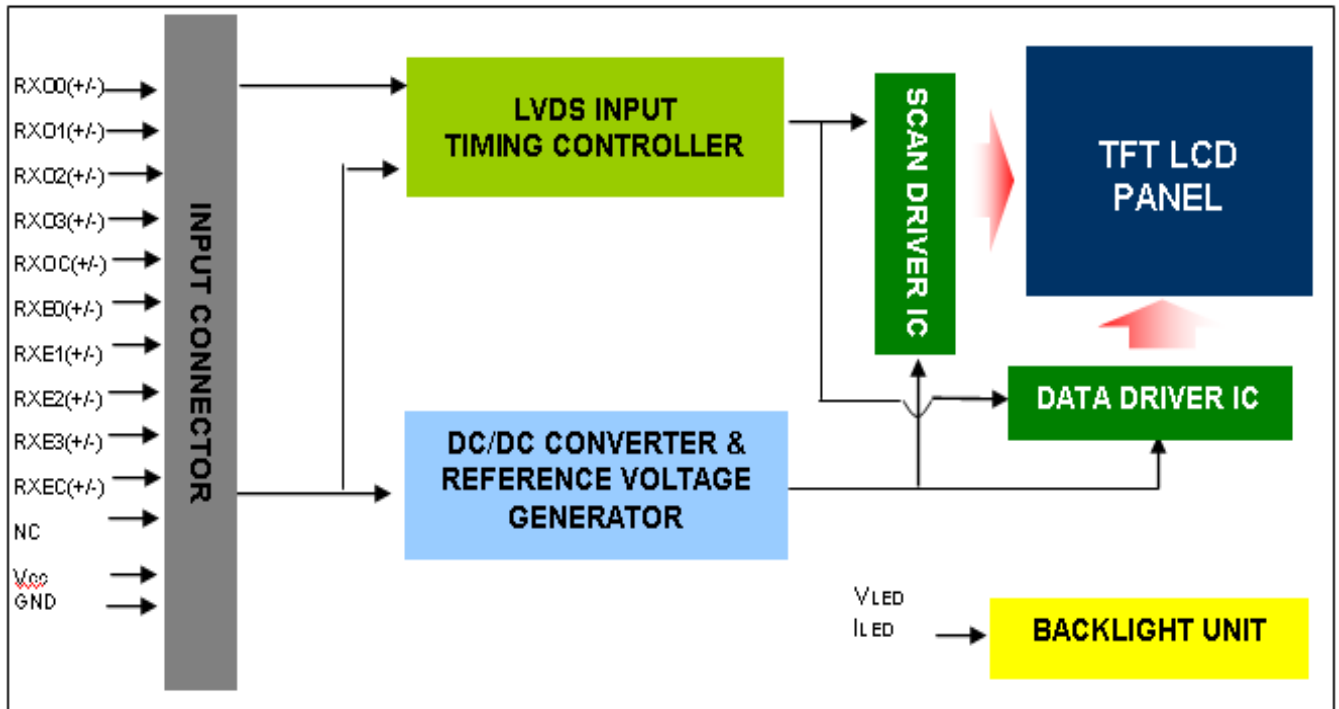

Fig. 4-1 Module Function Block Diagram

4.2.INTERFACE CONNECTIONS

PIN ASSIGNMENT

Pin	Name	Description
1	RXO0-	Negative LVDS differential data input. Channel O0 (odd)
2	RXO0+	Positive LVDS differential data input. Channel O0 (odd)
3	RXO1-	Negative LVDS differential data input. Channel O1 (odd)
4	RXO1+	Positive LVDS differential data input. Channel O1 (odd)
5	RXO2-	Negative LVDS differential data input. Channel O2 (odd)
6	RXO2+	Positive LVDS differential data input. Channel O2 (odd)
7	GND	Ground
8	RXOC-	Negative LVDS differential clock input. (odd)
9	RXOC+	Positive LVDS differential clock input. (odd)
10	RXO3-	Negative LVDS differential data input. Channel O3(odd)
11	RXO3+	Positive LVDS differential data input. Channel O3 (odd)
12	RXE0-	Negative LVDS differential data input. Channel E0 (even)
13	RXE0+	Positive LVDS differential data input. Channel E0 (even)
14	GND	Ground
15	RXE1-	Negative LVDS differential data input. Channel E1 (even)
16	RXE1+	Positive LVDS differential data input. Channel E1 (even)
17	GND	Ground
18	RXE2-	Negative LVDS differential data input. Channel E2 (even)
19	RXE2+	Positive LVDS differential data input. Channel E2 (even)
20	RXEC-	Negative LVDS differential clock input. (even)
21	RXEC+	Positive LVDS differential clock input. (even)
22	RXE3-	Negative LVDS differential data input. Channel E3 (even)
23	RXE3+	Positive LVDS differential data input. Channel E3 (even)
24	GND	Ground
25	NC	For LCD internal use only, Do not connect
26	NC	For LCD internal use only, Do not connect
27	NC	For LCD internal use only, Do not connect
28	Vcc	+5.0V power supply
29	Vcc	+5.0V power supply
30	Vcc	+5.0V power supply

Note (1) Connector Part No.:

187098-30091 (P-TWO) or WF13-422-3033 (FCN) or equivalent

Note (2) User's connector Part No:

Mating Wire Cable Connector Part No.: FI-X30H(JAE) or FI-X30HL(JAE)

Mating FFC Cable Connector Part No.: 217007-013001 (P-TWO) or JF05X030-1 (JAE).

Note (3) The first pixel is odd.

Note (4) Input signal of even and odd clock should be the same timing.

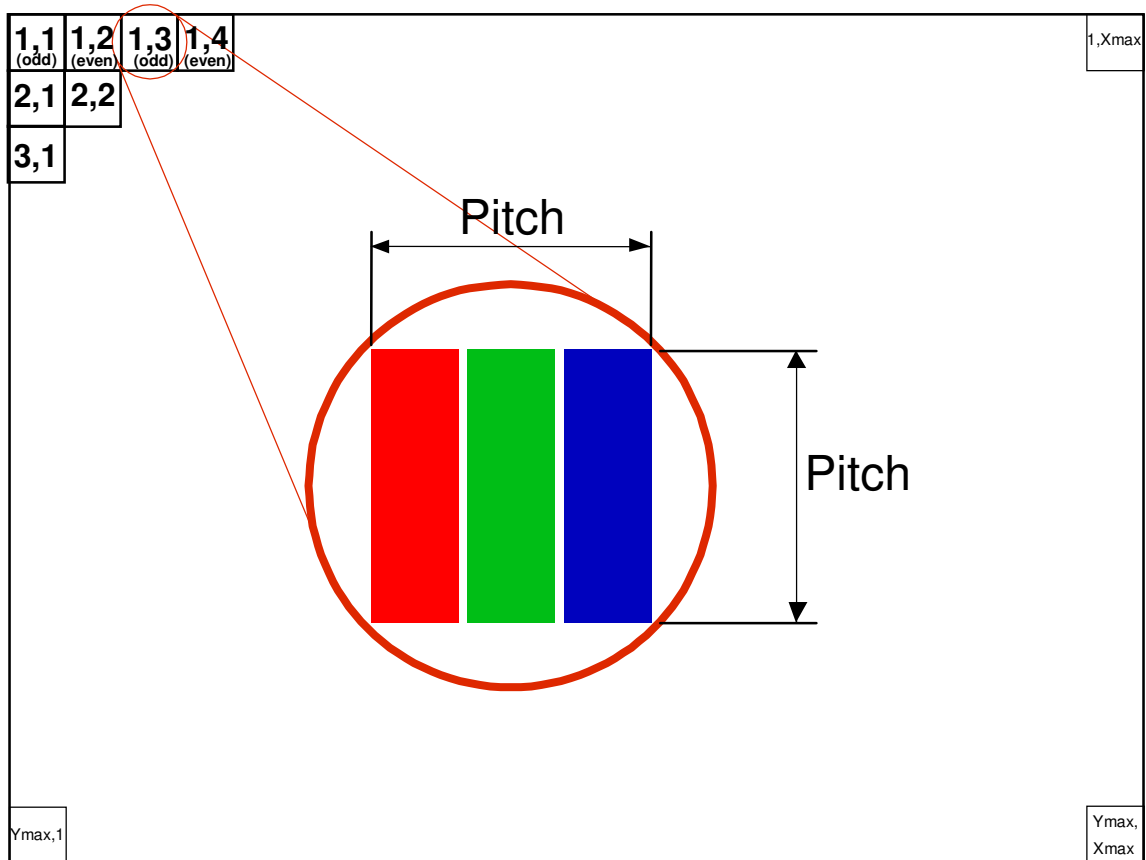

4.3 ELECTRICAL CHARACTERISTICS

4.3.1 LCD ELETRONICS SPECIFICATION

Parameter	Symbol	Value			Unit	Note
		Min.	Typ.	Max.		
Power Supply Voltage	V _{CC}	4.5	5	5.5	V	-
Ripple Voltage	V _{RP}	-	-	300	mV	-
Rush Current	I _{RUSH}	-	-	3	A	(2)
Power Supply Current	White		0.7	0.83	A	(3)a
	Black		0.67	0.79	A	(3)b
	Vertical Stripe		0.92	1.1	A	(3)c
Power Consumption	PLCD		4.6	5.5	Watt	(4)
LVDS differential input voltage	V _{id}	100	-	600	mV	
LVDS common input voltage	V _{ic}	1.0	1.2	1.4	V	
Logic High Input Voltage	V _{IH}	-	-	0.1	V	
Logic Low Input Voltage	V _{IL}	-0.1	-		V	

Note (1) The ambient temperature is Ta = 25 ± 2 °C.

Note (2) Measurement Conditions:

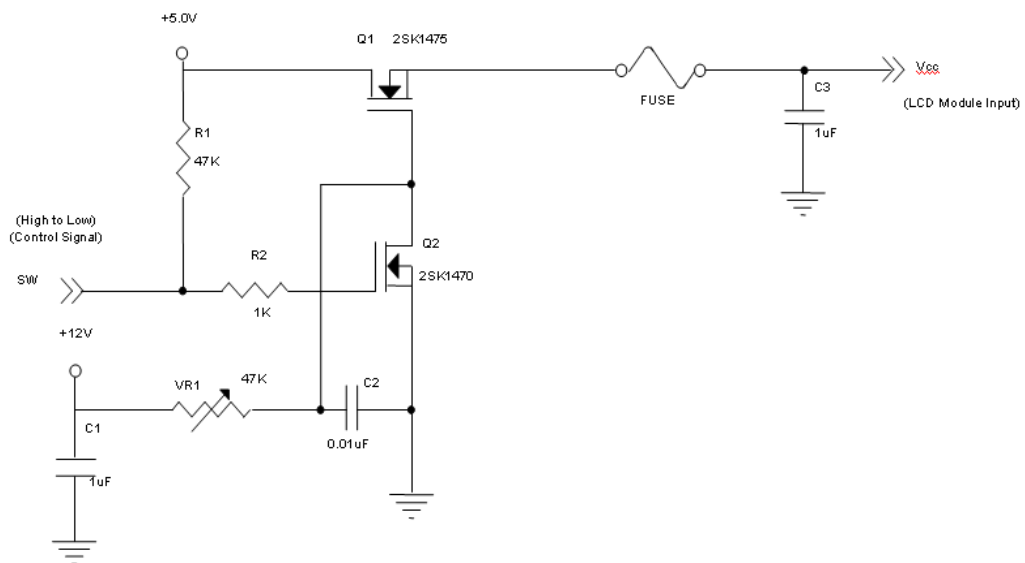

Vcc rising time is 470µs

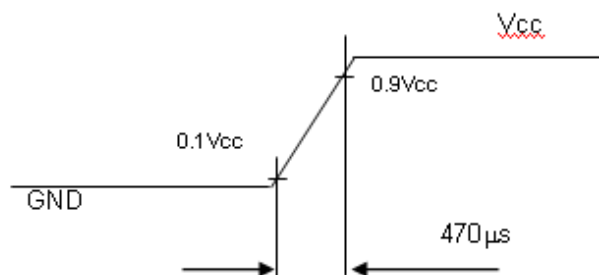

Note (3) The specified power supply current is under the conditions at $V_{cc} = 5.0\text{ V}$, $T_a = 25 \pm 2\text{ }^\circ\text{C}$, $F_r = 60\text{ Hz}$, whereas a power dissipation check pattern below is displayed.

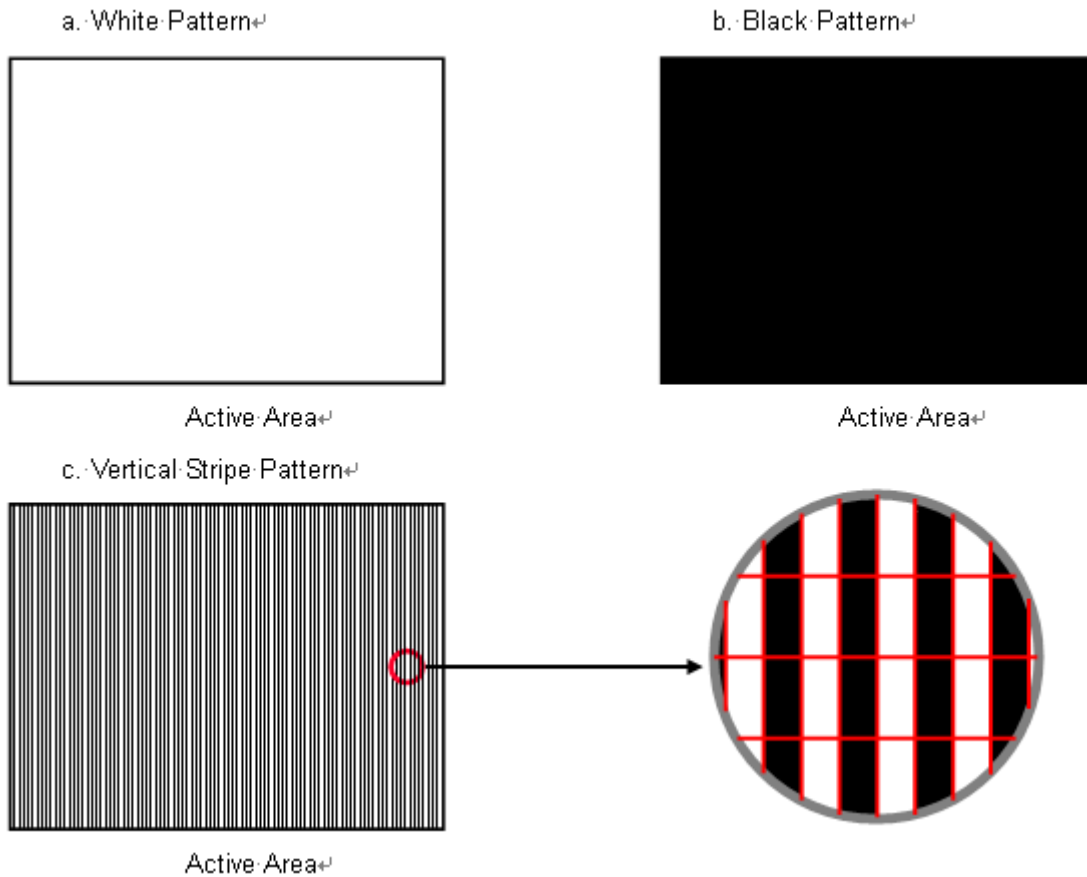

Note (4) The power consumption is specified at the pattern with the maximum current.

Note (5) The LVDS input characteristics are as follows:

Single-end Signals

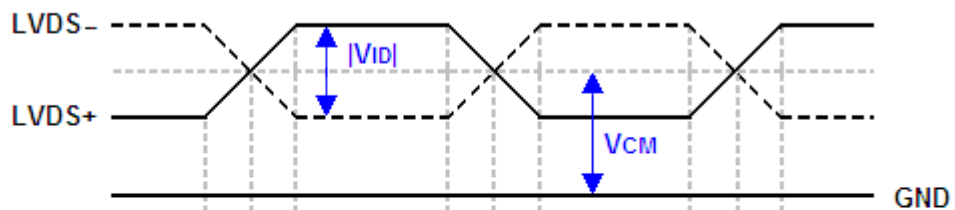

Differential Signal

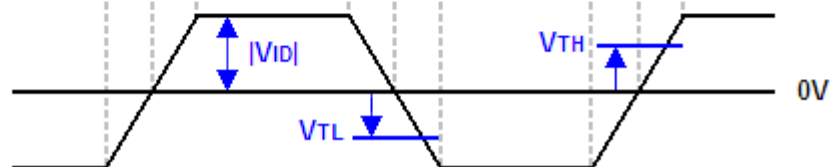

4.3.2 VCC POWER DIP CONDITION

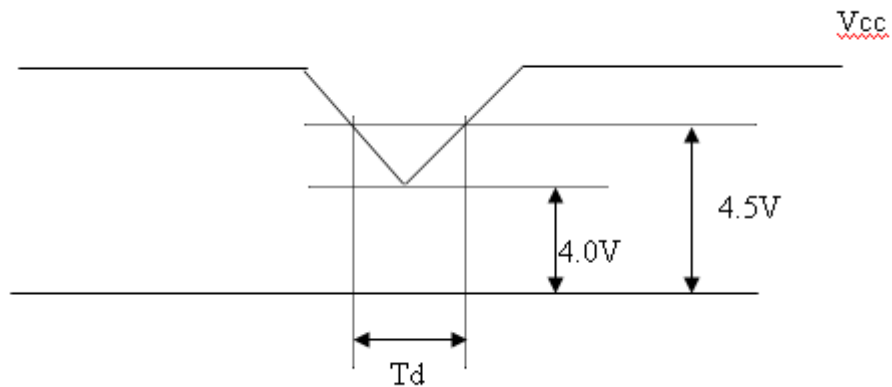

Dip condition: $4.0 \leq V_{cc} \leq 4.5$, $T_d \leq 20\text{ms}$

4.3.3 BACKLIGHT UNIT

Parameter	Symbol	Value			Unit	Note
		Min.	Typ.	Max.		
LED Light Bar Input Voltage Per Input Pin	VPIN	---	37.2	39.6	V	(1), Duty=100%, IPIN=(90)mA
LED Light Bar Current Per Input Pin	IPIN	---	90	95	mA	(1), (2) Duty=100%
LED Life Time	LLED	50000			Hrs	(3)
Power Consumption	PBL	---	20.08	21.38	W	(1) Duty=100%, IPIN=(90)mA

Note (1) LED light bar input voltage and current are measured by utilizing a true RMS multimeter as shown below:

Note (2) $PBL = IPIN \times VPIN \times \text{input pins}$

Note (3) The lifetime of LED is defined as the time when LED packages continue to operate under the conditions at $T_a = 25 \pm 2 \text{ }^\circ\text{C}$ and $I = (90)\text{mA}$ (per chip) until the brightness becomes $\leq 50\%$ of its original value.

Note (4) The module must be operated with constant driving current.

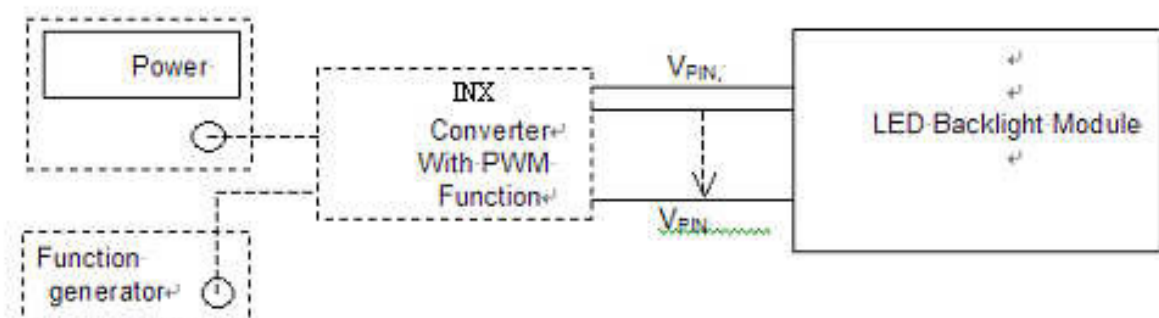

4.3.4 CONVERTER ELECTRICAL CHARACTERISTICS

Ta = 25 ± 2 °C

Parameter	Symbol	Value			Unit	Note	
		Min.	Typ.	Max.			
Converter Power Supply Voltage	Vi	19.0	19.5	20.0	V	(Duty 100%)	
Converter Input Ripple voltage	ViRP	-	-	500	mV	(Duty 100%)	
Converter Power Supply Current	Ii	---	1.14	1.26	A	@ Vi = 19.5V (Duty 100%)	
Converter Inrush Current	IiRUSH	-	-	3.0	A	@ Vi rising time=10ms (Vi=+19.5V)	
Input Power Consumption	Pi	---	22.3	24.5	W	@ Vi = 19.5V (Duty 100%)	
BL Control Level	Backlight on	BLON	2.5	3.3	5.0	V	
	Backlight off		0	0	0.2	V	
PWM Control Level	PWM High Level	E_PWM	2.5	3.3	5.0	V	
	PWM Low Level		0	0	0.2	V	
PWM Control Frequency	fPWM	190	200	20k	Hz	(1)	
PWM Noise Range	VNoise	-	-	0.1	V		
PWM Control Duty Ratio	-	5		100	%	(1), Suggestion@ 190Hz ≤ fPWM < 1kHz	
		20		100	%	(1), @ 1kHz ≤ fPWM ≤ 20kHz	

Note (1) At 190 ~1kHz PWM control frequency, duty ratio range is restricted from 5% to 100%. 1K ~20kHz PWM control frequency, duty ratio range is restricted from 20% to 100%. If PWM control frequency is applied in the range from 1KHz to 20KHZ, The “non-linear” phenomenon on the Backlight Unit may be found. So It’s a suggestion that PWM control frequency should be less than 1KHz.

Power sequence and control signal timing are shown in the following figure

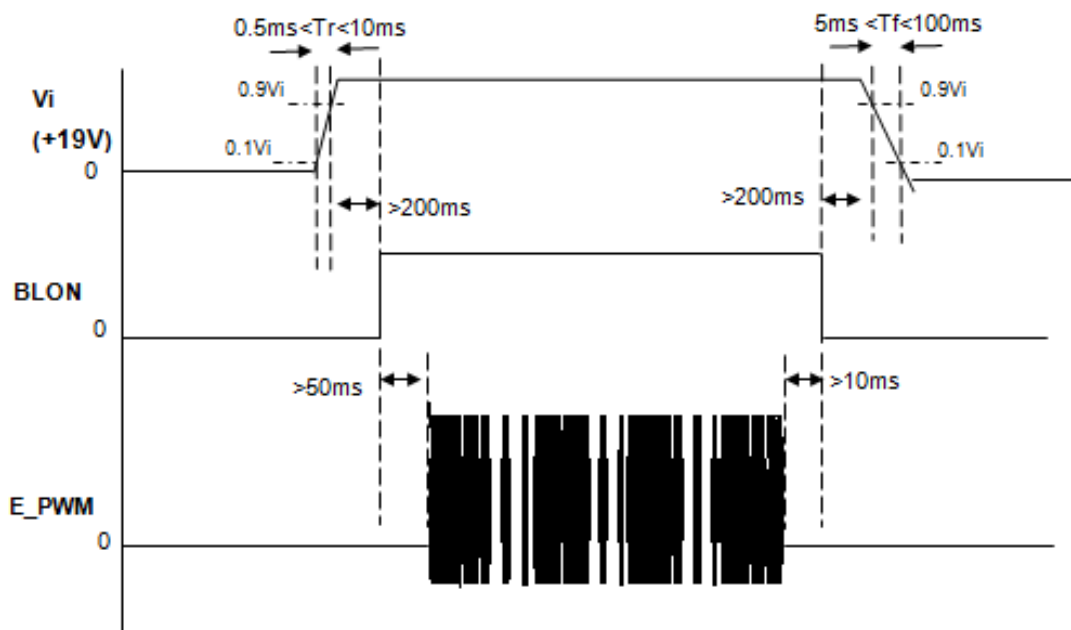

Note : While system is turned ON or OFF, the power sequences must follow as below descriptions

Turn ON sequence: Vi(+19V) → BLON → E_PWM signal

Turn OFF sequence: E_PWM signal → BLON → Vi(+19V)

The definition of T_r : the time period of 10%*Vi to 90%*Vi

The definition of T_f : the time period of 90%*Vi to 10%*Vi

4.3.5 CONVERTER INPUT CONNECTOR PIN ASSIGNMENT

Connector: CviLux CI4205M2HRP or equivalent.

Pin	Name	Description	Note
1	NC	NC	(1)
2	E_PWM	External PWM Control (Hi Level: DC 3.3V, Lo Level: 0V)	
3	EN	BL ON/OFF (ON:DC 3.3V, OFF:0V)	
4	GND	Ground	
5	Vi	DC +19V power supply	

Note (1) Pin 1 position please refer to the attached drawings for more information of front and back outline dimensions.

4.4 LVDS INPUT SIGNAL SPECIFICATIONS

4.4.1 LVDS DATA MAPPING TABLE

LVDS Channel O0	LVDS output	D7	D6	D4	D3	D2	D1	D0
	Data order	OG0	OR5	OR4	OR3	OR2	OR1	OR0
LVDS Channel O1	LVDS output	D18	D15	D14	D13	D12	D9	D8
	Data order	OB1	OB0	OG5	OG4	OG3	OG2	OG1
LVDS Channel O2	LVDS output	D26	D25	D24	D22	D21	D20	D19
	Data order	DE	NA	NA	OB5	OB4	OB3	OB2
LVDS Channel O3	LVDS output	D23	D17	D16	D11	D10	D5	D27
	Data order	NA	OB7	OB6	OG7	OG6	OR7	OR6
LVDS Channel E0	LVDS output	D7	D6	D4	D3	D2	D1	D0
	Data order	EG0	ER5	ER4	ER3	ER2	ER1	ER0
LVDS Channel E1	LVDS output	D18	D15	D14	D13	D12	D9	D8
	Data order	EB1	EB0	EG5	EG4	EG3	EG2	EG1
LVDS Channel E2	LVDS output	D26	D25	D24	D22	D21	D20	D19
	Data order	DE	NA	NA	EB5	EB4	EB3	EB2
LVDS Channel E3	LVDS output	D23	D17	D16	D11	D10	D5	D27
	Data order	NA	EB7	EB6	EG7	EG6	ER7	ER6

4.4.2 COLOR DATA INPUT ASSIGNMENT

The brightness of each primary color (red, green and blue) is based on the 8-bit gray scale data input for the color. The higher the binary input, the brighter the color. The table below provides the assignment of color versus data input.

Color		Data Signal																							
		Red								Green								Blue							
		R7	R6	R5	R4	R3	R2	R1	R0	G7	G6	G5	G4	G3	G2	G1	G0	B7	B6	B5	B4	B3	B2	B1	B0
Basic Colors	Black	0	0	0	0	0	0	0	0	0	0	0	0	0	0	0	0	0	0	0	0	0	0	0	0
	Red	1	1	1	1	1	1	1	1	0	0	0	0	0	0	0	0	0	0	0	0	0	0	0	0
	Green	0	0	0	0	0	0	0	0	1	1	1	1	1	1	1	1	0	0	0	0	0	0	0	0
	Blue	0	0	0	0	0	0	0	0	0	0	0	0	0	0	0	0	1	1	1	1	1	1	1	1
	Cyan	0	0	0	0	0	0	0	0	1	1	1	1	1	1	1	1	1	1	1	1	1	1	1	1
	Magenta	1	1	1	1	1	1	1	1	0	0	0	0	0	0	0	0	1	1	1	1	1	1	1	1
	Yellow	1	1	1	1	1	1	1	1	1	1	1	1	1	1	1	1	0	0	0	0	0	0	0	0
	White	1	1	1	1	1	1	1	1	1	1	1	1	1	1	1	1	1	1	1	1	1	1	1	1
Gray Scale Of Red	Red(0) / Dark	0	0	0	0	0	0	0	0	0	0	0	0	0	0	0	0	0	0	0	0	0	0	0	
	Red(1)	0	0	0	0	0	0	0	1	0	0	0	0	0	0	0	0	0	0	0	0	0	0	0	
	Red(2)	0	0	0	0	0	0	1	0	0	0	0	0	0	0	0	0	0	0	0	0	0	0	0	
	⋮	⋮	⋮	⋮	⋮	⋮	⋮	⋮	⋮	⋮	⋮	⋮	⋮	⋮	⋮	⋮	⋮	⋮	⋮	⋮	⋮	⋮	⋮	⋮	
	⋮	⋮	⋮	⋮	⋮	⋮	⋮	⋮	⋮	⋮	⋮	⋮	⋮	⋮	⋮	⋮	⋮	⋮	⋮	⋮	⋮	⋮	⋮	⋮	
	Red(253)	1	1	1	1	1	1	0	1	0	0	0	0	0	0	0	0	0	0	0	0	0	0	0	
	Red(254)	1	1	1	1	1	1	1	0	0	0	0	0	0	0	0	0	0	0	0	0	0	0	0	
	Red(255)	1	1	1	1	1	1	1	1	0	0	0	0	0	0	0	0	0	0	0	0	0	0	0	
Gray Scale Of Green	Green(0) / Dark	0	0	0	0	0	0	0	0	0	0	0	0	0	0	0	0	0	0	0	0	0	0	0	
	Green(1)	0	0	0	0	0	0	0	0	0	0	0	0	0	0	1	0	0	0	0	0	0	0	0	
	Green(2)	0	0	0	0	0	0	0	0	0	0	0	0	0	1	0	0	0	0	0	0	0	0	0	
	⋮	⋮	⋮	⋮	⋮	⋮	⋮	⋮	⋮	⋮	⋮	⋮	⋮	⋮	⋮	⋮	⋮	⋮	⋮	⋮	⋮	⋮	⋮	⋮	
	⋮	⋮	⋮	⋮	⋮	⋮	⋮	⋮	⋮	⋮	⋮	⋮	⋮	⋮	⋮	⋮	⋮	⋮	⋮	⋮	⋮	⋮	⋮	⋮	
	Green(253)	0	0	0	0	0	0	0	0	1	1	1	1	1	1	0	1	0	0	0	0	0	0	0	
	Green(254)	0	0	0	0	0	0	0	0	1	1	1	1	1	1	1	0	0	0	0	0	0	0	0	
	Green(255)	0	0	0	0	0	0	0	0	1	1	1	1	1	1	1	1	0	0	0	0	0	0	0	
Gray Scale Of Blue	Blue(0) / Dark	0	0	0	0	0	0	0	0	0	0	0	0	0	0	0	0	0	0	0	0	0	0	0	
	Blue(1)	0	0	0	0	0	0	0	0	0	0	0	0	0	0	0	0	0	0	0	0	0	0	1	
	Blue(2)	0	0	0	0	0	0	0	0	0	0	0	0	0	0	0	0	0	0	0	0	0	1	0	
	⋮	⋮	⋮	⋮	⋮	⋮	⋮	⋮	⋮	⋮	⋮	⋮	⋮	⋮	⋮	⋮	⋮	⋮	⋮	⋮	⋮	⋮	⋮	⋮	
	⋮	⋮	⋮	⋮	⋮	⋮	⋮	⋮	⋮	⋮	⋮	⋮	⋮	⋮	⋮	⋮	⋮	⋮	⋮	⋮	⋮	⋮	⋮	⋮	
	Blue(253)	0	0	0	0	0	0	0	0	0	0	0	0	0	0	0	1	1	1	1	1	1	1	0	
	Blue(254)	0	0	0	0	0	0	0	0	0	0	0	0	0	0	0	1	1	1	1	1	1	1	0	
	Blue(255)	0	0	0	0	0	0	0	0	0	0	0	0	0	0	0	1	1	1	1	1	1	1	1	

Note (1) 0: Low Level Voltage, 1: High Level Voltage

4.5 DISPLAY TIMING SPECIFICATIONS

The input signal timing specifications are shown as the following table and timing diagram.

Signal	Item	Symbol	Min.	Typ.	Max.	Unit	Note
LVDS Clock	Frequency	Fc	58.54	74.25	97.98	MHz	-
	Period	Tc	-	13.47	-	ns	
	Input cycle to cycle jitter	T _{rcj}	-0.02*TC	-	0.02*TC	ns	(1)
	Input Clock to data skew	TLVCCS	-0.02*TC		0.02*TC		(2)
	Spread spectrum modulation range	F _{ckin_mod}	0.97*FC	-	1.03*TC	MHz	(3)
	Spread spectrum modulation frequency	F _{SSM}	-	-	100	KHz	
Vertical Display Term	Frame Rate	Fr	50	60	75	Hz	
	Total	Tv	1115	1125	1136	Th	Tv=Tvd+Tvb-
	Active Display	Tvd	1080	1080	1080	Th	-
	Blank	Tvb	Tv-Tvd	Tv-Tvd	Tv-Tvd	Th	-
Horizontal Display Term	Total	Th	1050	1100	1150	Tc	Th=Thd+Thb
	Active Display	Thd	960	960	960	Tc	-
	Blank	Thb	Th-Thd	Th-Thd	Th-Thd	Tc	-

Note: Because this module is operated by DE only mode, Hsync and Vsync input signals are ignored.

INPUT SIGNAL TIMING DIAGRAM

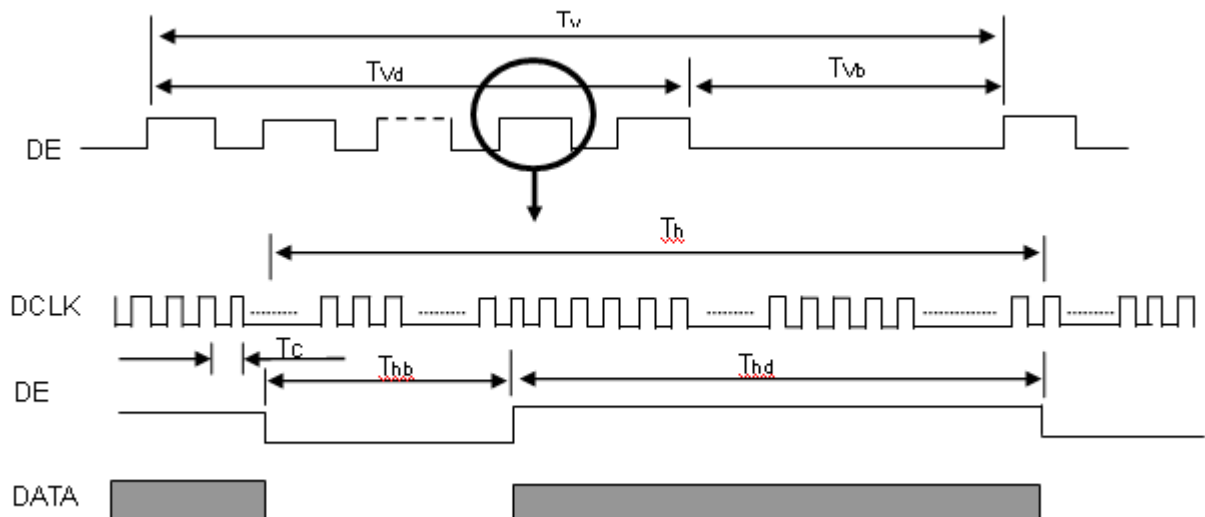

Note (1) The input clock cycle-to-cycle jitter is defined as below figures. $Trcl = |T_1 - T_1'|$

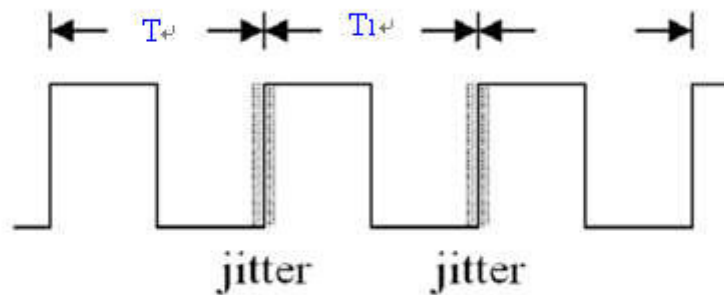

Note (2) Input Clock to data skew is defined as below figures.

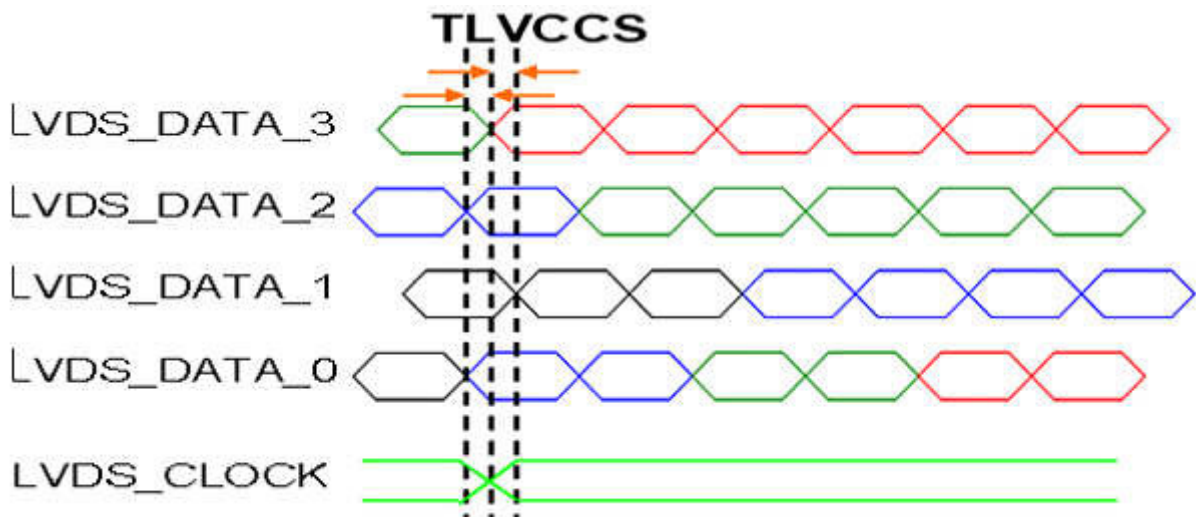

Note (3) The SSCG (Spread spectrum clock generator) is defined as below figures.

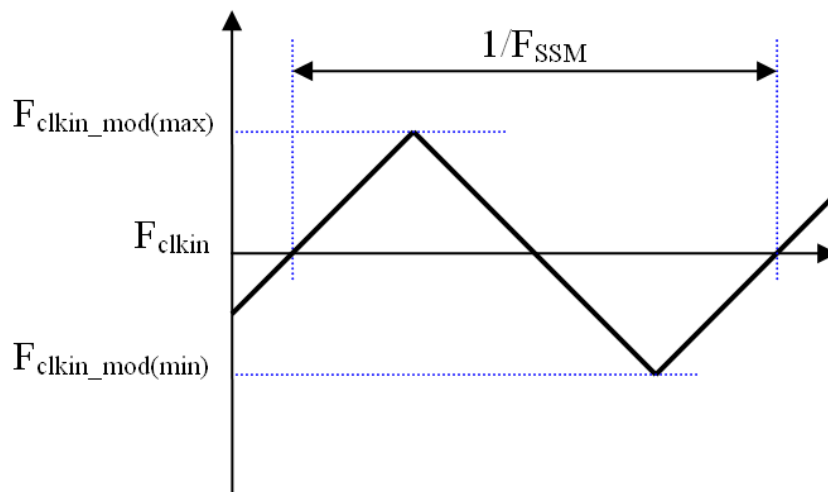

Note(4) The DCLK range at last line of V-blank should be set in 0 to Hdisplay/2

4.6 POWER ON/OFF SEQUENCE

The power sequence specifications are shown as the following table and diagram.

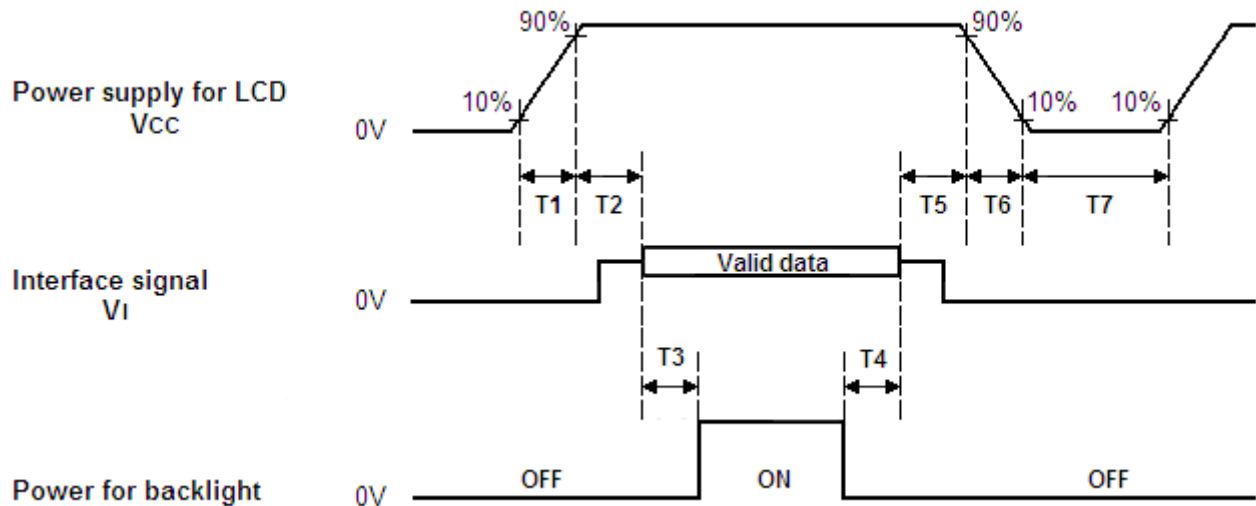

Timing Specifications:

Parameters	Values			Units
	Min	Typ.	Max	
T1	0.5	--	10	ms
T2	0	30	50	ms
T3	450	--	--	ms
T4	100	250	--	ms
T5	0	20	50	ms
T6	0.1	--	100	ms
T7	1000	--	--	ms

Note (1) The supply voltage of the external system for the module input should be the same as the definition of Vcc.

Note (2) When the backlight turns on before the LCD operation of the LCD turns off, the display may momentarily become abnormal screen.

Note (3) In case of VCC = off level, please keep the level of input signals on the low or keep a high impedance.

Note (4) T7 should be measured after the module has been fully discharged between power off and on period.

Note (5) Interface signal shall not be kept at high impedance when the power is on.

Note (6) INX won't take any responsibility for the products which are damaged by the customers not following the Power Sequence.

Note (7) There might be slight electronic noise when LCD is turned off (even backlight unit is also off). To avoid this symptom, we suggest "Vcc falling timing" to follow "t6 spec".

5. OPTICAL CHARACTERISTICS

5.1 TEST CONDITIONS

Item	Symbol	Value	Unit
Ambient Temperature	Ta	25 ± 2	°C
Ambient Humidity	Ha	50 ± 10	%RH
Supply Voltage	V _{CC}	5	V
Input Signal	According to typical value in "3. ELECTRICAL CHARACTERISTICS"		
LED Light Bar Input Current Per Input Pin	According to typical value in "3. ELECTRICAL CHARACTERISTICS"		
PWM Duty Ratio	D	100	%

5.2 OPTICAL SPECIFICATIONS

The relative measurement methods of optical characteristics are shown in 5.2. The following items should be measured under the test conditions described in 5.1 and stable environment shown in Note (5).

Item	Symbol	Condition	Min.	Typ.	Max.	Unit	Note	
Color Chromaticity (CIE 1931)	Red	Rx	(Typ - 0.05)	0.644	(Typ + 0.05)	-	(1), (5)	
		Ry		0.338				
	Green	Gx		0.316				
		Gy		0.616				
	Blue	Bx		0.150				
		By		0.056				
	White	Wx		0.313				
		Wy		0.329				
Center Luminance of White	L _C		360	450	-	cd/m ²	(4), (5)	
Contrast Ratio	CR		2000	3000	-	-	(2), (5)	
Response Time	T _R			15	20	ms	(3)	
	T _F			5	10	ms	(3)	
	T _{GtG_AVE}	θ _x =0°, θ _y =0°	-	25	30	ms	(3)	
White Variation	W	θ _x =0°, θ _y =0°	70	75	-	%	(5), (6)	
Viewing Angle	Horizontal	θ _{x+}	CR ≥ 10	80	85	---	Deg.	(1), (5)
		θ _{x-}		80	85			
	Vertical	θ _{y+}		80	85			
		θ _{y-}		80	85	---		

Note (1) Definition of Viewing Angle (θ_x , θ_y):

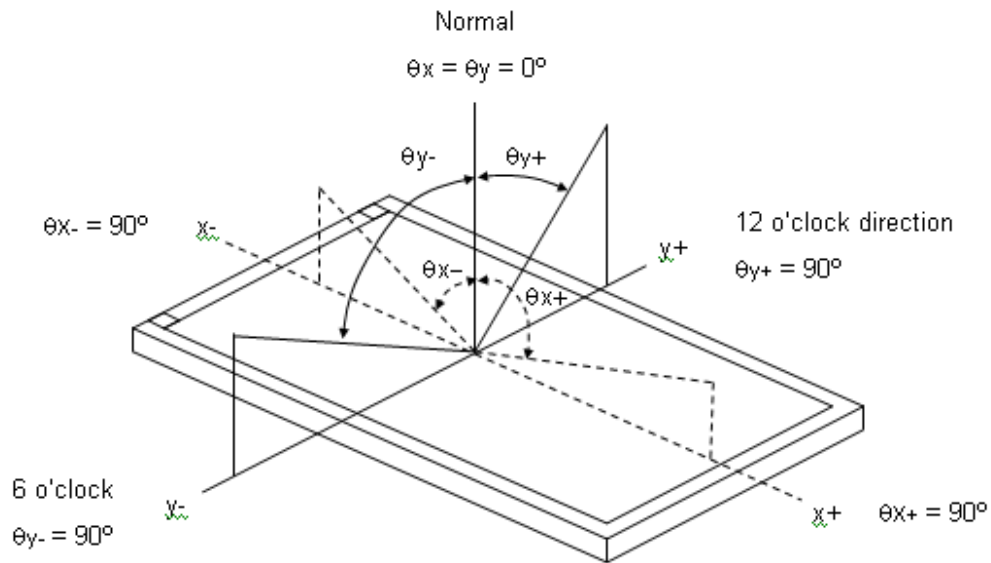

Note (2) Definition of Contrast Ratio (CR):

The contrast ratio can be calculated by the following expression.

$$\text{Contrast Ratio (CR)} = L_{255} / L_0$$

L255: Luminance of gray level 255

L 0: Luminance of gray level 0

$$\text{CR} = \text{CR} (5)$$

CR (X) is corresponding to the Contrast Ratio of the point X at Figure in Note (6).

Note (3) Definition of Response Time (T_R , T_F) and measurement method:

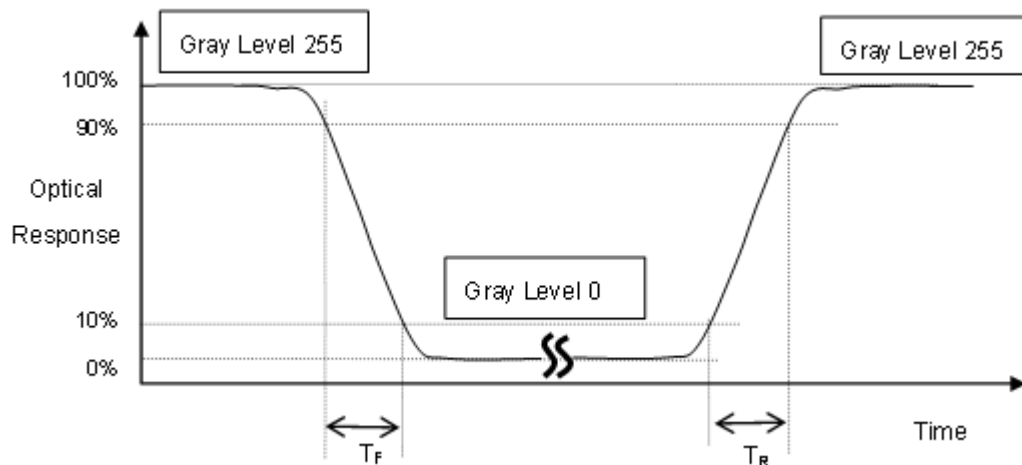

Definition of Response Time (T_{GTG_AVE}) :

T_{GTG_AVE} is defined as the total average response time for “Gray To Gray”.

The Gray to Gray response time is defined as the following chart.

Gray to Gray		Rising time								
		0	31	63	95	127	159	191	223	255
Falling time	0									
	31									
	63									
	95									
	127									
	159									
	191									
	223									
	255									

Note (4) Definition of Luminance of White (L_C):

Measure the luminance of gray level 255 at center point

$$L_C = L(5)$$

$L(x)$ is corresponding to the luminance of the point X at Figure in Note (6).

Note (5) Measurement Setup:

The LCD module should be stabilized at given temperature for (40 minutes) to avoid abrupt temperature change during measuring. In order to stabilize the luminance, the measurement should be executed after lighting Backlight for (40 minutes) in a windless room.

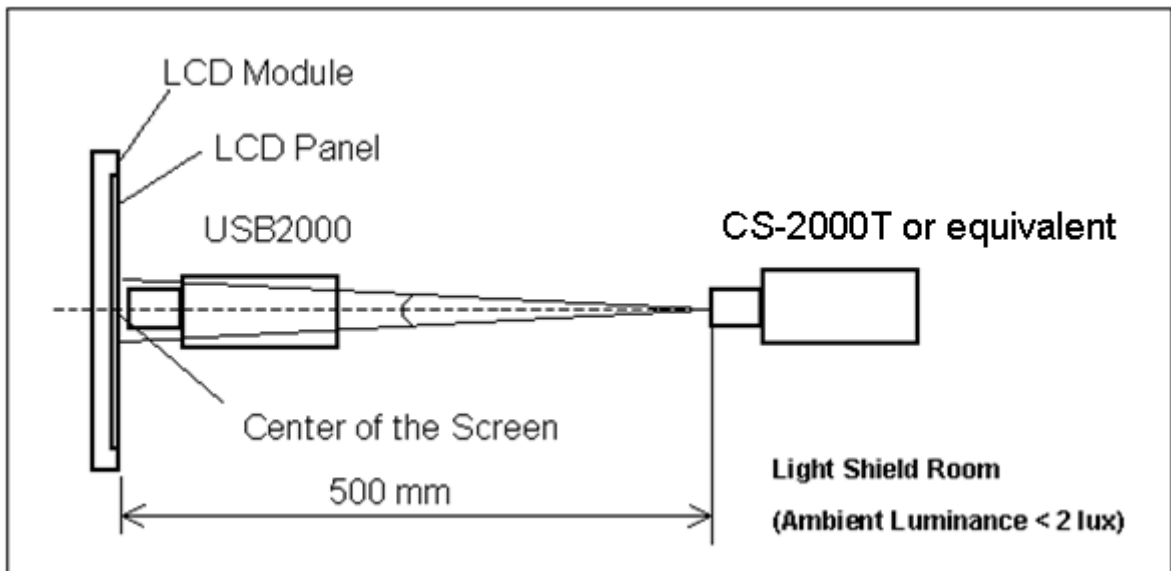

Note (6) Definition of White Variation (δW):

Measure the luminance of gray level 255 at 9 points

$$\delta W = (\text{Minimum } [L(1) \sim L(9)] / \text{Maximum } [L(1) \sim L(9)]) * 100\%$$

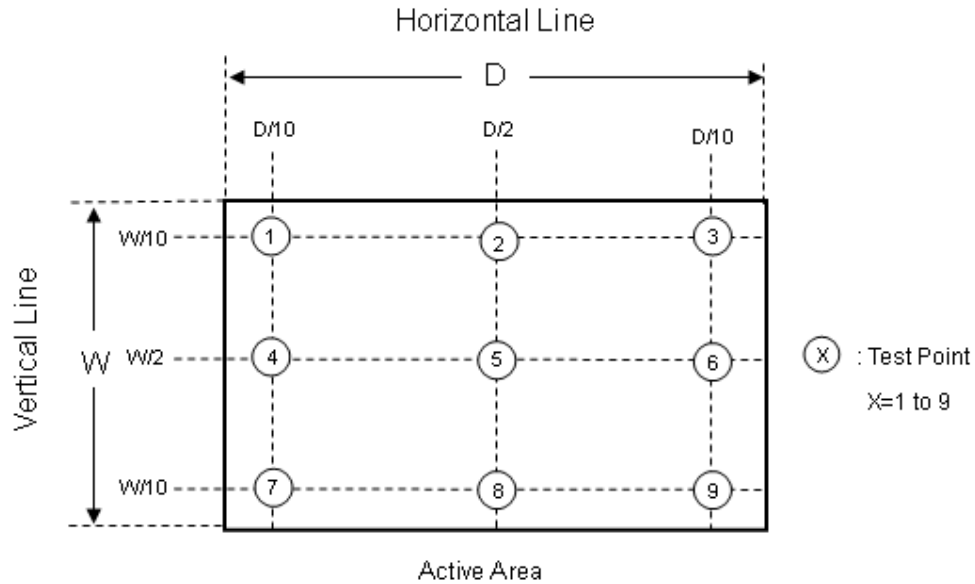

6. RELIABILITY TEST ITEM

Items	Required Condition	Note
Temperature Humidity Bias (THB)	Ta= 50°C , 80%RH, 240hours	1)(2)(4)(5)
High Temperature Operation (HTO)	Ta= 50°C , 240hours	(1)(2)(4)
Low Temperature Operation (LTO)	Ta= 0°C , 240hours	
High Temperature Storage (HTS)	Ta= 60°C , 240hours	
Low Temperature Storage (LTS)	Ta= -20°C , 240hours	
Thermal Shock Test (TST)	-20°C/30min , 60°C / 30min , 100 cycles	
Vibration Test (Non-operation)	Acceleration: 1.5 G Wave: Sine Frequency: 10 - 300 Hz Sweep: 30 Minutes each Axis (X, Y, Z)	(1)(3)
Shock Test (Non-operation)	Acceleration: 50 G Wave: Half-sine Active Time: 11 ms Direction : ± X, ± Y, ± Z.(one time for each Axis)	

Note (1) criteria : Normal display image with no obvious non-uniformity and no line defect.

Note (2) Evaluation should be tested after storage at room temperature for more than two hour

Note (3) At testing Vibration and Shock, the fixture in holding the module has to be hard and rigid enough so that the module would not be twisted or bent by the fixture.

Note (4) In the standard conditions, there is no function failure issue occurred. All the cosmetic specification is judged before reliability test.

Note (5) Before cosmetic and function test, the product must have enough recovery time, at least 24 hours at room temperature.

7. PACKING

7.1 PACKING SPECIFICATIONS

- (1) 15 LCD modules / 1 Box
- (2) Box dimensions: 540(L)*395(W)*355(H)mm
- (3) Weight: approximately: 26.5kg (15 modules per box)

7.2 PACKING METHOD

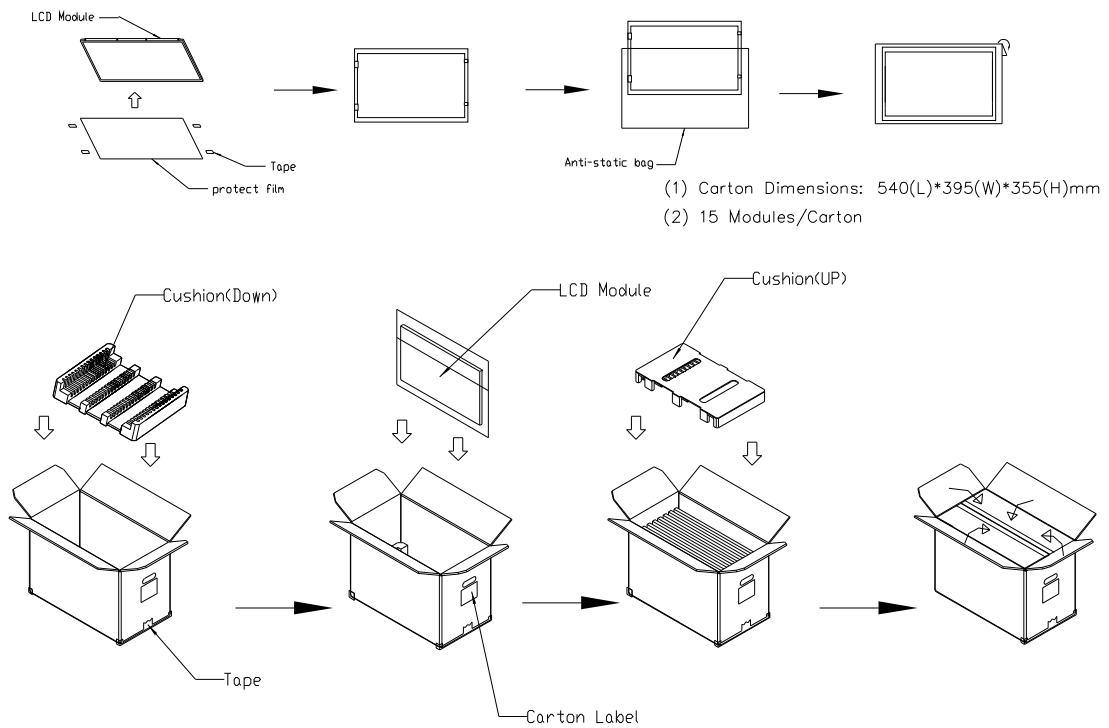

Figure. 7-1 Packing method

7.3 PALLET

For ocean shipping

Sea / Land Transportation (40ft HQ Container)

Sea / Land Transportation (40ft Container)

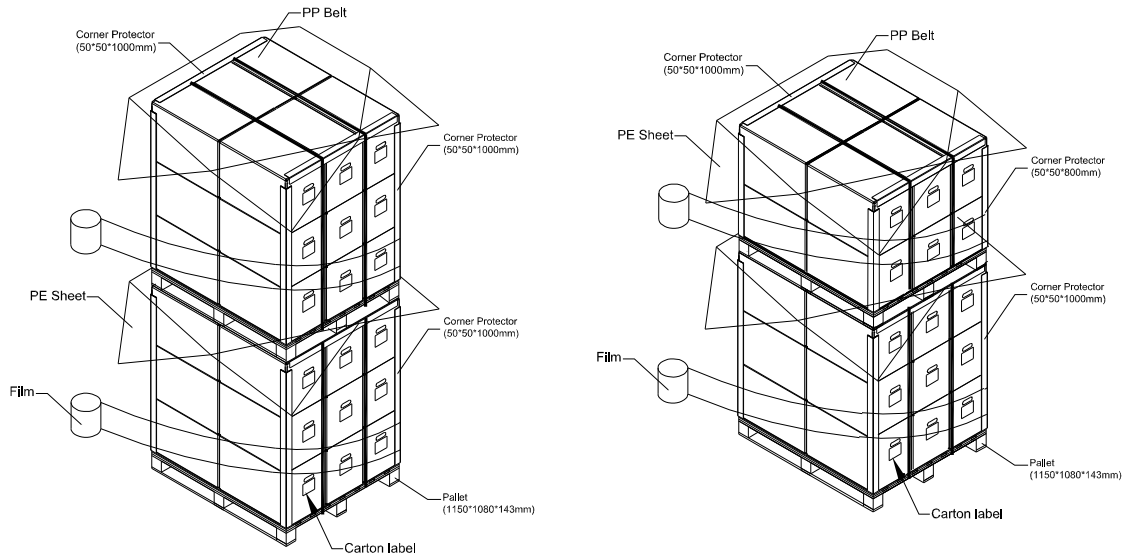

For air transport

Air Transportation

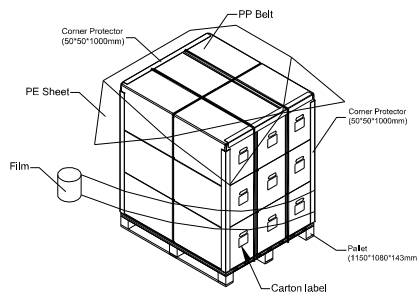

Figure. 7-2 Packing method

7.4 UN-PACKING METHOD

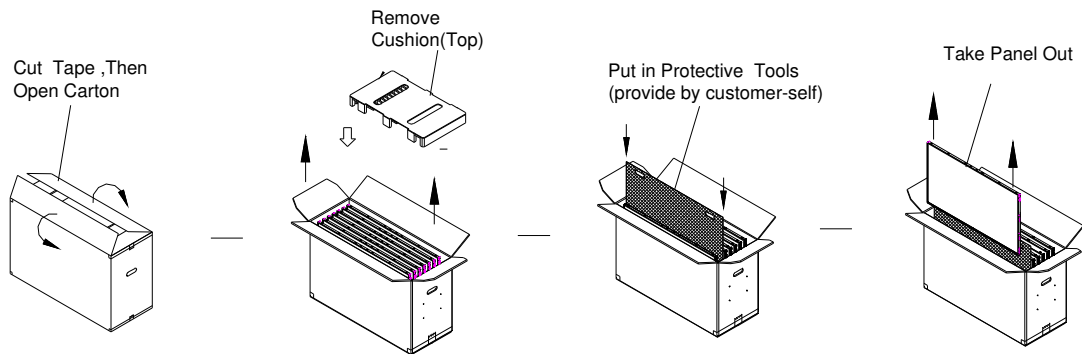
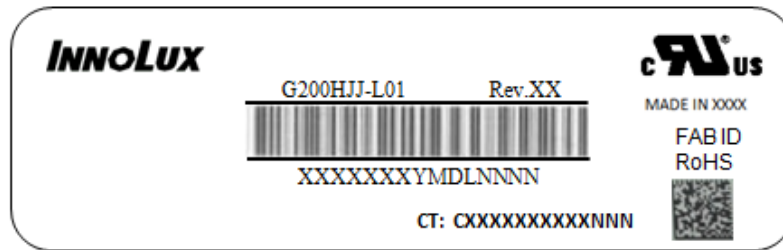

Figure. 7-3 Un-Packing method

8. INX MODULE LABEL

The barcode nameplate is pasted on each module as illustration, and its definitions are as following explanation.



(a) Model Name: G200HJJ-L01

(b) Revision: Rev. XX, for example: A0, A1... B1, B2... or C1, C2...etc.

(c) INX barcode definition:

Serial ID: XX-XX-X-XX-YMD-L-NNNN

Code	Meaning	Description
XX	INX internal use	-
XX	Revision	Cover all the change
X	INX internal use	-
XX	INX internal use	-
YMD	Year, month, day	Year: 0~9, 2011=1, 2012=2, 2013=3, 2014=4..... Month: 1~12=1, 2, 3, ~, 9, A, B, C Day: 1~31=1, 2, 3, ~, 9, A, B, C, ~, W, X, Y, exclude I, O, and U.
L	Product line #	Line 1=1, Line 2=2, Line 3=3, ...
NNNN	Serial number	Manufacturing sequence of product

(e) CT barcode definition:

Serial ID: CT: C-XXXX-XX-XX-WW-NNN

Code	Meaning	Description
CT:	Title	-
C	LCD display module	-
XXXX	Assembly code	N-ZBD/ZBD: XXXX
XX	Revision	Cover all the change
XX	Supplier /Site of MFG	NB B : K5/7P/K6/8K/6X/4Z/5C
XX	Week/Year of MFG	-
NNN	Unique Sequence Identifier	001~ZZZ

(d) FAB ID(UL Factory ID):

Region	Factory ID
TWINX	GEMN
NBINX	LEOO
NBINX	VIRO
NBCME	COCKN
NHINX	CAPG

9. PRECAUTIONS

9.1 ASSEMBLY AND HANDLING PRECAUTIONS

- (1) Do not apply rough force such as bending or twisting to the module during assembly.
- (2) It is recommended to assemble or to install a module into the user's system in clean working areas. The dust and oil may cause electrical short or worsen the polarizer.
- (3) Do not apply pressure or impulse to the module to prevent the damage of LCD panel and Backlight.
- (4) Always follow the correct power-on sequence when the LCD module is turned on. This can prevent the damage and latch-up of the CMOS LSI chips.
- (5) Do not plug in or pull out the I/F connector while the module is in operation.
- (6) Do not disassemble the module.
- (7) Use a soft dry cloth without chemicals for cleaning, because the surface of polarizer is very soft and easily scratched.
- (8) Moisture can easily penetrate into LCD module and may cause the damage during operation.
- (9) High temperature or humidity may deteriorate the performance of LCD module. Please store LCD modules in the specified storage conditions.
- (10) When ambient temperature is lower than 10°C, the display quality might be reduced. For example, the response time will become slow, and the starting voltage of backlight will be higher than that of room temperature.
- (11) Do not keep same pattern in a long period of time. It may cause image sticking on LCD.

9.2 SAFETY PRECAUTIONS

- (1) The startup voltage of a Backlight is approximately 1000 Volts. It may cause an electrical shock while assembling with the inverter. Do not disassemble the module or insert anything into the Backlight unit.
- (2) If the liquid crystal material leaks from the panel, it should be kept away from the eyes or mouth. In case of contact with hands, skin or clothes, it has to be washed away thoroughly with soap.
- (3) After the module's end of life, it is not harmful in case of normal operation and storage.

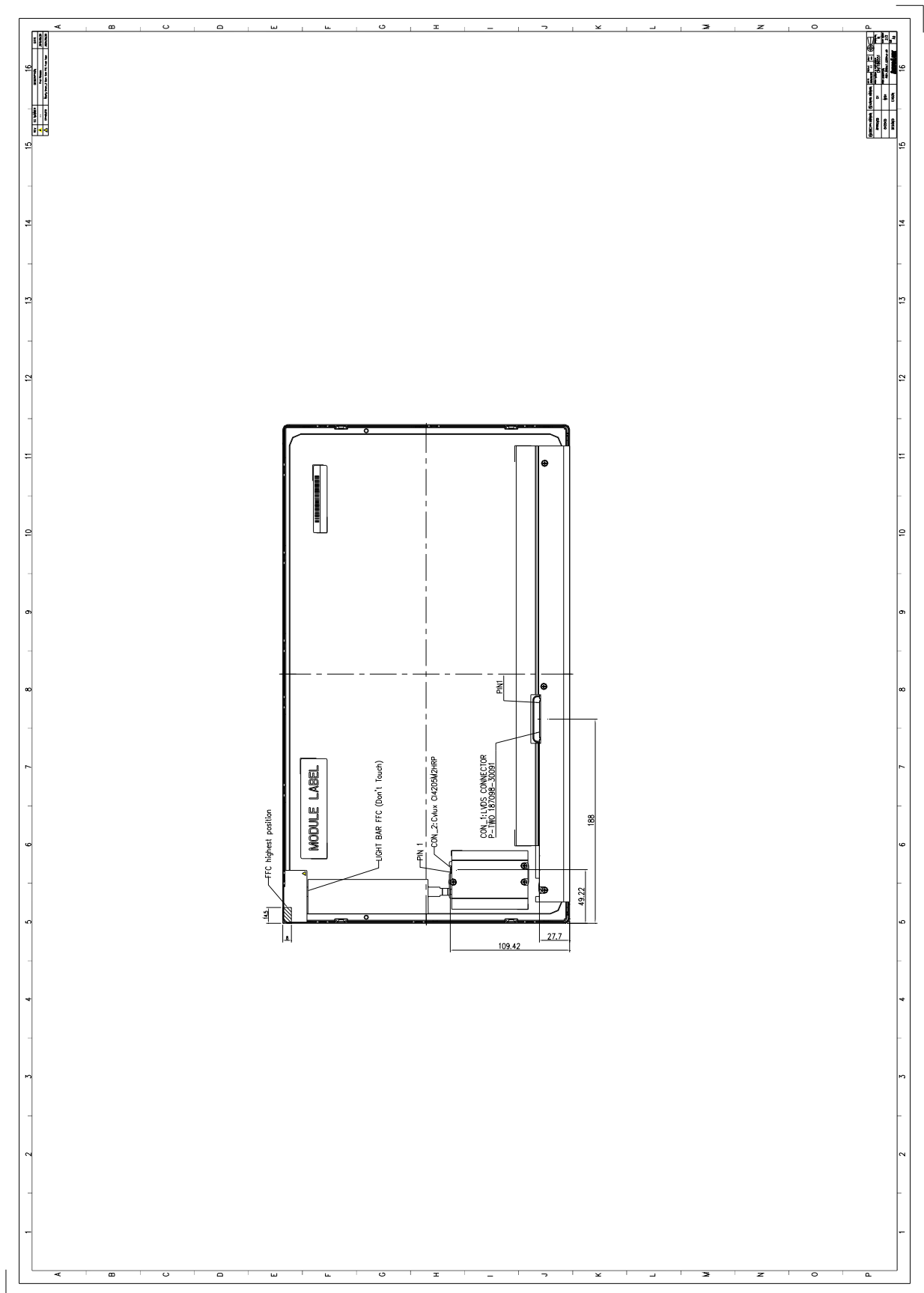



ALL TECHNOLOGIES. ALL COMPETENCIES. ONE SPECIALIST.



DATA MODUL AG
Landsberger Straße 322 DE-
80687 Munich
Phone: +49-89-56017-0

DATA MODUL WEIKERSHEIM GMBH
Lindenstraße 8
DE-97990 Weikersheim Phone:
+49-7934-101-0



More information and worldwide locations can be found at

www.data-modul.com