

TO : Customer

DATE : 2024.07.22

**GREEN C&C TECH Co.,Ltd
75, Saneop-ro 92beon-gil,
Gwonseon-gu, Suwon-si, Gyeonggi-do
KOREA 16643
TEL : 82-31-373-3623~3625
FAX : 82-31-373-3610**

DOCUMENTATION FOR APPROVAL

PRODUCT : LED BACKLIGHT DRIVER (RoHS)

MODEL NAME : GH766A(A11)

GCCT NAME : GCCT766AL

APPROVAL	CHECKED	WRITTEN

PLEASE RETURN ONE DOCUMENT AFTER APPROVED SIGN.

GREEN C&C TECH	LED DRIVER SPECIFICATION GH766A(A11)	Publishing Date	2024.07.22
		Reforming Date	

NO	Date	REVISION	Page
REVISION HISTORY			

REV.														
Page														
REV.	0	0	0	0	0	0	0	0	0	0	0	0	0	0
Page	1	2	3	4	5	6	7	8	9	10	11	12	13	14
											Page Rev.	0	Page	1

GREEN C&C TECH	LED DRIVER SPECIFICATION GH766A(A11)	Publishing Date	2024.07.22
		Reforming Date	

1. APPLICATION

This Document Specified The Detailed Product Requirement of LED driver
GH766A(A11)

2. SUITABLE LOAD

LCD MODULE : 4 Strings LED BLU TFT LCD

3. ELECTRICAL CHARATERISTICS

3.1. Absolute Maximum Ratings

Item	Symbol	Spec.	Unit	Remarks
Input Voltage 1	Vin	10.8~26.4	V	
Input Voltage 2	ON/OFF	5.25	V	
Operating Temperature	Top	-20~70	℃	
Storage Temperature	Tstg	-30~80	℃	
Relative Humidity	RH	80	%	

3.2. Control Signal

PIN No.	Symbol	Status	Action	Remarks
CN1 #9	ON/OFF	HIGH	LED - ON	2.4 ~ 5.0V
		LOW	LED - OFF	0.8 V Max

GREEN C&C TECH	LED DRIVER SPECIFICATION GH766A(A11)	Publishing Date	2024.07.22
		Reforming Date	

3.3. Output Characteristics

Item	Sym.	Condition	Min.	Typ.	Max.	Unit
Input Voltage	Vin	-	10.8	-	26.4	Vdc
Input Current	Iin	Vin=12V or 24V, Dim=0V	-	-	2.0	A
Output Current	Iout (Max)	Vin=12V or 24V, Dim=0V	80.0	90.0	100.0	mAmean
	Iout (Min)	Vin=12V or 24V, Dim=5V	15.0	20.0	25.0	
Backlight ON/OFF Control	ON	-	2.4	-	5.0	Vdc
	OFF	-	-0.3	-	0.8	

* Output Voltage is greater than Input Voltage for at least 3V or more.

3.4. Test Circuit

- S/W : A --> BLU ON
- B --> BLU OFF

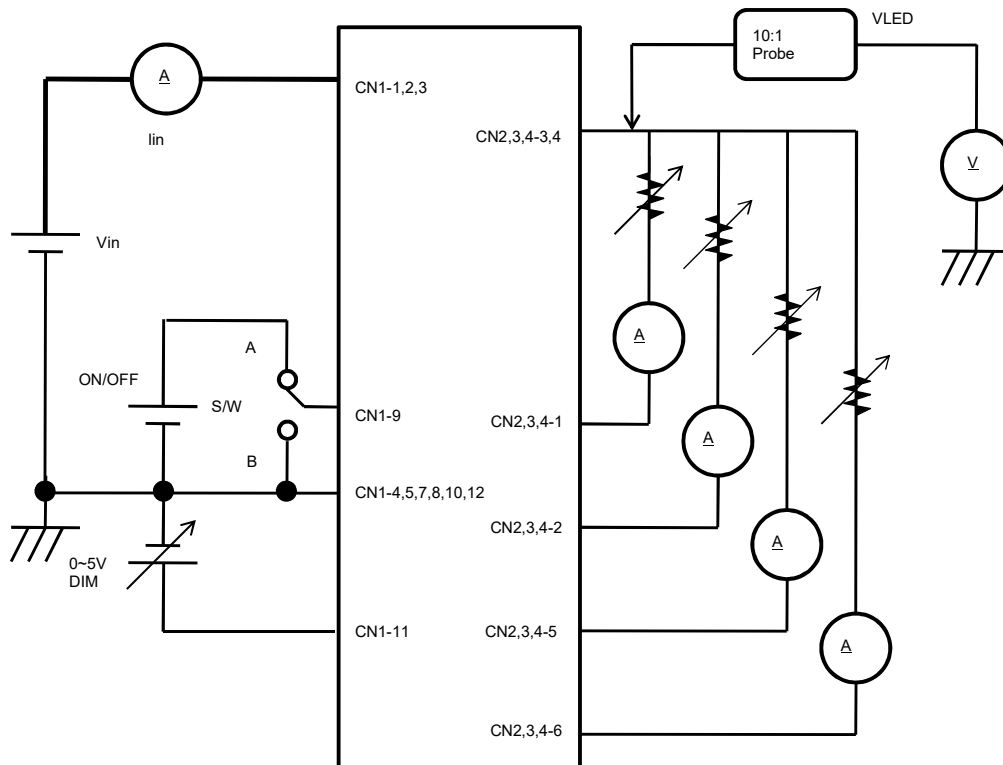

GREEN C&C TECH	LED DRIVER SPECIFICATION GH766A(A11)	Publishing Date	2024.07.22
		Reforming Date	

4. INTERFACE

4.1. CN1 Connector (Input) : 12505WR-12A (YEONHO) or Equivalent

PIN No.	Symbol	Description
1,2,3	VIN	Voltage Input : 12V, 24V (typ.)
4,5,7,8,10,12	GND	Ground
6	N.C	No Connection
9	ON/OFF	LED DRIVER ON/OFF Control
11	DIM	0V(MAX)~5V(MIN)

4.2. CN2 Connector (Output) : 12507WR-06L (YEONHO) or Equivalent

PIN No.	Symbol	Description
1	FB1	Feedback 1 (Return 1)
2	FB2	Feedback 2 (Return 2)
3	VLED	System Output
4	VLED	System Output
5	FB3	Feedback 3 (Return 3)
6	FB4	Feedback 4 (Return 4)

4.3. CN3 Connector (Output) : 10019HR-H06B (YEONHO) or Equivalent

PIN No.	Symbol	Description
1	FB1	Feedback 1 (Return 1)
2	FB2	Feedback 2 (Return 2)
3	VLED	System Output
4	VLED	System Output
5	FB3	Feedback 3 (Return 3)
6	FB4	Feedback 4 (Return 4)

4.4. CN4 Connector (Output) : 05002HR-H06CE (YEONHO) or Equivalent

PIN No.	Symbol	Description
1	FB1	Feedback 1 (Return 1)
2	FB2	Feedback 2 (Return 2)
3	VLED	System Output
4	VLED	System Output
5	FB3	Feedback 3 (Return 3)
6	FB4	Feedback 4 (Return 4)

GREEN C&C TECH	LED DRIVER SPECIFICATION GH766A(A11)	Publishing Date Reforming Date	2024.07.22
----------------	---	-----------------------------------	------------

5. APPERANCE (Unit : mm)

(Tolerance : +0.8mm, -0.2mm)

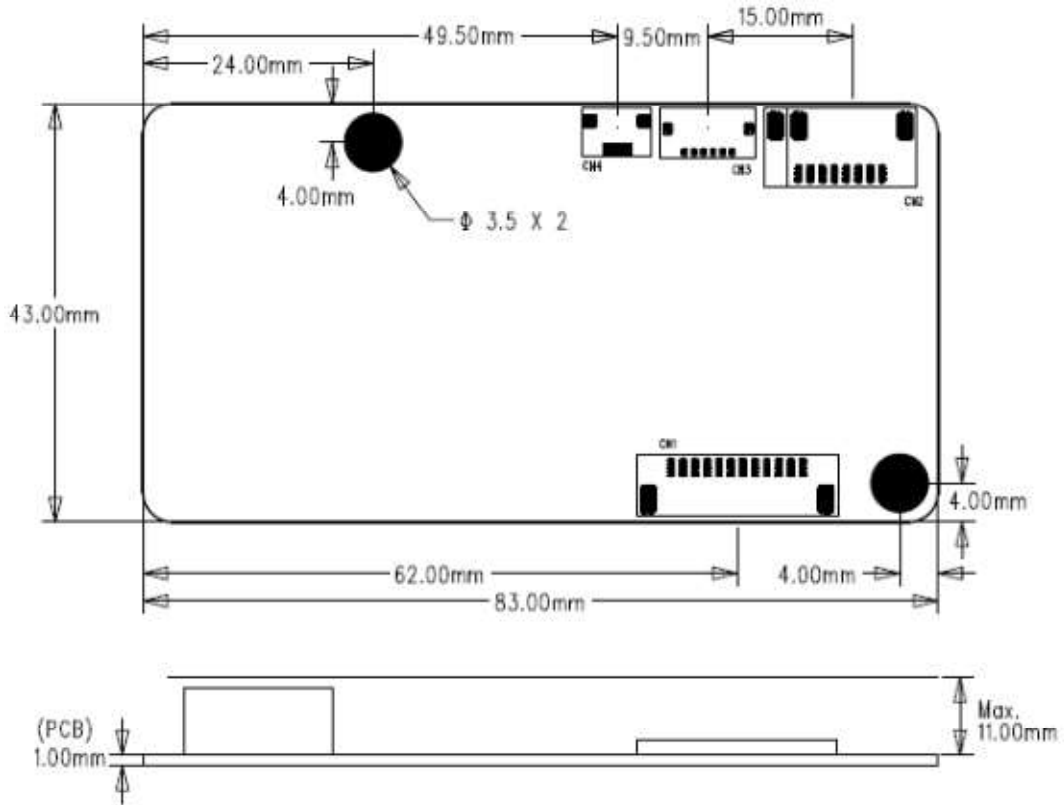

6. NOTATION OF LOT NUMBER

MARKING:BOTTOM

	GH766A(A11)	→ ① USER MODEL CODE
	G20 01A	→ ② PRODUCTION MANAGEMENT CODE
	0001 AL	→ ③ SERIAL NUMBER & CONTROL CODE

①	GH766A(A11)	: USER MODEL CODE
	G	: MANUFACTURER CODE (GREEN C&C TECH)
	20	: YEAR OF PRODUCT 20 → 2020 , 21 → 2021 , ... , 29 → 2029
②	01	: WEEK OF PRODUCT 01,02,03,04,...52
	A	: PUBLICATION NUMBER A,B,C,...,Z,0,1,2,...,9
③	0001	: SERIAL NUMBER 0001,0002.....9998,9999
	AL	: GCCT CONTROL MODEL CODE

GREEN C&C TECH	LED DRIVER SPECIFICATION GH766A(A11)	Publishing Date	2024.07.22
		Reforming Date	

7. PART LIST

SYMBOL	NAME	1st		2nd	
		TYPE No	MAKER	TYPE No	MAKER
U1	IC	MP3391EF	MPS		
Q1	FET	AP9997GH	APEC	Equivalent	
Q2	TR	MMBT2907A	DIODES	Equivalent	
D1,D2	DIODE	B2100	DIODES	Equivalent	
C1	C-ELEC	BXJ Series 220uF/35V	SAMYOUNG	Equivalent	
C16		BXJ Series 10uF/100V	SAMYOUNG	"	
C2,C4	MLCC	CL21A225KA	SEMCO	Equivalent	
C3		CL21B105KB	"	"	
C5,C6,C8		CL10A105KA	"	"	
C7		CL10B102KB	"	"	
C9		CL10B104KB	"	"	
C14		CL10C101JB	"	"	
C15		CL31B105KC	"	"	
R1		CHIP-R	RM10JTN100	TA-I Tech	Equivalent
R3,R12	RM06JTN224		"	"	
R4,R5	RM06JTN513		"	"	
R6,R9,R19, R25,R26	RM06JTN104		"	"	
R7	RM06JTN124		"	"	
R10	RM06JTN273		"	"	
R11	RM06JTN102		"	"	
R13	RM06JTN184		"	"	
R14	RM06JTN393		"	"	
R15	RM06JTN203		"	"	
R17	RM06JTN101		"	"	
R18	RM06JTN100		"	"	
R20,R21	RL12FTNR200		"	"	
R27	RM06JTN362		"	"	

GREEN C&C TECH	LED DRIVER SPECIFICATION GH766A(A11)	Publishing Date	2024.07.22
		Reforming Date	

SYMBOL	NAME	1st		2nd	
		TYPE No	MAKER	TYPE No	MAKER
F1	FUSE	CCF1N4	KOA	CB61F4A	Cooper Bussmann
		451004	LITTELFUSE	453004	LITTELFUSE
L1	Inductor	SPI-1580SDM-470	SEJIN	Equivalent	
L2		SFCB7050-100	SAMWHA TECOM	"	
CN1	Connector	12505WR-12A	YEONHO	Equivalent	
CN2		12507WR-06L	YEONHO	"	
CN3		10019HR-H06B	YEONHO	"	
CN4		05002HR-H06CE	YEONHO	"	
PCB	PCB	GH766A REV0.0	SEOKANG	GH766A REV0.0	DAUN ENG
		GH766A REV0.0	AMC KOREA	GH766A REV0.0	SKY TECHNOLOGY

GREEN C&C TECH	LED DRIVER SPECIFICATION GH766A(A11)	Publishing Date Reforming Date	2024.07.22
----------------	---	-----------------------------------	------------

8. PCB LAYOUT

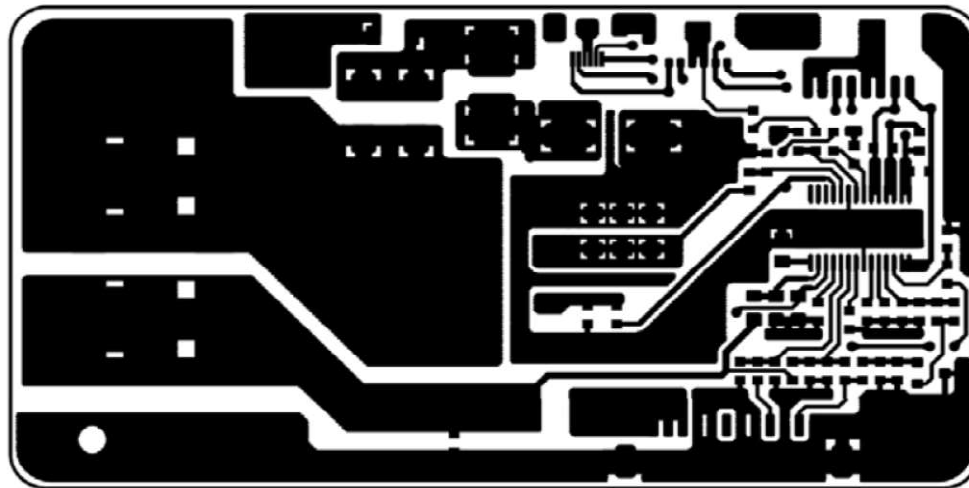

TOP LAYER

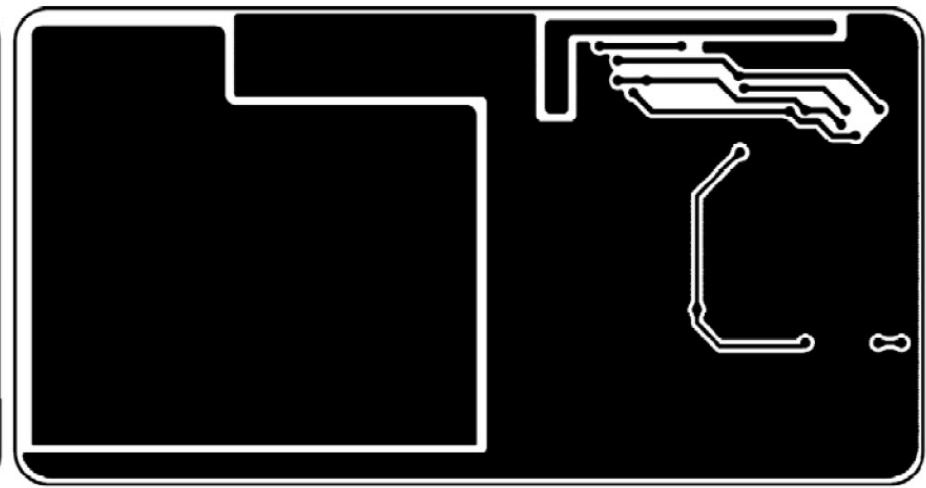

BOTTOM LAYER

GREEN C&C TECH

LED DRIVER SPECIFICATION

GH766A(A11)

Publishing Date
Reforming Date

2024.07.22

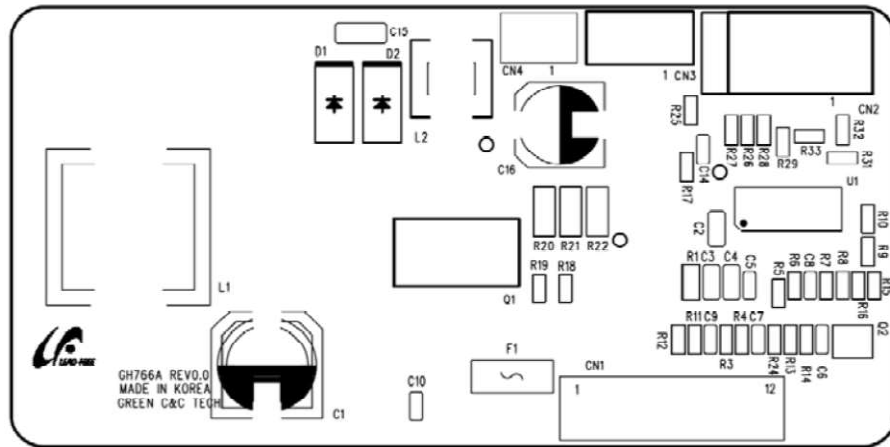

SILK SCREEN TOP

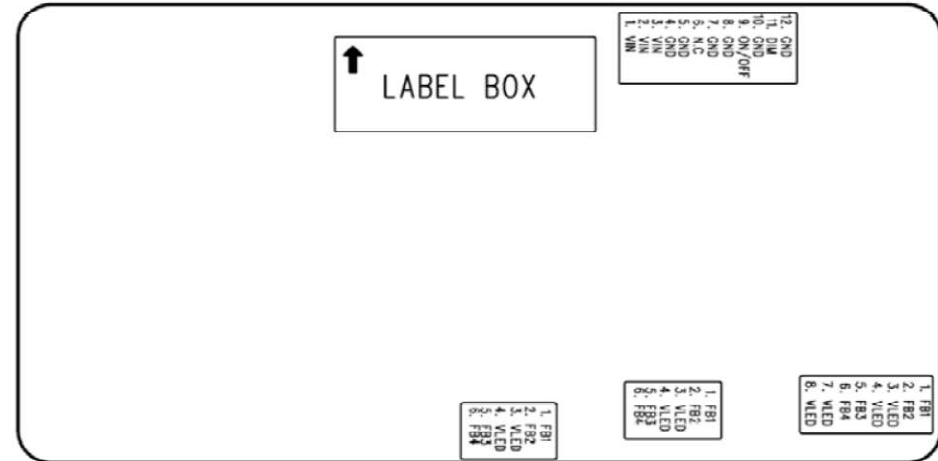

SILK SCREEN BOTTOM

9. CIRCUIT

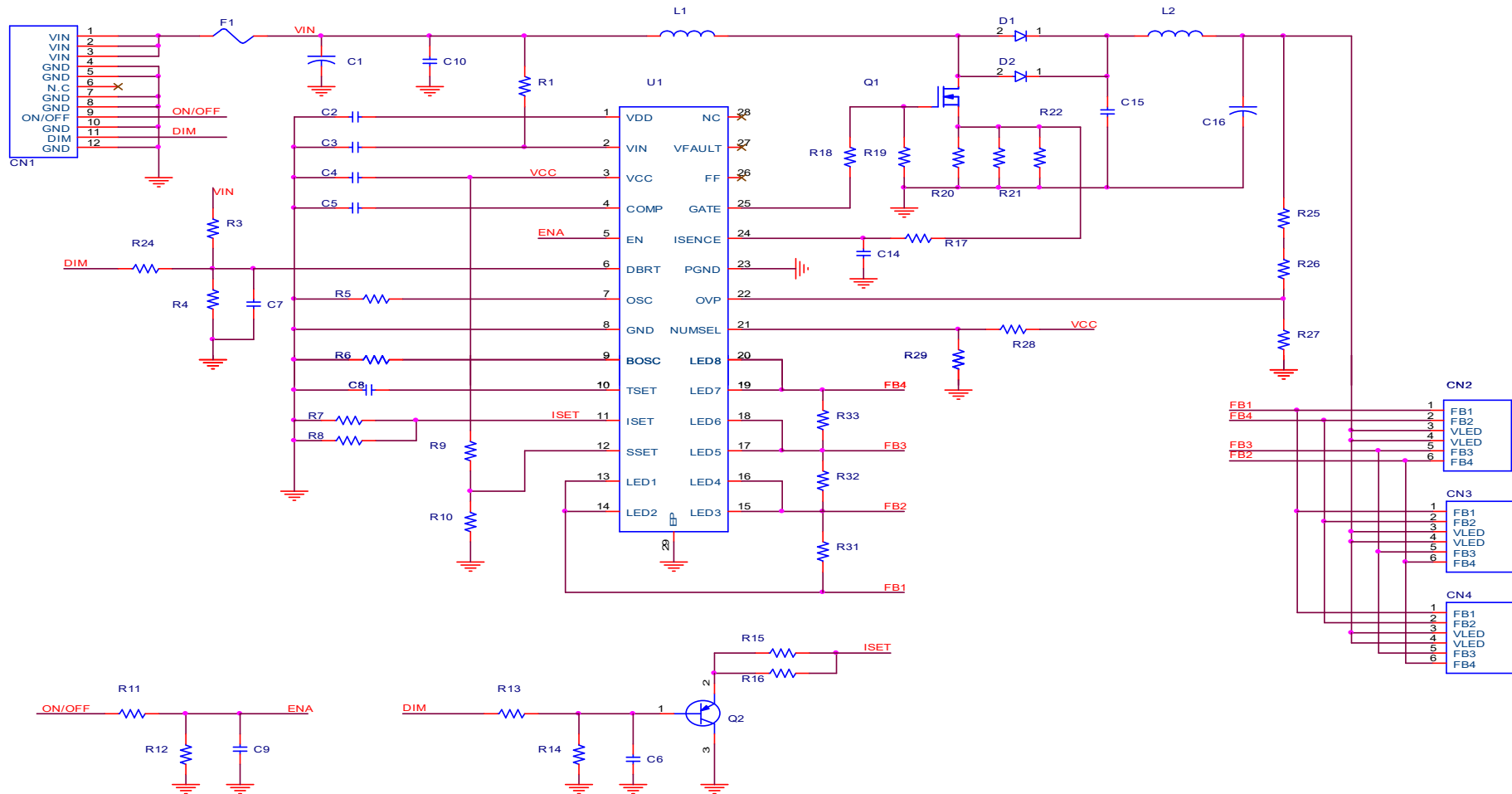

GREEN C&C TECH	LED DRIVER SPECIFICATION GH766A(A11)	Publishing Date Reforming Date	2024.07.22
---------------------------	---	-----------------------------------	------------

10. RELIABILITY TEST SPEC.

NO.	ITEM	Conditions and Method
1	High Temperature Storage Test	Temp : 80 °C Duration : 250hrs
2	Low Temperature Storage Test	Temp : -30 °C Duration : 250hrs
3	High Temperature High Humidity Operation Test	Temp : 70 °C Humidity : 95%RH Duration : 250hrs
4	Signal On/Off Test	Temp : Normal Temperature On-Off Signal On 10sec / Off 10sec Power on full Load 30,000 cycles
5	Thermal Shock Test	Temp : -30 °C ↔ 80 °C, 100 cycles (30min) (30min)
6	High Temperature Operation Test	Temp : 70 °C Duration : 250hrs
7	Low Temperature Operation Test	Temp : -20 °C Duration : 250hrs

GREEN C&C TECH	LED DRIVER SPECIFICATION GH766A(A11)	Publishing Date Reforming Date	2024.07.22
----------------	---	-----------------------------------	------------

11. FLOW CHART

MODEL (TYPE)	GH766A(A11)	REVISION	0
WRITER	K.S.LEE		
FLOW CHART	PROCESS	EQUIPMENTS	Remark
	Raw Material		PART LIST
	Solder Printing	Cream-solder Printer	
	Surface Mounting	Low-high Mounter	
	Reflow Soldering (CTQ)	Reflower	
	Visual Inspection (AOI)	Microscope, Vision-Master	
	Label attachment	Marking	
	Preparing Process		
	Soldering by Hand for Discrete Parts		
	Spreading Silicon	Silicon Dispenser	
	Insert Lead Parts		
	Wave-Soldering	Wave-Soldering Machine	
	Visual Inspection		
	PCB Division		
	Aging	Power Supply, Aging Box	2hrs
	Electrical Characteristics inspection	Testing System, Testing JIG	
	Insulator Attachment		
	Bar-Code Reading	Bar-Code Reader	
	Package		
	Outgoing Inspection	Testing System, Testing JIG	List of Inspection
	Shipping		
Based on Standard Rule	GCCT766AL		

GREEN C&C TECH	LED DRIVER SPECIFICATION GH766A(A11)	Publishing Date	2024.07.22
		Reforming Date	

12. PACKING

12.1. BOX

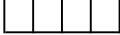
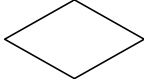
 <small>LEAD-FREE</small>			
1. Customer		<div style="border: 1px solid black; width: 100%; height: 15px; margin-bottom: 5px;"></div>	L/C NO : C/T NO : MADE IN KOREA
2. PART NAME	GH766A(A11)		
3. PO NO			
4. Q'ty	000 EA		
5. Date	00.00.00		
6. LOT NO			

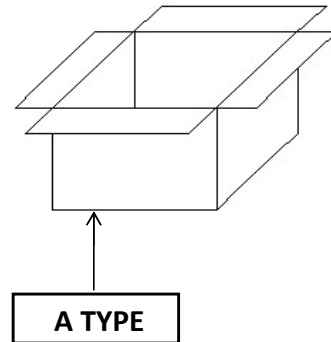

12.2. TRAY

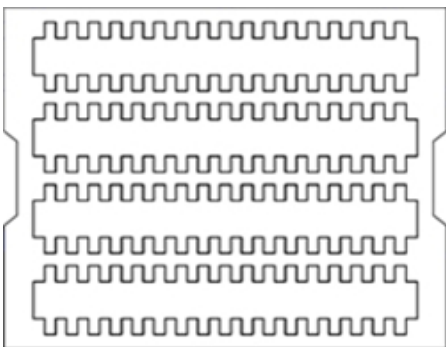

SYMBOL	TYPE NO
PACKING-TRAY	393*324*58
PACKING-BOX	415*340*332
PACKING-PAD	400*325*5

1 TRAY : 54EA (GR2054)
1BOX : 5 TRAY (270EA) - A TYPE

GREEN C&C TECH	LED DRIVER SPECIFICATION GH766A(A11)	Publishing Date Reforming Date	2024.07.22
----------------	---	-----------------------------------	------------

13. Material list for safety GH766A(A11)

SYMBOL	NAME	TYPE No	MANUFACTURER	DESCRIPTION
F1	FUSE	CCF1N4	KOA	UL FILE NO. : E171861
		451004	LITTELFUSE	UL FILE NO. : E10480
		453004		CSA FILE NO : LR29862
		CB61F4A	COOPER BUSSNANN	UL FILE NO. : E19180
PCB	Printed Writing Board	FR4	SEOKANG	UL FILE NO. : E150774
			DAUN ENG	UL FILE NO. : E529627
			AMC KOREA	UL FILE NO. : E475806
			SKY TECHNOLOGY	UL FILE NO. : E513927
CN1	Connector	12505WR-12A	YEONHO	UL FILE NO. : E108706
CN2		12507WR-06L	YEONHO	UL FILE NO. : E108706
CN3		10019HR-H06B	YEONHO	UL FILE NO. : E108706
CN4		05002HR-H06CE	YEONHO	UL FILE NO. : E108706