

Specification

G215HVN01.1(04)

21.5" - 1920x1080 – LVDS

Spec Revision: 1.0
Revision Date: 05.06.2024

Note: This specification is subject to change without prior notice



AUO Display+

Product Specification

G215HVN01.1

Preliminary Specification

Final Specification

Module	21.5" Color TFT-LCD
Model Name	G215HVN01.1

Company
<hr/>
Checked & Approved by
<hr/>
Date
<hr/>

Approved by	Date
<hr/>	<hr/>
Prepared by	
<hr/>	<hr/>
General Display Business Unit / AUO Display Plus Corporation	

Contents

1. Operating Precautions	4
2. General Description.....	5
2.1 Display Characteristics.....	5
2.2 Optical Characteristics	6
3. Functional Block Diagram.....	9
4. Absolute Maximum Ratings	10
4.1 Absolute Ratings of TFT LCD Module.....	10
4.2 Absolute Ratings of Environment	10
5. Electrical Characteristics	11
5.1 TFT LCD Module.....	11
6. Signal Characteristic	14
6.1 Pixel Format Image	14
6.2 Scanning Direction	14
6.3 Signal Description	15
6.4 The Input Data Format	16
6.5 Interface Timing.....	17
6.6 Power ON/OFF Sequence	18
7. Connector & Pin Assignment.....	19
7.1 TFT LCD Module: LVDS Connector	19
7.2 Backlight Unit: LED Connector.....	20
8. Reliability Test Criteria	21
9. Mechanical Characteristics.....	22
10. Label and Packaging	24
10.1 Shipping Label	24
10.2 Carton Package	25
11 Safety.....	26
11.1 Keen Edge Requirements	26
11.2 Materials.....	26
11.2.1 Toxicity.....	26
11.3 Capacitors	26
11.4 International Safety Standard Compliance	26



AUO Display+
Record of Revision

Version and Date	Page	Old description	New Description
V1.0 2024/05/06			First Edition

AUO Display Plus Confidential
For DATAMODUL Internal Use Only
20240909 16:13:12

AUO Display Plus Confidential
For DATAMODUL Internal Use Only
20240909 16:13:12

AUO Display Plus Confidential
For DATAMODUL Internal Use Only
20240909 16:13:12

AUO Display Plus Confidential
For DATAMODUL Internal Use Only
20240909 16:13:12

1. Operating Precautions

- 1) Since front polarizer is easily damaged, please be cautious and not to scratch it.
- 2) Be sure to turn off power supply when inserting or disconnecting from input connector.
- 3) Wipe off water drop immediately. Long contact with water may cause discoloration or spots.
- 4) When the panel surface is soiled, wipe it with absorbent cotton or soft cloth.
- 5) Since the panel is made of glass, it may be broken or cracked if dropped or bumped on hard surface.
- 6) Since CMOS LSI is used in this module, take care of static electricity and insure human earth when handling.
- 7) Do not open nor modify the module assembly.
- 8) Do not press the reflector sheet at the back of the module to any direction.
- 9) In case if a module has to be put back into the packing container slot after it was taken out from the container, do not press the center of the LED Reflector edge. Instead, press at the far ends of the LED Reflector edge softly. Otherwise the TFT Module may be damaged.
- 10) At the insertion or removal of the Signal Interface Connector, be sure not to rotate nor tilt the Interface Connector of the TFT Module.
- 11) TFT-LCD Module is not allowed to be twisted & bent even force is added on module in a very short time. Please design your display product well to avoid external force applying to module by end-user directly.
- 12) Small amount of materials without flammability grade are used in the TFT-LCD module. The TFT-LCD module should be supplied by power complied with requirements of Limited Power Source (IEC60950-1 or UL60950-1), or be applied exemption.
- 13) Severe temperature condition may result in different luminance, response time.
- 14) Continuous operating TFT-LCD Module under high temperature environment may accelerate LED light bar exhaustion and reduce luminance dramatically.
- 15) The data on this specification sheet is applicable when TFT-LCD module is placed in landscape position.
- 16) Continuous displaying fixed pattern may induce image sticking. It's recommended to use screen saver or moving content periodically if fixed pattern is displayed on the screen.

AUO Display+

2. General Description

This specification applies to the 21.5 inch-wide Color TFT-LCD Module G215HVN01.1. The display supports the Full HD - 1920(H) x 1080(V) screen format and 16.7M colors (RGB 8-bits data). All input signals are dual channel LVDS interface.

LED driver board is included. G215HVN01.1 is designed for industrial display applications.

2.1 Display Characteristics

The following items are characteristics summary on the table under 25 °C condition:

Items	Unit	Specifications
Screen Diagonal	[inch]	21.5
Active Area	[mm]	476.64 (H) x 268.11 (V)
Pixels H x V		1920(x3) x 1080
Pixel Pitch	[mm]	0.24825 x 0.24825
Pixel Arrangement		R.G.B. Vertical Stripe
Display Mode		VA Mode, Normally Black
Nominal Input Voltage (VDD)	[Volt]	+5.0 V
Typical Power Consumption	[Watt]	18.14 W (Cell 3.5W + LED 14.64W) (with LED driver board, all white pattern)
Weight	[Grams]	1,750 (± 175 g)
Physical Size	[mm]	495.6(W) x 292.2(H) x 11.7(D)
Electrical Interface		Dual channel LVDS
Surface Treatment		Anti-glare, Hardness 3H
Support Color		16.7M colors (RGB 8 bits)
Temperature Range		
Operating	[°C]	0~60 °C
Storage (Non-Operating)	[°C]	-20~60 °C
RoHS Compliance		RoHS Compliance
Light Bar Unit		LED, Non-Replaceable

2.2 Optical Characteristics

The optical characteristics are measured under stable conditions at 25°C.

Item	Unit	Conditions	Min.	Typ.	Max.	Note
White Luminance	[cd/m ²]	100% Dimming (center point)	200	250	-	1
Uniformity	%	9 Points	75	80	-	1, 2, 3
Contrast Ratio			3000	5000	-	4
Cross talk	%		-	-	1.5	5
Response Time	[msec]	Rising	-	20	25	6
	[msec]	Falling	-	5	10	
	[msec]	Raising + Falling	-	25	35	
Viewing Angle	[degree]	Horizontal (Right) CR = 10 (Left)	75	89	-	7
	[degree]		75	89	-	
	[degree]	Vertical (Upper) CR = 10 (Lower)	75	89	-	
	[degree]		75	89	-	
Color / Chromaticity Coordinates (CIE 1931)		Red x	0.609	0.639	0.669	
		Red y	0.303	0.333	0.363	
		Green x	0.290	0.320	0.350	
		Green y	0.593	0.623	0.653	
		Blue x	0.125	0.155	0.185	
		Blue y	0.018	0.048	0.078	
		White x	0.283	0.313	0.343	
		White y	0.299	0.329	0.359	
Color Gamut	%		-	72		

Note 1: Measurement method

Equipment Pattern Generator, Power Supply, Digital Voltmeter, Luminance meter (SR_3 or equivalent)

Aperture 1° with 50cm viewing distance

Test Point Center

Environment < 1 lux

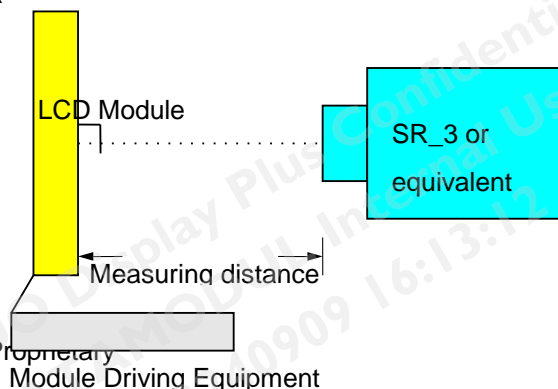

Note 2: Definition of 9 points position (Display active area : 304.128(H) x 228.096(V))

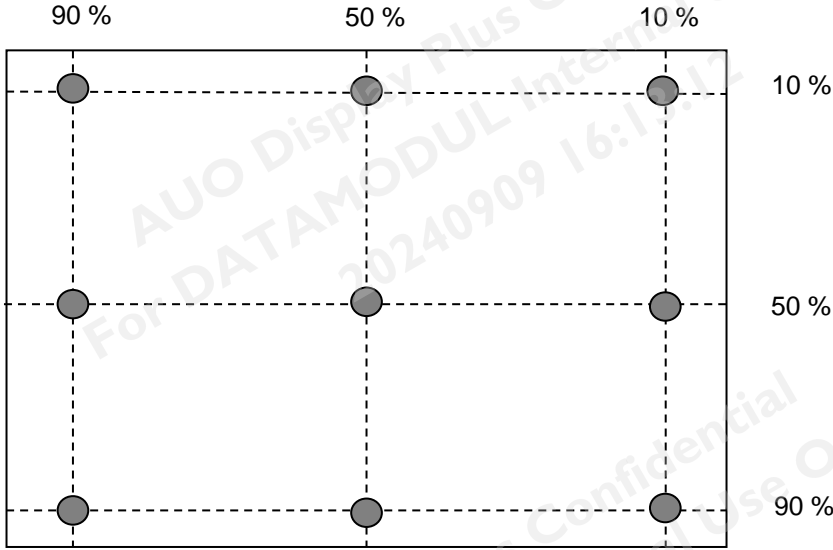

Note 3: The luminance uniformity of 9 points is defined by dividing the minimum luminance values by the maximum test point luminance

$$\delta_{w9} = \frac{\text{Minimum Brightness of nine points}}{\text{Maximum Brightness of nine points}}$$

Note 4 : Definition of contrast ratio (CR):

$$\text{Contrast ratio (CR)} = \frac{\text{Brightness on the "White" state}}{\text{Brightness on the "Black" state}}$$

Note 5 : Definition of cross talk (CT)

$$CT = | YB - YA | / YA \times 100 (\%)$$

Where

YA = Luminance of measured location without gray level 0 pattern (cd/m2)

YB = Luminance of measured location with gray level 0 pattern (cd/m2)

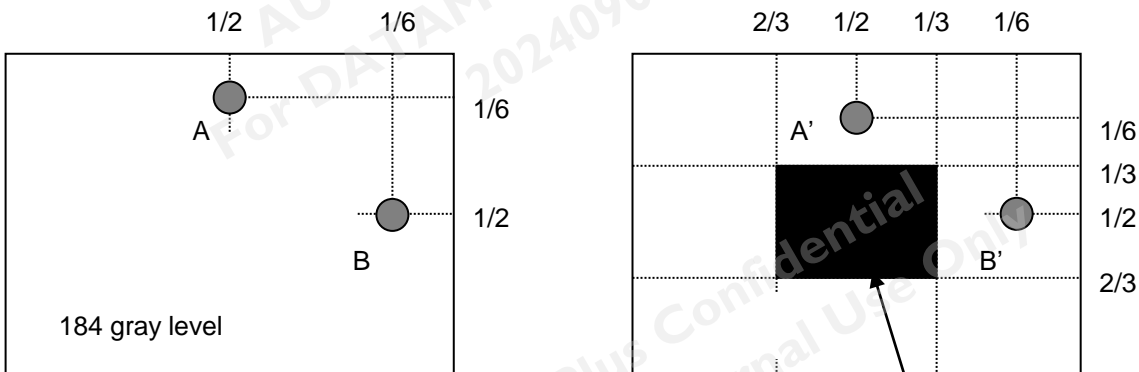

AUO Display+

Note 6: Definition of response time:

The output signals of photo detector are measured when the input signals are changed from “White” to “Black” (falling time) and from “Black” to “White” (rising time), respectively. The response time interval is between 10% and 90% of amplitudes. Please refer to the figure as below.

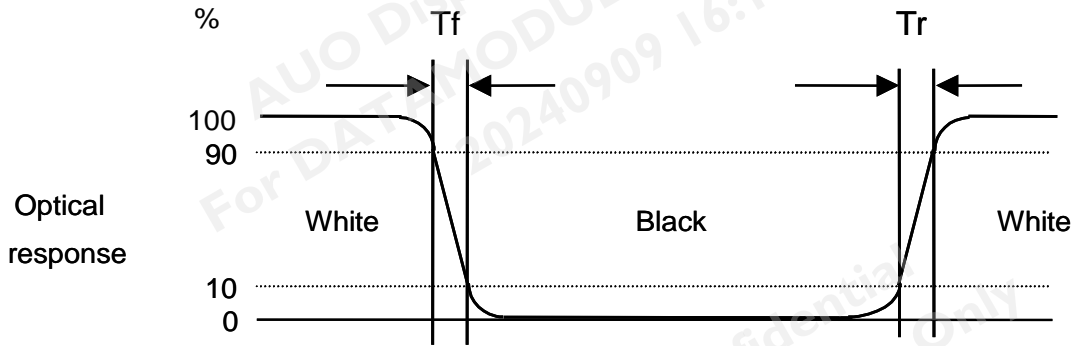

Note 7: Definition of viewing angle

Viewing angle is the measurement of contrast ratio ≥ 10 , at the screen center, over a 180° horizontal and 180° vertical range (off-normal viewing angles). The 180° viewing angle range is broken down as below: 90° (θ) horizontal left and right, and 90° (Φ) vertical high (up) and low (down). The measurement direction is typically perpendicular to the display surface with the screen rotated to its center to develop the desired measurement viewing angle.

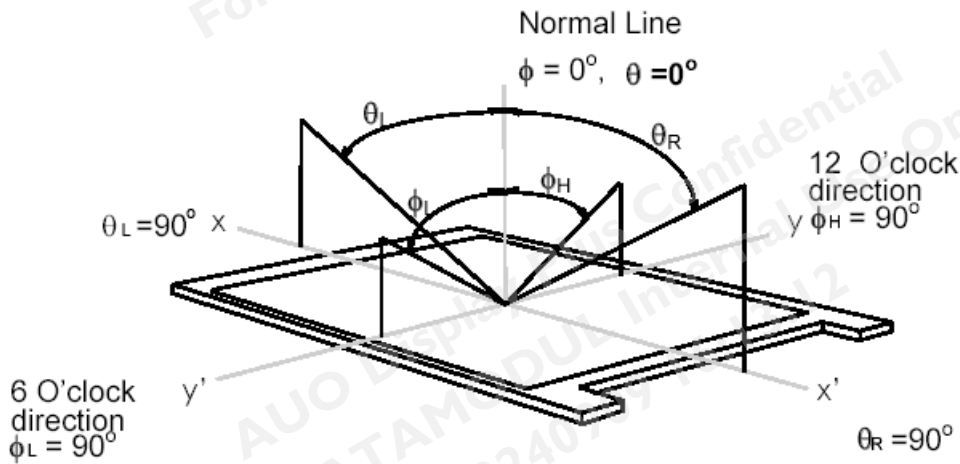

AUO Display+

3. Functional Block Diagram

The following diagram shows the functional block of this model.

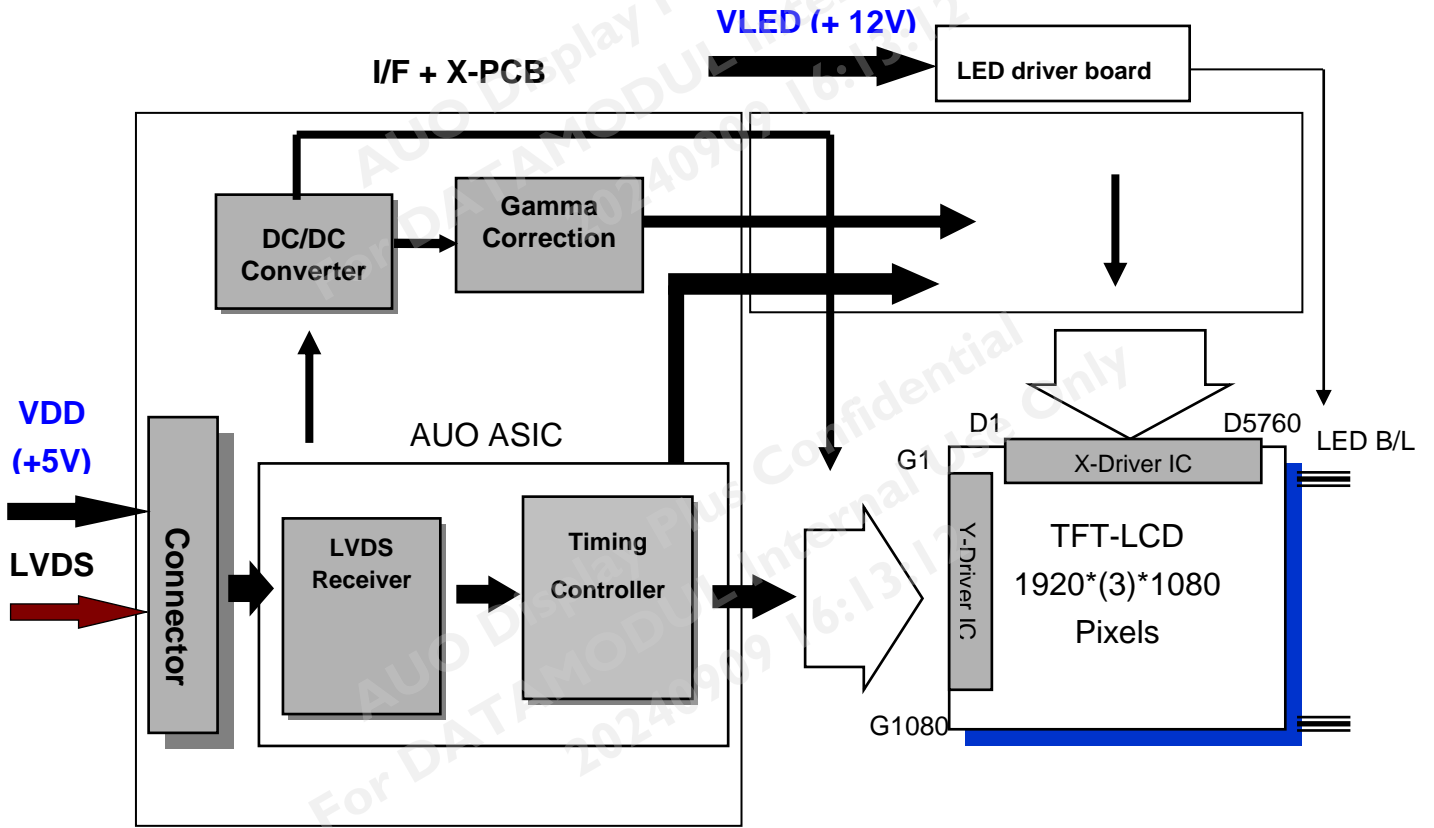

AUO Display+

4. Absolute Maximum Ratings

4.1 Absolute Ratings of TFT LCD Module

Item	Symbol	Min	Max	Unit
Logic/LCD Drive	VDD	0	5.5	[Volt]

4.2 Absolute Ratings of Environment

Item	Symbol	Min	Max	Unit
Operating	TOP	0	60	[°C]
Operation Humidity	HOP	5	90	[%RH]
Storage	TST	-20	60	[°C]
Storage Humidity	HST	5	90	[%RH]

Note: Maximum Wet-Bulb should be 39°C and no condensation.

AUO Display+

5. Electrical Characteristics

5.1 TFT LCD Module

5.1.1 Power Specification

Symbol	Parameter	Min	Typ	Max	Unit	Remark
VDD	Logic/LCD Drive Voltage	4.5	5.0	5.5	[Volt]	± 10%
IDD	VDD Current	-	0.7	0.8	[A]	All White Pattern (VDD=5 V, at 60Hz)
Irush	LCD Inrush Current	-	-	3	[A]	Note 1
PDD	VDD Power	-	3.5	4.4	[Watt]	All White Pattern (VDD=5 V, at 60Hz)

Note 1: Measurement condition:

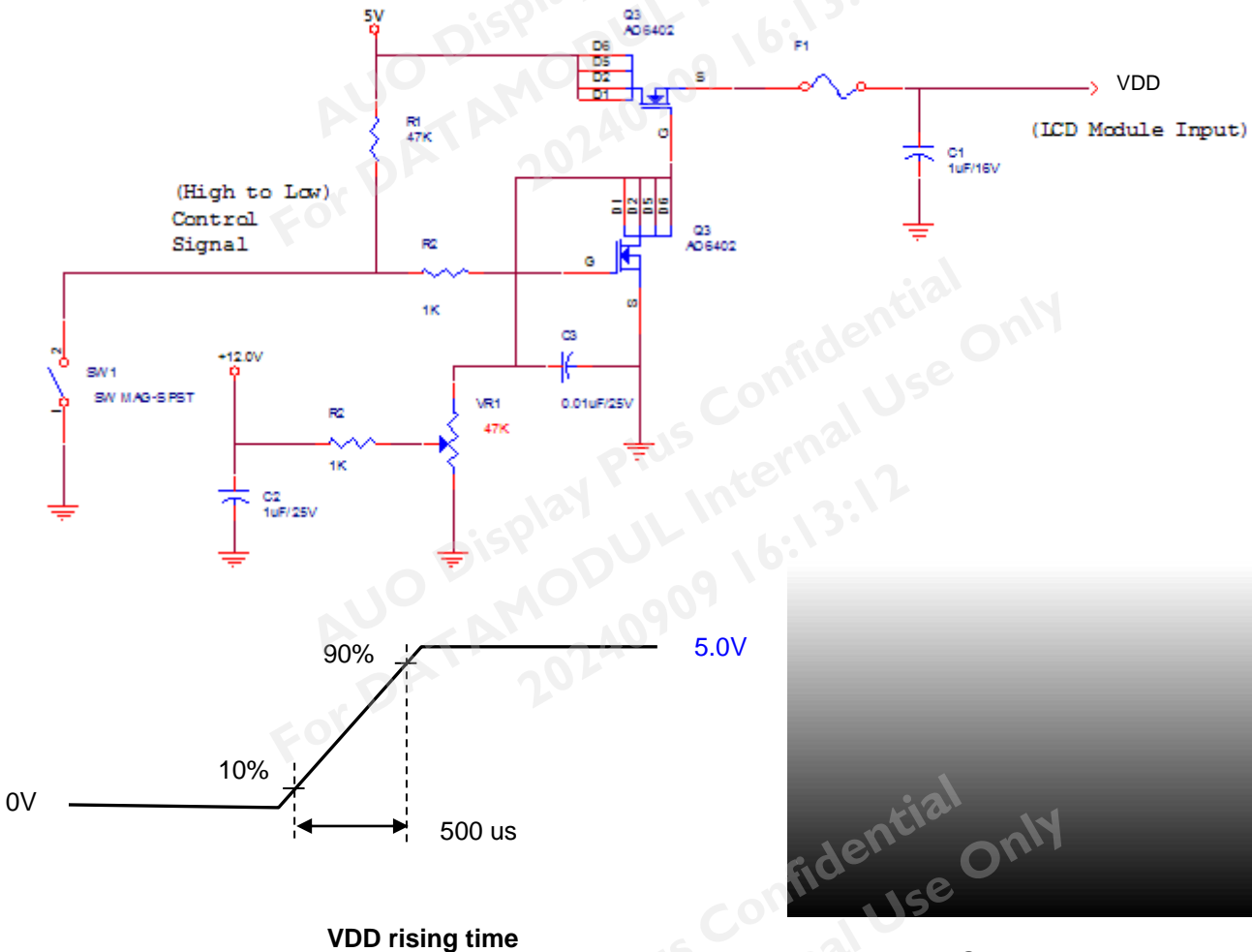

64 Gray pattern

AUO Display+

5.1.2 Signal Electrical Characteristics

Input signals shall be low or Hi-Z state when VDD is off.

Symbol	Item	Min.	Typ.	Max.	Unit	Remark
VTH	Differential Input High Threshold	-	-	+100	[mV]	VCM=1.2V
VTL	Differential Input Low Threshold	-100	-	-	[mV]	VCM=1.2V
VID	Input Differential Voltage	100	-	600	[mV]	
VICM	Differential Input Common Mode Voltage	+1.0	+1.2	+1.5	[V]	VTH/VTL= ±100mV

Note: LVDS Signal Waveform.

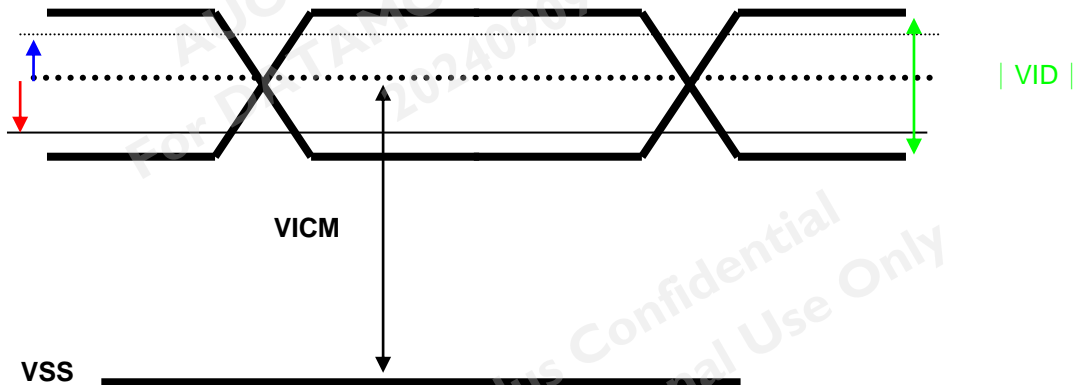

AUO Display+

5.2 Backlight Unit

5.2.1 Parameter guideline for LED

Following characteristics are measured under stable condition using a LED driving board at 25°C .

Symbol	Parameter	Min	Typ	Max	Unit	Remark
VLED	Input Voltage	10.8	12	13.2	Volt	
ILED	Input Current	-	1.22	-	A	100% Dimming
PLED	Power Consumption	-	14.64	16.10	Wat	100% Dimming
Irush	Inrush Current	-	-	3	A	
Backlight on/off	On Control Voltage	3	-	5.5	Volt	
	Off Control Voltage	0	-	0.8	Volt	
Backlight Dimming (PWM dimming)	PWM Dimming	-	0.2	20	KHz	
	High Voltage	4.5	5	5.5	Volt	
	Low Voltage	0	-	0.8	Volt	
	Dimming Duty Cycle	5	-	100	%	
I _F	LED Forward Current	-	60	-	mA	Ta = 25°C
Operating		30000	-	-	Hrs	Ta = 25°C

Note 1: Ta means ambient temperature of TFT-LCD module.

Note 2: If TFT-LCD module is driven at high ambient temperature & humidity condition. The operating life will be reduced.

Note 3: Operating life means brightness goes down to 50% initial brightness. Min. operating life time is estimated data.

Note 4: LED light bar structure: (5 strings x 14pcs / string =70 pcs LED)

AUO Display+

6. Signal Characteristic

6.1 Pixel Format Image

Following figure shows the relationship between input signal and LCD pixel format.

	1			2			...						1919			1920		
1st Line	R	G	B	R	G	B						R	G	B	R	G	B

1080 Line	R	G	B	R	G	B						R	G	B	R	G	B

6.2 Scanning Direction

The following figures show the image seen from the front view. The arrow indicates the direction of scan.

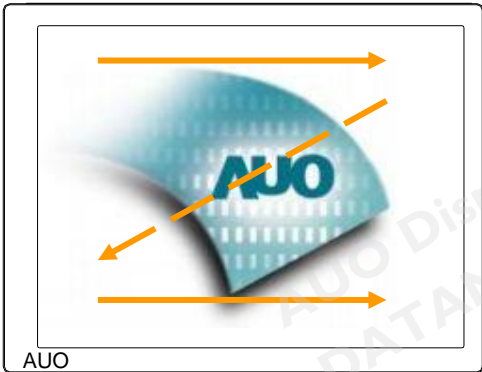

6.3 Signal Description

The module using a pair of LVDS receiver SN75LVDS82(Texas Instruments) or compatible. LVDS is a differential signal technology for LCD interface and high speed data transfer device. Transmitter shall be SN75LVDS83(negative edge sampling) or compatible. The first LVDS port(RxOxxx) transmits odd pixels while the second LVDS port(RxExxx) transmits even pixels.

Pin#	Signal Name	Description
1	RXinO0-	Negative LVDS differential data input (Odd data)
2	RXinO0+	Positive LVDS differential data input (Odd data)
3	RXinO1-	Negative LVDS differential data input (Odd data)
4	RXinO1+	Positive LVDS differential data input (Odd data)
5	RXinO2-	Negative LVDS differential data input (Odd data, H-Sync, V-Sync, DSPTMG)
6	RXinO2+	Positive LVDS differential data input (Odd data, H-Sync, V-Sync, DSPTMG)
7	GND	Power Ground
8	RxOCLKIN-	Negative LVDS differential clock input (Odd clock)
9	RxOCLKIN+	Positive LVDS differential clock input (Odd clock)
10	RXinO3-	Negative LVDS differential data input (Odd data)
11	RXinO3+	Positive LVDS differential data input (Odd data)
12	RXinE0-	Negative LVDS differential data input (Even data)
13	RXinE0+	Positive LVDS differential data input (Even data)
14	GND	Power Ground
15	RXinE1-	Negative LVDS differential data input (Even data)
16	RXinE1+	Positive LVDS differential data input (Even data)
17	GND	Power Ground
18	RXinE2-	Negative LVDS differential data input (Even data)
19	RXinE2+	Positive LVDS differential data input (Even data)
20	RxECLKIN-	Negative LVDS differential clock input (Even clock)
21	RxECLKIN+	Positive LVDS differential clock input (Even clock)
22	RXinE3-	Negative LVDS differential data input (Even data)
23	RXinE3+	Positive LVDS differential data input (Even data)
24	GND	Power Ground
25	NC	No connection (for AUO test only. Do not connect)
26	NC	No connection (for AUO test only. Do not connect)
27	NC	No connection (for AUO test only. Do not connect)
28	VDD	Power +5V
29	VDD	Power +5V
30	VDD	Power +5V

6.4 The Input Data Format

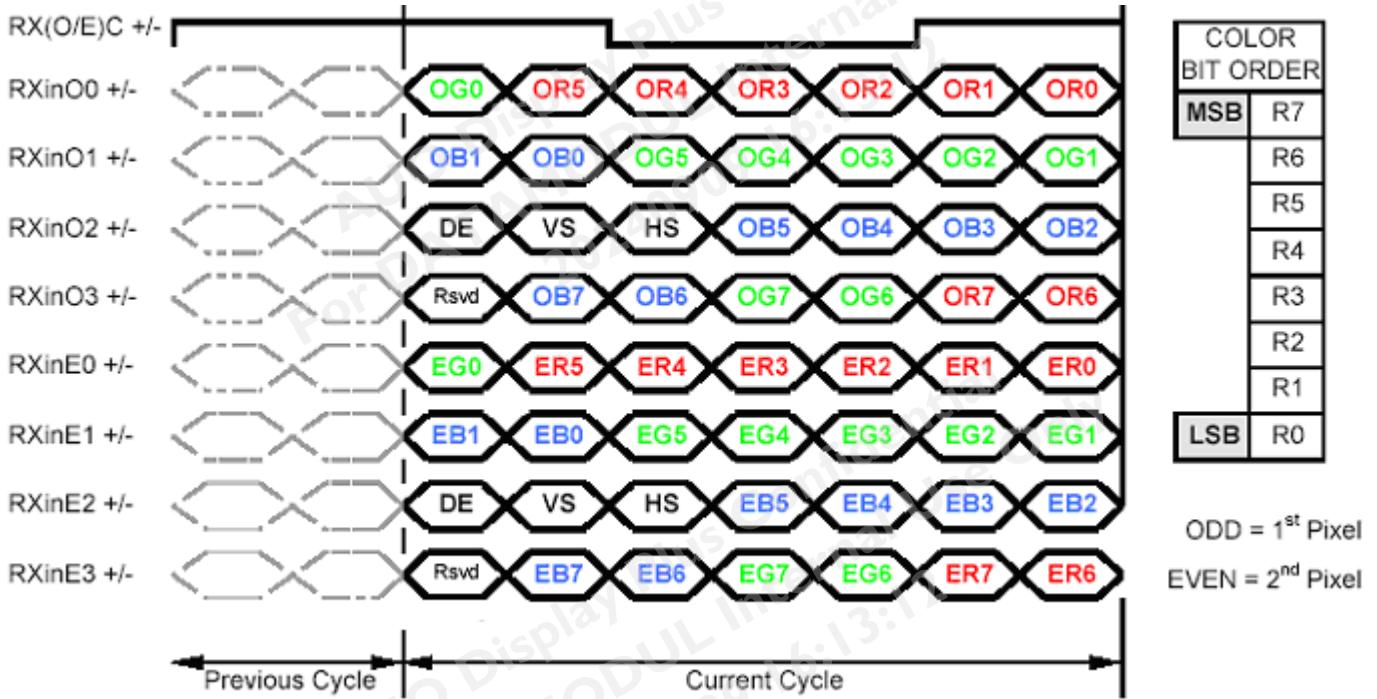

6.5 Interface Timing

6.5.1 Timing Characteristics

Signal	Parameter	Symbol	Min.	Typ.	Max.	Unit	
Clock Timing	Clock frequency	$1/T_{Clock}$	40	72	83	MHz	
Vsync Timing	Vertical Section	Period	T_V	1092	1130	1653	T_{Line}
		Active	T_{VD}	1080	1080	1080	
		Blanking	T_{VB}	12	50	573	
Hsync Timing	Horizontal Section	Period	T_H	1004	1050	1100	T_{Clock}
		Active	T_{HD}	960	960	960	
		Blanking	T_{HB}	44	90	140	
Frame Rate		F	50	60	75	Hz	

Note: DE mode only.

Note : Typical value refer to VESA STANDARD

6.5.2 Input Timing Diagram

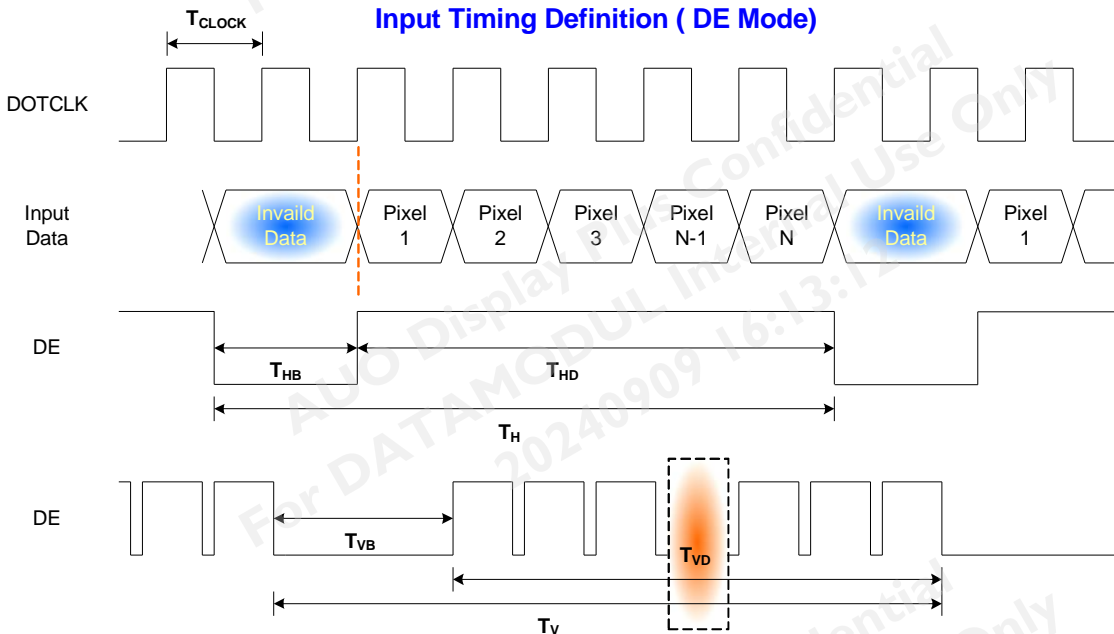

AUO Display+

6.6 Power ON/OFF Sequence

VDD power and LED on/off sequence is as below. Interface signals are also shown in the chart. Signals from any system shall be Hi-Z state or low level when VDD is off.

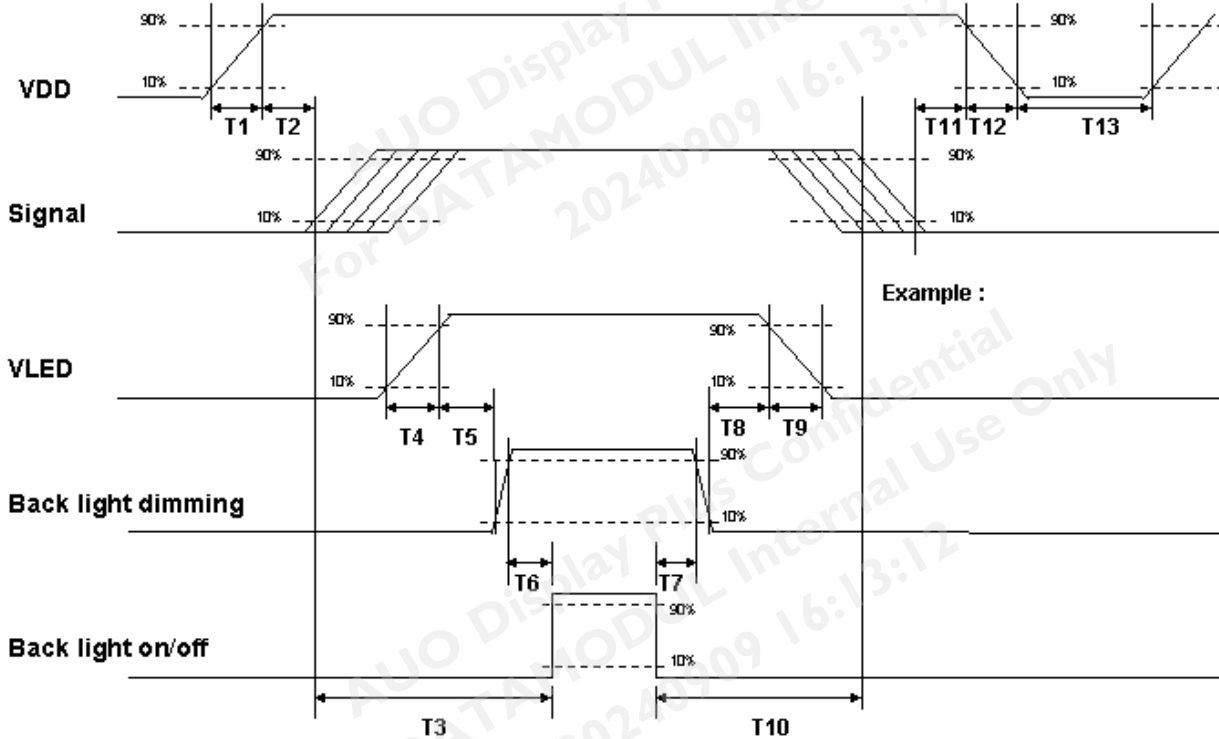

Power ON/OFF sequence timing

Parameter	Value			Units
	Min.	Typ.	Max.	
T1	0.5	--	10	[ms]
T2	30	40	50	[ms]
T3	200	--	--	[ms]
T4	0.5	--	10	[ms]
T5	10	--	--	[ms]
T6	10	--	--	[ms]
T7	0	--	--	[ms]
T8	10	--	--	[ms]
T9	--	--	10	[ms]
T10	110	--	--	[ms]
T11	0	16	50	[ms]
T12	--	--	10	[ms]
T13	1000	--	--	[ms]

The above on/off sequence should be applied to avoid abnormal function in the display. Please make sure to turn off the power when you plug the cable into the input connector or pull the cable out of the connector.

7. Connector & Pin Assignment

Physical interface is described as for the connector on module. These connectors are capable of accommodating the following signals and will be following components.

7.1 TFT LCD Module: LVDS Connector

Connector Name / Designation	Signal Connector
Manufacturer	P-TWO
Connector Model Number	AL230F-A0G1D-P
Mating Housing Part Number	FI-X30HL (JAE) or compatible

Pin#	Signal Name	Pin#	Signal Name
1	RXinO0-	16	RXinE1+
2	RXinO0+	17	GND
3	RXinO1-	18	RXinE2-
4	RXinO1+	19	RXinE2+
5	RXinO2-	20	RxECLKIN-
6	RXinO2+	21	RxECLKIN+
7	GND	22	RXinE3-
8	RxOCLKIN-	23	RXinE3+
9	RxOCLKIN+	24	GND
10	RXinO3-	25	NC
11	RXinO3+	26	NC
12	RXinE0-	27	NC
13	RXinE0+	28	VDD
14	GND	29	VDD
15	RXinE1-	30	VDD

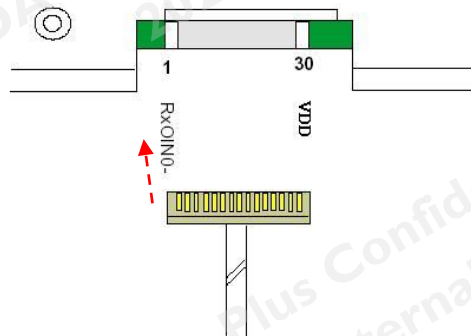

7.2 Backlight Unit: LED Connector

Connector Name / Designation	LED Connector
Manufacturer	E&T
Connector Model Number	3806K-F08N-03L or equivalent
Mating Model Number	H208K-P08N-02B or compatible

PIN #	SIGNAL NAME	DESCRIPTION
1	VLED	12V
2	VLED	12V
3	VLED	12V
4	GND	0V
5	GND	0V
6	GND	0V
7	Backlight on/off	5V On / 0V Off
8	Backlight dimming	5V Swing Voltage

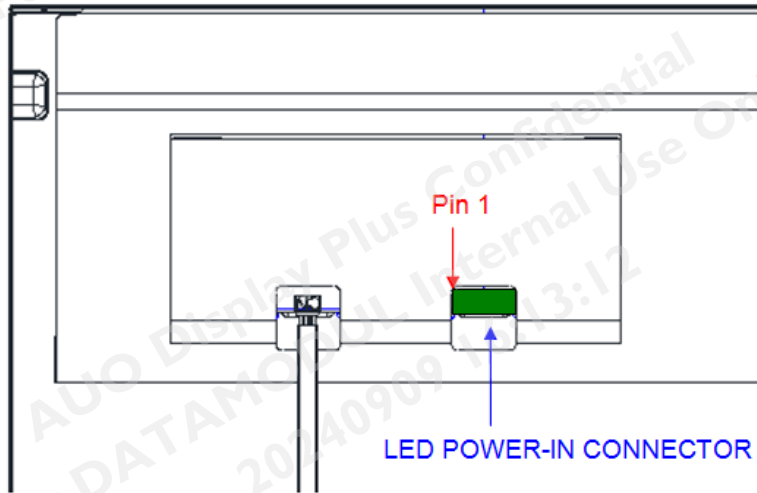

8. Reliability Test Criteria

Items	Required Condition	Note
Temperature Humidity Bias	50°C/80%,300 hours	
High Temperature Operation	60°C,300 hours	
Low Temperature Operation	0°C,300 hours	
Hot Storage	60°C,300 hours	
Cold Storage	-20°C,300 hours	
Thermal Shock Test	-20°C/30 min ,60°C/30 min ,100cycles	
Shock Test (Non-Operating)	50G,20ms,Half-sine wave,(±X, ±Y, ±Z)	
Vibration Test (Non-Operating)	1.5G, (10~200Hz, P-P) 30 mins/axis (X, Y, Z)	
On/off test	On/10 sec, Off/10 sec, 30,000 cycles	
ESD	Contact Discharge: ± 8KV, 150pF(330Ω) 1sec, 8 points, 25 times/ point Air Discharge: ± 15KV, 150pF(330Ω) 1sec, 8 points, 25 times/ point	Note 1

Note 1: According to EN61000-4-2, ESD class B: Some performance degradation allowed. No data lost. Self-recoverable. No hardware failures.

Note 2:

- Water condensation is not allowed for each test items.
- Each test is done by new TFT-LCD module. Don't use the same TFT-LCD module repeatedly for reliability test.
- The reliability test is performed only to examine the TFT-LCD module capability.
- To inspect TFT-LCD module after reliability test, please store it at room temperature and room humidity for 24 hours at least in advance.
- No function failure occurs.

9. Mechanical Characteristics

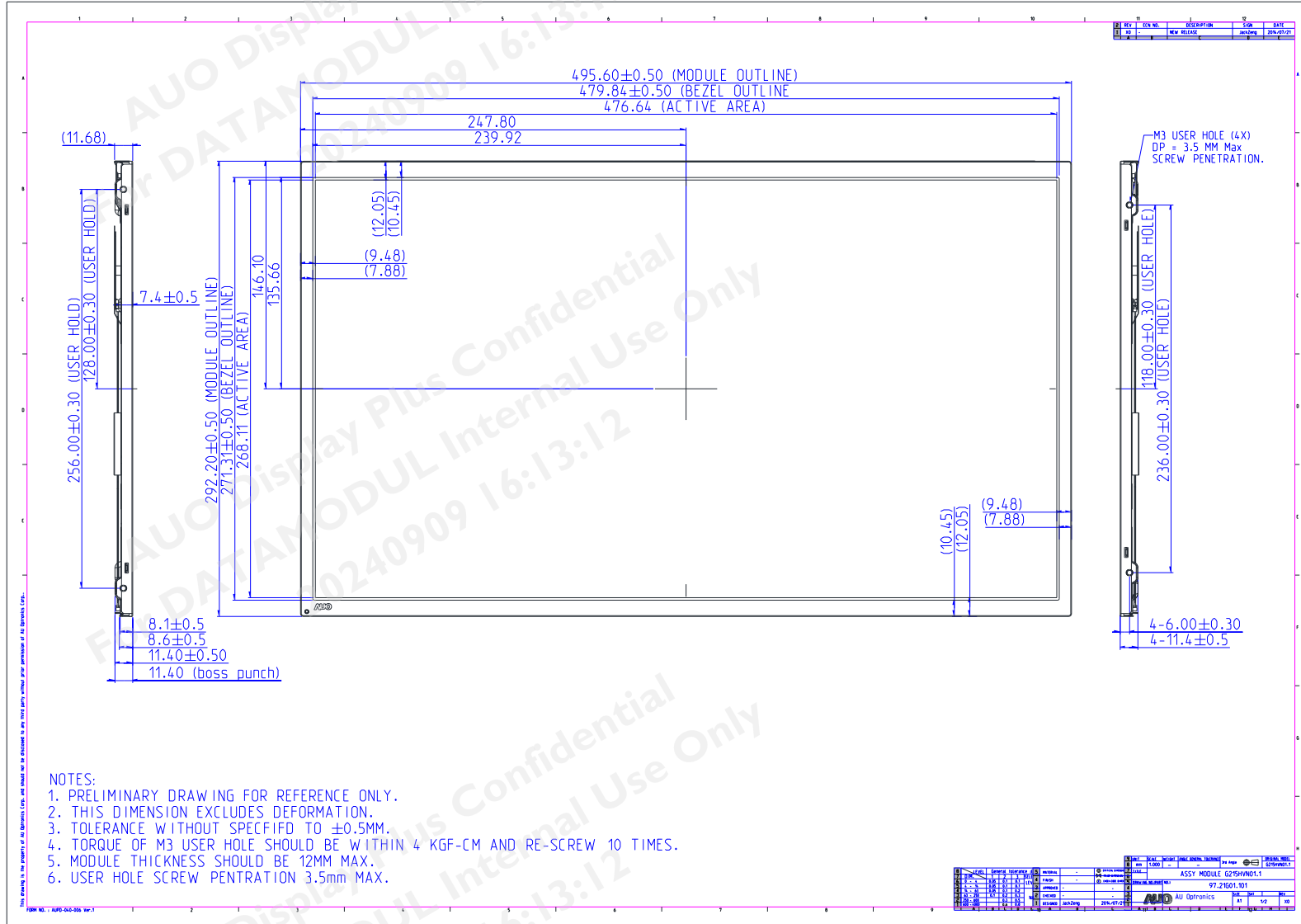



AUO Display+

Product Specification

G215HVN01.1

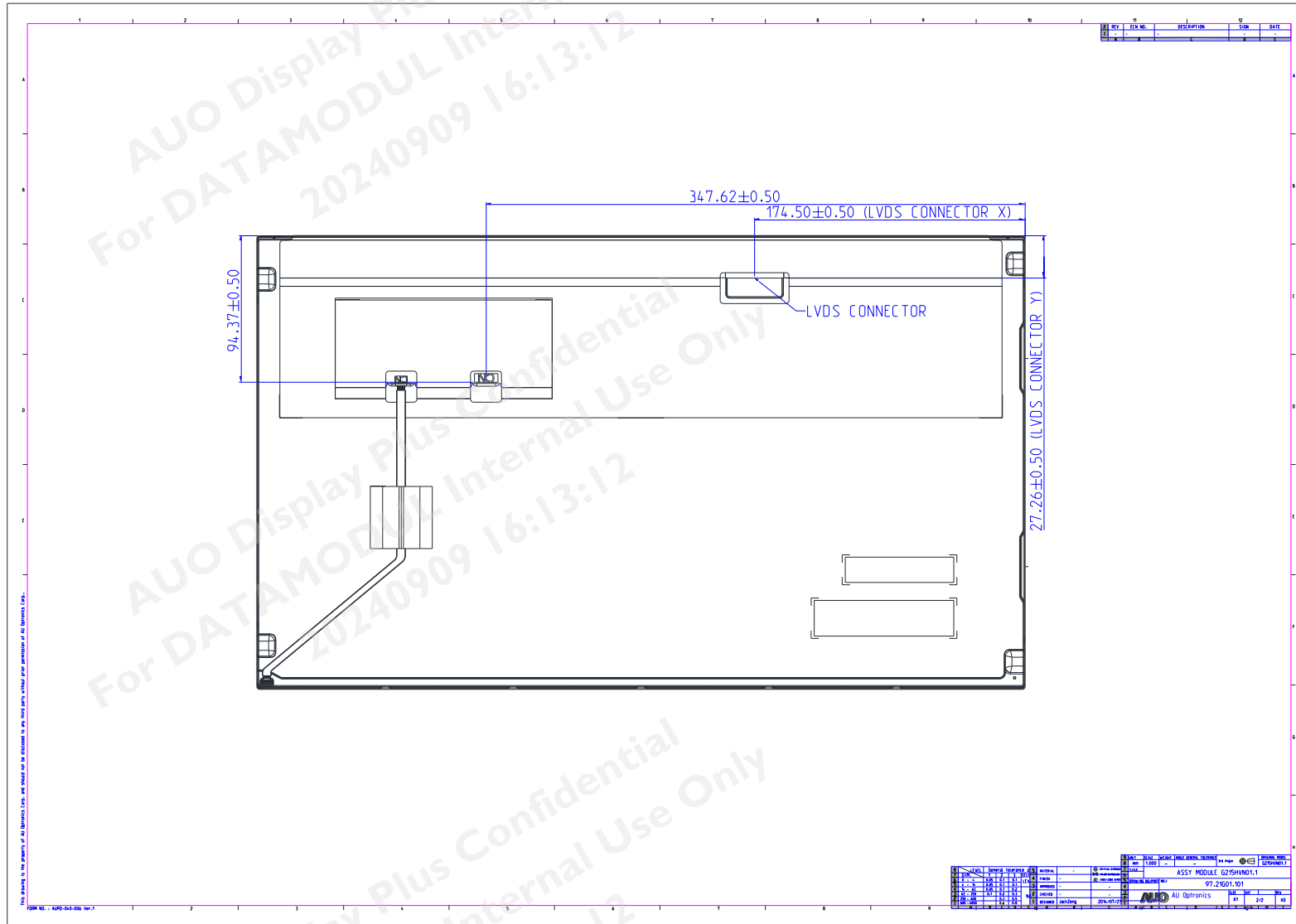

G215HVN01.1. ver. 1.0

AUO Display+

10. Label and Packaging

10.1 Shipping Label

The label is on the panel as shown below:

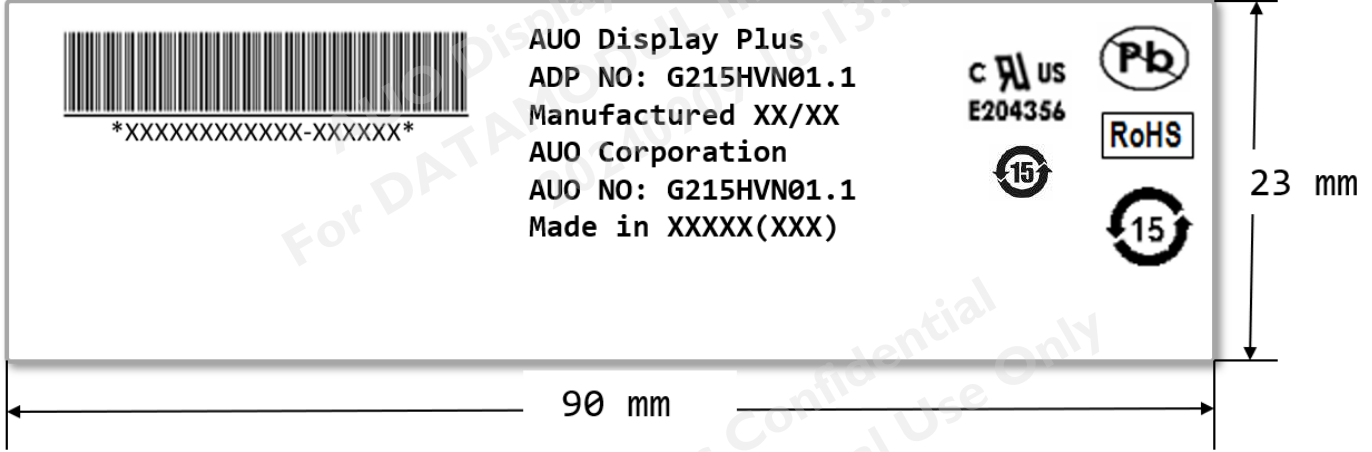

Note 1: For Pb Free products, AUO will add for identification.

Note 2: For RoHS compatible products, AUO will add for identification.

Note 3: For China RoHS compatible products, AUO will add for identification.

Note 4: The Green Mark will be presented only when the green documents have been ready by AUO Internal Green Team.

AUO Display+
10.2 Carton Package

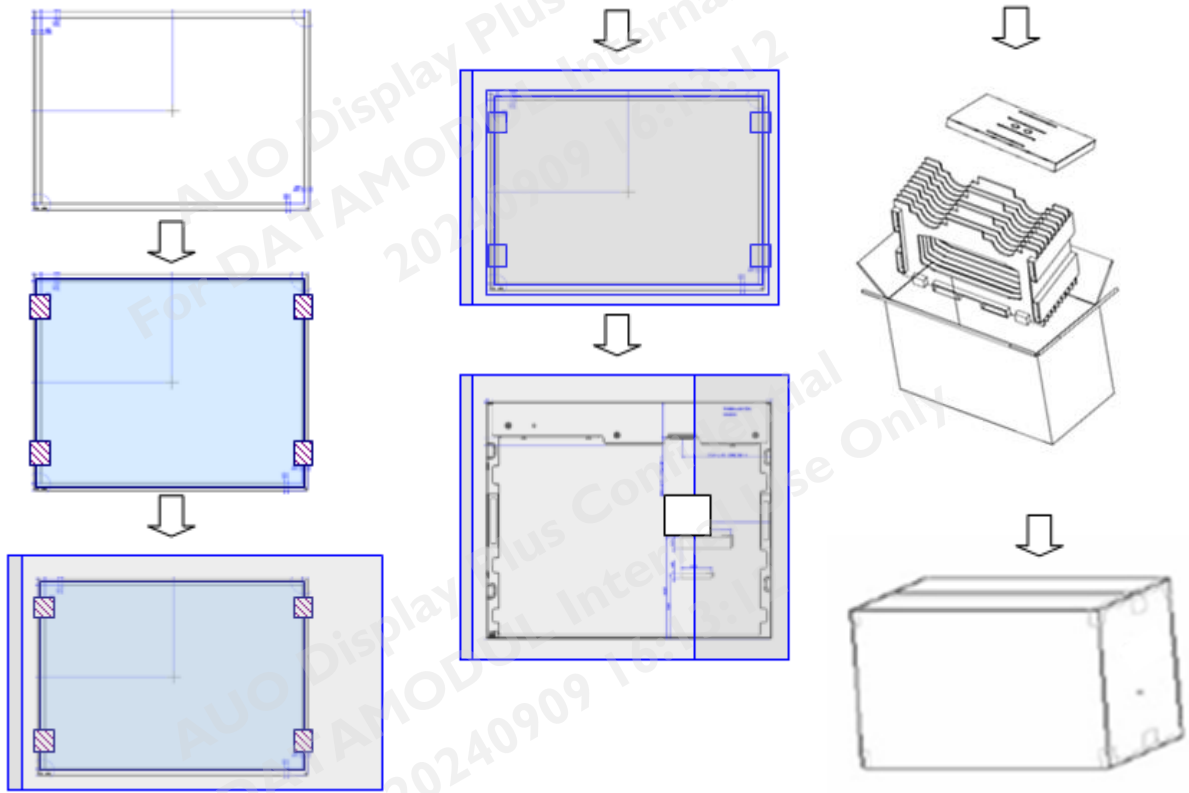

Max capacity : 9 TFT-LCD module per carton
 Max weight: 22.73(TBD) kg per carton
 Outside dimension of carton: 570mm(L)* 275mm(W)*395mm(H)
 Pallet size : 1150 mm * 840 mm * 132mm



AUO Display+

11 Safety

11.1 Keen Edge Requirements

There will be no sharp edges or comers on the display assembly that could cause injury.

11.2 Materials

11.2.1 Toxicity

There will be no carcinogenic materials used anywhere in the display module. If toxic materials are used, they will be reviewed and approved by the responsible AUO toxicologist.

11.2.2 Flammability

The printed circuit board will be made from material rated 94-V1 or better. The actual UL flammability rating will be printed on the printed circuit board.

11.3 Capacitors

If any polarized capacitors are used in the display assembly, provisions will be made to keep them from being inserted backwards.

11.4 International Safety Standard Compliance

The TFT-LCD module will satisfy all requirements for compliance to: IEC/UL 62368-1

DATA MODUL

Passion Displayed

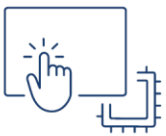

All good things come in threes:

With **Hardware**, **Software** and **Services**, we realise unique display solutions that turn your ideas into reality.

www.data-modul.com

