

Specification

G240HVN01.0

24" - 1920x1080 – LVDS

Spec Revision: 1.0
Revision Date: 10.12.2024

Note: This specification is subject to change without prior notice



AUO Display+

Product Specification

AUO-General
G240HVN01.0

Preliminary Specification

Final Specification

Module	24.0" Color TFT-LCD
Model Name	G240HVN01.0

Company	
<hr/>	
Checked & Approved by	Date
<hr/>	<hr/>

Approved by	Date
<hr/> Elsie Kuo	<hr/> 2024/12/10
Prepared by	
<hr/> Felix Lee	<hr/> 2024/12/10
General Display Business Unit / AUO Display Plus Corporation	

Contents

1. Operating Precautions	6
2. General Description	7
2.1 Display Characteristics	7
2.2 Optical Characteristics.....	8
3. Functional Block Diagram	11
4. Absolute Maximum Ratings	12
4.1 TFT LCD Module	12
4.2 Backlight Unit	12
4.3 Absolute Ratings of Environment	12
5. Electrical Characteristics.....	13
5.1 TFT LCD Module	13
5.2 Backlight Unit	15
6. Signal Characteristic	16
6.1 Pixel Format Image	16
6.2 Signal Description	17
6.3 The Input Data Format	18
6.4 Interface Timing.....	19
6.5 Power ON/OFF Sequence.....	20
7. Connector & Pin Assignment.....	21
7.1 TFT LCD Module: LVDS Connector	21
7.2 Backlight Unit: LED Connector	22
8. Reliability Test	23
9. Mechanical Characteristics	24
10. Label and Packaging	26
10.1 Shipping Label (on the rear side of TFT-LCD display).....	26
10.2 Carton Package.....	26
11. Safety	27
11.1 Sharp Edge Requirements	27
11.2 Materials	27
11.3 Capacitors	27
11.4 National Test Lab Requirement.....	27

Record of Revision

Version and Date	Page	Old description	New Description	Remark																																																																																																																																																																																																																																																												
0.1 2023/05/02	All	First Edition for Customer	All																																																																																																																																																																																																																																																													
0.2 2023/07/18	6	<p>2.2 Optical Characteristics¹⁾ The optical characteristics are measured under stable conditions at 25°C (Room Temperature).²⁾</p> <table border="1"> <thead> <tr> <th>Item</th> <th>Unit</th> <th>Conditions</th> <th>Min.</th> <th>Typ.</th> <th>Max.</th> <th>Note</th> </tr> </thead> <tbody> <tr> <td>White Luminance</td> <td>[cd/m²]</td> <td>I₀ = 90 mA</td> <td>1200</td> <td>1500</td> <td>∞</td> <td>1)</td> </tr> </tbody> </table>	Item	Unit	Conditions	Min.	Typ.	Max.	Note	White Luminance	[cd/m ²]	I ₀ = 90 mA	1200	1500	∞	1)	<p>2.2 Optical Characteristics¹⁾ The optical characteristics are measured under stable conditions at 25°C (Room Temperature).²⁾</p> <table border="1"> <thead> <tr> <th>Item</th> <th>Unit</th> <th>Conditions</th> <th>Min.</th> <th>Typ.</th> <th>Max.</th> <th>Note</th> </tr> </thead> <tbody> <tr> <td>White Luminance</td> <td>[cd/m²]</td> <td>I₀ = 91 mA</td> <td>1200</td> <td>1500</td> <td>∞</td> <td>1)</td> </tr> </tbody> </table>	Item	Unit	Conditions	Min.	Typ.	Max.	Note	White Luminance	[cd/m ²]	I ₀ = 91 mA	1200	1500	∞	1)																																																																																																																																																																																																																																	
Item	Unit	Conditions	Min.	Typ.	Max.	Note																																																																																																																																																																																																																																																										
White Luminance	[cd/m ²]	I ₀ = 90 mA	1200	1500	∞	1)																																																																																																																																																																																																																																																										
Item	Unit	Conditions	Min.	Typ.	Max.	Note																																																																																																																																																																																																																																																										
White Luminance	[cd/m ²]	I ₀ = 91 mA	1200	1500	∞	1)																																																																																																																																																																																																																																																										
	13	<p>5.2 Backlight Unit *5.2.1 LED Driver Following characteristics are measured under stable condition at 25°C (Room Temperature).¹⁾</p> <table border="1"> <thead> <tr> <th>Symbol</th> <th>Parameter</th> <th>Min.</th> <th>Typ.</th> <th>Max.</th> <th>Units</th> <th>Remark</th> </tr> </thead> <tbody> <tr> <td>V_{CC}</td> <td>Input Voltage</td> <td>∞</td> <td>∞</td> <td>∞</td> <td>Volt</td> <td>∞</td> </tr> <tr> <td>I_{IN}</td> <td>Input Current</td> <td>∞</td> <td>2.3</td> <td>∞</td> <td>A</td> <td>100% Dimming</td> </tr> <tr> <td>P_{LED}</td> <td>Power Consumption</td> <td>∞</td> <td>55.2</td> <td>∞</td> <td>Watt</td> <td>100% Dimming</td> </tr> <tr> <td>I_{INrush}</td> <td>Inrush Current</td> <td>∞</td> <td>4</td> <td>5</td> <td>A</td> <td>∞</td> </tr> <tr> <td>BL_EN</td> <td>On Control Voltage</td> <td>3</td> <td>∞</td> <td>5.5</td> <td>Volt</td> <td>∞</td> </tr> <tr> <td></td> <td>Off Control Voltage</td> <td>0</td> <td>∞</td> <td>0.5</td> <td>Volt</td> <td>∞</td> </tr> <tr> <td></td> <td>PWM Dimming Frequency</td> <td>200</td> <td>∞</td> <td>20K</td> <td>Hz</td> <td>∞</td> </tr> <tr> <td></td> <td>High Voltage</td> <td>3.0</td> <td>3.3</td> <td>5.5</td> <td>Volt</td> <td>∞</td> </tr> <tr> <td></td> <td>Low Voltage</td> <td>0</td> <td>∞</td> <td>0.5</td> <td>Volt</td> <td>∞</td> </tr> <tr> <td></td> <td>Dimming Duty 200Hz~50Hz</td> <td>5</td> <td>∞</td> <td>100</td> <td>%</td> <td>∞</td> </tr> <tr> <td></td> <td>Dimming Duty 50Hz~200Hz</td> <td>15</td> <td>∞</td> <td>100</td> <td>%</td> <td>∞</td> </tr> <tr> <td>I₀</td> <td>LED Forward Current</td> <td>∞</td> <td>90</td> <td>∞</td> <td>mA</td> <td>T_a = 25°C</td> </tr> <tr> <td>L_{TLED}</td> <td>LED Life Time</td> <td>50,000</td> <td>∞</td> <td>∞</td> <td>Hrs</td> <td>Note 4)</td> </tr> </tbody> </table>	Symbol	Parameter	Min.	Typ.	Max.	Units	Remark	V _{CC}	Input Voltage	∞	∞	∞	Volt	∞	I _{IN}	Input Current	∞	2.3	∞	A	100% Dimming	P _{LED}	Power Consumption	∞	55.2	∞	Watt	100% Dimming	I _{INrush}	Inrush Current	∞	4	5	A	∞	BL_EN	On Control Voltage	3	∞	5.5	Volt	∞		Off Control Voltage	0	∞	0.5	Volt	∞		PWM Dimming Frequency	200	∞	20K	Hz	∞		High Voltage	3.0	3.3	5.5	Volt	∞		Low Voltage	0	∞	0.5	Volt	∞		Dimming Duty 200Hz~50Hz	5	∞	100	%	∞		Dimming Duty 50Hz~200Hz	15	∞	100	%	∞	I ₀	LED Forward Current	∞	90	∞	mA	T _a = 25°C	L _{TLED}	LED Life Time	50,000	∞	∞	Hrs	Note 4)	<p>I₀ LED Forward Current</p> <p>∞ 91 ∞ mA Ta = 25°C</p>																																																																																																																																																											
Symbol	Parameter	Min.	Typ.	Max.	Units	Remark																																																																																																																																																																																																																																																										
V _{CC}	Input Voltage	∞	∞	∞	Volt	∞																																																																																																																																																																																																																																																										
I _{IN}	Input Current	∞	2.3	∞	A	100% Dimming																																																																																																																																																																																																																																																										
P _{LED}	Power Consumption	∞	55.2	∞	Watt	100% Dimming																																																																																																																																																																																																																																																										
I _{INrush}	Inrush Current	∞	4	5	A	∞																																																																																																																																																																																																																																																										
BL_EN	On Control Voltage	3	∞	5.5	Volt	∞																																																																																																																																																																																																																																																										
	Off Control Voltage	0	∞	0.5	Volt	∞																																																																																																																																																																																																																																																										
	PWM Dimming Frequency	200	∞	20K	Hz	∞																																																																																																																																																																																																																																																										
	High Voltage	3.0	3.3	5.5	Volt	∞																																																																																																																																																																																																																																																										
	Low Voltage	0	∞	0.5	Volt	∞																																																																																																																																																																																																																																																										
	Dimming Duty 200Hz~50Hz	5	∞	100	%	∞																																																																																																																																																																																																																																																										
	Dimming Duty 50Hz~200Hz	15	∞	100	%	∞																																																																																																																																																																																																																																																										
I ₀	LED Forward Current	∞	90	∞	mA	T _a = 25°C																																																																																																																																																																																																																																																										
L _{TLED}	LED Life Time	50,000	∞	∞	Hrs	Note 4)																																																																																																																																																																																																																																																										
	19																																																																																																																																																																																																																																																															
0.3 2023/09/07	11	<p>5. Electrical Characteristics¹⁾ 5.1 TFT LCD Module *5.1.1 Power Specification²⁾</p> <table border="1"> <thead> <tr> <th>Symbol</th> <th>Parameter</th> <th>Min.</th> <th>Typ.</th> <th>Max.</th> <th>Units</th> <th>Remark</th> </tr> </thead> <tbody> <tr> <td>VDD</td> <td>Logic/LCD Drive Voltage</td> <td>10.8</td> <td>12</td> <td>13.2</td> <td>[Volt]</td> <td>±10%</td> </tr> <tr> <td>IDD</td> <td>VDD Current</td> <td>TBD</td> <td>TBD</td> <td>TBD</td> <td>[mA]</td> <td>VDD= 12V, All White Pattern At 60Hz</td> </tr> <tr> <td>I_{INrush}</td> <td>LCD Inrush Current</td> <td>∞</td> <td>3</td> <td>∞</td> <td>[A]</td> <td>Note 1)</td> </tr> <tr> <td>PDD</td> <td>VDD Power</td> <td>TBD</td> <td>TBD</td> <td>TBD</td> <td>[Watt]</td> <td>VDD= 12V, All White Pattern At 60Hz</td> </tr> </tbody> </table>	Symbol	Parameter	Min.	Typ.	Max.	Units	Remark	VDD	Logic/LCD Drive Voltage	10.8	12	13.2	[Volt]	±10%	IDD	VDD Current	TBD	TBD	TBD	[mA]	VDD= 12V, All White Pattern At 60Hz	I _{INrush}	LCD Inrush Current	∞	3	∞	[A]	Note 1)	PDD	VDD Power	TBD	TBD	TBD	[Watt]	VDD= 12V, All White Pattern At 60Hz	<p>5. Electrical Characteristics¹⁾ 5.1 TFT LCD Module *5.1.1 Power Specification²⁾</p> <table border="1"> <thead> <tr> <th>Symbol</th> <th>Parameter</th> <th>Min.</th> <th>Typ.</th> <th>Max.</th> <th>Units</th> <th>Remark</th> </tr> </thead> <tbody> <tr> <td>VDD</td> <td>Logic/LCD Drive Voltage</td> <td>10.8</td> <td>12</td> <td>13.2</td> <td>[Volt]</td> <td>±10%</td> </tr> <tr> <td>IDD</td> <td>VDD Current</td> <td>∞</td> <td>400</td> <td>416.6</td> <td>[mA]</td> <td>VDD= 12V, All White Pattern At 60Hz</td> </tr> <tr> <td>I_{INrush}</td> <td>LCD Inrush Current</td> <td>∞</td> <td>3</td> <td>∞</td> <td>[A]</td> <td>Note 1)</td> </tr> <tr> <td>PDD</td> <td>VDD Power</td> <td>∞</td> <td>4.8</td> <td>5</td> <td>[Watt]</td> <td>VDD= 12V, All White Pattern At 60Hz</td> </tr> </tbody> </table>	Symbol	Parameter	Min.	Typ.	Max.	Units	Remark	VDD	Logic/LCD Drive Voltage	10.8	12	13.2	[Volt]	±10%	IDD	VDD Current	∞	400	416.6	[mA]	VDD= 12V, All White Pattern At 60Hz	I _{INrush}	LCD Inrush Current	∞	3	∞	[A]	Note 1)	PDD	VDD Power	∞	4.8	5	[Watt]	VDD= 12V, All White Pattern At 60Hz																																																																																																																																																																																							
Symbol	Parameter	Min.	Typ.	Max.	Units	Remark																																																																																																																																																																																																																																																										
VDD	Logic/LCD Drive Voltage	10.8	12	13.2	[Volt]	±10%																																																																																																																																																																																																																																																										
IDD	VDD Current	TBD	TBD	TBD	[mA]	VDD= 12V, All White Pattern At 60Hz																																																																																																																																																																																																																																																										
I _{INrush}	LCD Inrush Current	∞	3	∞	[A]	Note 1)																																																																																																																																																																																																																																																										
PDD	VDD Power	TBD	TBD	TBD	[Watt]	VDD= 12V, All White Pattern At 60Hz																																																																																																																																																																																																																																																										
Symbol	Parameter	Min.	Typ.	Max.	Units	Remark																																																																																																																																																																																																																																																										
VDD	Logic/LCD Drive Voltage	10.8	12	13.2	[Volt]	±10%																																																																																																																																																																																																																																																										
IDD	VDD Current	∞	400	416.6	[mA]	VDD= 12V, All White Pattern At 60Hz																																																																																																																																																																																																																																																										
I _{INrush}	LCD Inrush Current	∞	3	∞	[A]	Note 1)																																																																																																																																																																																																																																																										
PDD	VDD Power	∞	4.8	5	[Watt]	VDD= 12V, All White Pattern At 60Hz																																																																																																																																																																																																																																																										
	5	<p>2.1 Display Characteristics¹⁾ The following items are characteristics summary on the table under 25 °C condition.²⁾</p> <table border="1"> <thead> <tr> <th>ITEMS</th> <th>Unit</th> <th>SPECIFICATIONS</th> </tr> </thead> <tbody> <tr> <td>Screen Diagonal</td> <td>[mm]</td> <td>609.7(24.0")</td> </tr> <tr> <td>Active Area</td> <td>[mm]</td> <td>531.36 (H) x 298.89 (V)</td> </tr> <tr> <td>Pixels H x V</td> <td></td> <td>1920(X) x 1080</td> </tr> <tr> <td>Pixel Pitch</td> <td>[µm]</td> <td>276.75 (per one triad) x 276.75</td> </tr> <tr> <td>Pixel Arrangement</td> <td></td> <td>R.G.B. Vertical Stripe</td> </tr> <tr> <td>Display Mode</td> <td></td> <td>VA Mode, Normally Black</td> </tr> <tr> <td>White Luminance (Center)</td> <td>[cd/m²]</td> <td>1500</td> </tr> <tr> <td>Contrast Ratio</td> <td></td> <td>5000:1</td> </tr> <tr> <td>Optical Response Time</td> <td>[msec]</td> <td>TBD</td> </tr> <tr> <td>Normal Input Voltage VDD</td> <td>[Volt]</td> <td>+12.0 V</td> </tr> <tr> <td>Power Consumption</td> <td>[Watt]</td> <td>67.2 W (Cell: 4.8 + BL: 62.4) (Typ)@White: 79.9 W (Cell: 5.0 + BL: 74.9) (Max)@White</td> </tr> </tbody> </table>	ITEMS	Unit	SPECIFICATIONS	Screen Diagonal	[mm]	609.7(24.0")	Active Area	[mm]	531.36 (H) x 298.89 (V)	Pixels H x V		1920(X) x 1080	Pixel Pitch	[µm]	276.75 (per one triad) x 276.75	Pixel Arrangement		R.G.B. Vertical Stripe	Display Mode		VA Mode, Normally Black	White Luminance (Center)	[cd/m ²]	1500	Contrast Ratio		5000:1	Optical Response Time	[msec]	TBD	Normal Input Voltage VDD	[Volt]	+12.0 V	Power Consumption	[Watt]	67.2 W (Cell: 4.8 + BL: 62.4) (Typ)@White: 79.9 W (Cell: 5.0 + BL: 74.9) (Max)@White	<p>2.1 Display Characteristics¹⁾ The following items are characteristics summary on the table under 25 °C condition.²⁾</p> <table border="1"> <thead> <tr> <th>ITEMS</th> <th>Unit</th> <th>SPECIFICATIONS</th> </tr> </thead> <tbody> <tr> <td>Screen Diagonal</td> <td>[mm]</td> <td>609.7(24.0")</td> </tr> <tr> <td>Active Area</td> <td>[mm]</td> <td>531.36 (H) x 298.89 (V)</td> </tr> <tr> <td>Pixels H x V</td> <td></td> <td>1920(X) x 1080</td> </tr> <tr> <td>Pixel Pitch</td> <td>[µm]</td> <td>276.75 (per one triad) x 276.75</td> </tr> <tr> <td>Pixel Arrangement</td> <td></td> <td>R.G.B. Vertical Stripe</td> </tr> <tr> <td>Display Mode</td> <td></td> <td>VA Mode, Normally Black</td> </tr> <tr> <td>White Luminance (Center)</td> <td>[cd/m²]</td> <td>1500</td> </tr> <tr> <td>Contrast Ratio</td> <td></td> <td>5000:1</td> </tr> <tr> <td>Optical Response Time</td> <td>[msec]</td> <td>TBD</td> </tr> <tr> <td>Normal Input Voltage VDD</td> <td>[Volt]</td> <td>+12.0 V</td> </tr> <tr> <td>Power Consumption</td> <td>[Watt]</td> <td>67.2 W (Cell: 4.8 + BL: 62.4) (Typ)@White</td> </tr> </tbody> </table>	ITEMS	Unit	SPECIFICATIONS	Screen Diagonal	[mm]	609.7(24.0")	Active Area	[mm]	531.36 (H) x 298.89 (V)	Pixels H x V		1920(X) x 1080	Pixel Pitch	[µm]	276.75 (per one triad) x 276.75	Pixel Arrangement		R.G.B. Vertical Stripe	Display Mode		VA Mode, Normally Black	White Luminance (Center)	[cd/m ²]	1500	Contrast Ratio		5000:1	Optical Response Time	[msec]	TBD	Normal Input Voltage VDD	[Volt]	+12.0 V	Power Consumption	[Watt]	67.2 W (Cell: 4.8 + BL: 62.4) (Typ)@White																																																																																																																																																																																					
ITEMS	Unit	SPECIFICATIONS																																																																																																																																																																																																																																																														
Screen Diagonal	[mm]	609.7(24.0")																																																																																																																																																																																																																																																														
Active Area	[mm]	531.36 (H) x 298.89 (V)																																																																																																																																																																																																																																																														
Pixels H x V		1920(X) x 1080																																																																																																																																																																																																																																																														
Pixel Pitch	[µm]	276.75 (per one triad) x 276.75																																																																																																																																																																																																																																																														
Pixel Arrangement		R.G.B. Vertical Stripe																																																																																																																																																																																																																																																														
Display Mode		VA Mode, Normally Black																																																																																																																																																																																																																																																														
White Luminance (Center)	[cd/m ²]	1500																																																																																																																																																																																																																																																														
Contrast Ratio		5000:1																																																																																																																																																																																																																																																														
Optical Response Time	[msec]	TBD																																																																																																																																																																																																																																																														
Normal Input Voltage VDD	[Volt]	+12.0 V																																																																																																																																																																																																																																																														
Power Consumption	[Watt]	67.2 W (Cell: 4.8 + BL: 62.4) (Typ)@White: 79.9 W (Cell: 5.0 + BL: 74.9) (Max)@White																																																																																																																																																																																																																																																														
ITEMS	Unit	SPECIFICATIONS																																																																																																																																																																																																																																																														
Screen Diagonal	[mm]	609.7(24.0")																																																																																																																																																																																																																																																														
Active Area	[mm]	531.36 (H) x 298.89 (V)																																																																																																																																																																																																																																																														
Pixels H x V		1920(X) x 1080																																																																																																																																																																																																																																																														
Pixel Pitch	[µm]	276.75 (per one triad) x 276.75																																																																																																																																																																																																																																																														
Pixel Arrangement		R.G.B. Vertical Stripe																																																																																																																																																																																																																																																														
Display Mode		VA Mode, Normally Black																																																																																																																																																																																																																																																														
White Luminance (Center)	[cd/m ²]	1500																																																																																																																																																																																																																																																														
Contrast Ratio		5000:1																																																																																																																																																																																																																																																														
Optical Response Time	[msec]	TBD																																																																																																																																																																																																																																																														
Normal Input Voltage VDD	[Volt]	+12.0 V																																																																																																																																																																																																																																																														
Power Consumption	[Watt]	67.2 W (Cell: 4.8 + BL: 62.4) (Typ)@White																																																																																																																																																																																																																																																														
	6	<p>2.2 Optical Characteristics¹⁾ The optical characteristics are measured under stable conditions at 25°C (Room Temperature).²⁾</p> <table border="1"> <thead> <tr> <th>Item</th> <th>Unit</th> <th>Conditions</th> <th>Min.</th> <th>Typ.</th> <th>Max.</th> <th>Note</th> </tr> </thead> <tbody> <tr> <td>White Luminance</td> <td>[cd/m²]</td> <td>I₀ = 91 mA</td> <td>1200</td> <td>1500</td> <td>∞</td> <td>1)</td> </tr> <tr> <td>Uniformity</td> <td>%</td> <td>9 Points</td> <td>75</td> <td>80</td> <td>∞</td> <td>1, 2, 3)</td> </tr> <tr> <td>Contrast Ratio</td> <td></td> <td></td> <td>3000</td> <td>5000</td> <td>∞</td> <td>4)</td> </tr> <tr> <td>Cross talk</td> <td>%</td> <td>Rising</td> <td>∞</td> <td>TBD</td> <td>∞</td> <td>5)</td> </tr> <tr> <td></td> <td></td> <td>Falling</td> <td>∞</td> <td>TBD</td> <td>∞</td> <td></td> </tr> <tr> <td>Response Time</td> <td>[msec]</td> <td>Rising + Falling</td> <td>∞</td> <td>TBD</td> <td>TBD</td> <td>6)</td> </tr> <tr> <td>Viewing Angle</td> <td>[degree]</td> <td>Horizontal (Right) (Left)</td> <td>∞</td> <td>85</td> <td>∞</td> <td></td> </tr> <tr> <td></td> <td></td> <td>Vertical (Upper) (Lower)</td> <td>∞</td> <td>80</td> <td>∞</td> <td>7)</td> </tr> <tr> <td>Color / Chromaticity Coordinates (CIE 1931)</td> <td></td> <td>Red x⁰</td> <td>TBD</td> <td>TBD</td> <td>TBD</td> <td></td> </tr> <tr> <td></td> <td></td> <td>Red y⁰</td> <td>TBD</td> <td>TBD</td> <td>TBD</td> <td></td> </tr> <tr> <td></td> <td></td> <td>Green x⁰</td> <td>TBD</td> <td>TBD</td> <td>TBD</td> <td></td> </tr> <tr> <td></td> <td></td> <td>Green y⁰</td> <td>TBD</td> <td>TBD</td> <td>TBD</td> <td></td> </tr> <tr> <td></td> <td></td> <td>Blue x⁰</td> <td>TBD</td> <td>TBD</td> <td>TBD</td> <td></td> </tr> <tr> <td></td> <td></td> <td>Blue y⁰</td> <td>TBD</td> <td>TBD</td> <td>TBD</td> <td></td> </tr> <tr> <td></td> <td></td> <td>White x⁰</td> <td>0.263</td> <td>0.313</td> <td>0.363</td> <td></td> </tr> <tr> <td></td> <td></td> <td>White y⁰</td> <td>0.279</td> <td>0.329</td> <td>0.379</td> <td></td> </tr> <tr> <td>Color Gamut</td> <td>%</td> <td></td> <td>∞</td> <td>72</td> <td>∞</td> <td></td> </tr> </tbody> </table>	Item	Unit	Conditions	Min.	Typ.	Max.	Note	White Luminance	[cd/m ²]	I ₀ = 91 mA	1200	1500	∞	1)	Uniformity	%	9 Points	75	80	∞	1, 2, 3)	Contrast Ratio			3000	5000	∞	4)	Cross talk	%	Rising	∞	TBD	∞	5)			Falling	∞	TBD	∞		Response Time	[msec]	Rising + Falling	∞	TBD	TBD	6)	Viewing Angle	[degree]	Horizontal (Right) (Left)	∞	85	∞				Vertical (Upper) (Lower)	∞	80	∞	7)	Color / Chromaticity Coordinates (CIE 1931)		Red x ⁰	TBD	TBD	TBD				Red y ⁰	TBD	TBD	TBD				Green x ⁰	TBD	TBD	TBD				Green y ⁰	TBD	TBD	TBD				Blue x ⁰	TBD	TBD	TBD				Blue y ⁰	TBD	TBD	TBD				White x ⁰	0.263	0.313	0.363				White y ⁰	0.279	0.329	0.379		Color Gamut	%		∞	72	∞		<p>2.2 Optical Characteristics¹⁾ The optical characteristics are measured under stable conditions at 25°C (Room Temperature).²⁾</p> <table border="1"> <thead> <tr> <th>Item</th> <th>Unit</th> <th>Conditions</th> <th>Min.</th> <th>Typ.</th> <th>Max.</th> <th>Note</th> </tr> </thead> <tbody> <tr> <td>White Luminance</td> <td>[cd/m²]</td> <td>I₀ = 91 mA</td> <td>1200</td> <td>1500</td> <td>∞</td> <td>1)</td> </tr> <tr> <td>Uniformity</td> <td>%</td> <td>9 Points</td> <td>75</td> <td>80</td> <td>∞</td> <td>1, 2, 3)</td> </tr> <tr> <td>Contrast Ratio</td> <td></td> <td></td> <td>3000</td> <td>5000</td> <td>∞</td> <td>4)</td> </tr> <tr> <td>Cross talk</td> <td>%</td> <td>Rising</td> <td>∞</td> <td>16</td> <td>∞</td> <td>5)</td> </tr> <tr> <td></td> <td></td> <td>Falling</td> <td>∞</td> <td>9</td> <td>∞</td> <td></td> </tr> <tr> <td>Response Time</td> <td>[msec]</td> <td>Rising + Falling</td> <td>∞</td> <td>25</td> <td>50</td> <td>6)</td> </tr> <tr> <td>Viewing Angle</td> <td>[degree]</td> <td>Horizontal (Right) (Left)</td> <td>∞</td> <td>85</td> <td>∞</td> <td></td> </tr> <tr> <td></td> <td></td> <td>Vertical (Upper) (Lower)</td> <td>∞</td> <td>80</td> <td>∞</td> <td>7)</td> </tr> <tr> <td>Color / Chromaticity Coordinates (CIE 1931)</td> <td></td> <td>Red x⁰</td> <td>0.602</td> <td>0.652</td> <td>0.702</td> <td></td> </tr> <tr> <td></td> <td></td> <td>Red y⁰</td> <td>0.285</td> <td>0.335</td> <td>0.385</td> <td></td> </tr> <tr> <td></td> <td></td> <td>Green x⁰</td> <td>0.271</td> <td>0.321</td> <td>0.371</td> <td></td> </tr> <tr> <td></td> <td></td> <td>Green y⁰</td> <td>0.568</td> <td>0.618</td> <td>0.668</td> <td></td> </tr> <tr> <td></td> <td></td> <td>Blue x⁰</td> <td>0.101</td> <td>0.151</td> <td>0.201</td> <td></td> </tr> <tr> <td></td> <td></td> <td>Blue y⁰</td> <td>0.009</td> <td>0.059</td> <td>0.109</td> <td></td> </tr> <tr> <td></td> <td></td> <td>White x⁰</td> <td>0.263</td> <td>0.313</td> <td>0.363</td> <td></td> </tr> <tr> <td></td> <td></td> <td>White y⁰</td> <td>0.279</td> <td>0.329</td> <td>0.379</td> <td></td> </tr> <tr> <td>Color Gamut</td> <td>%</td> <td></td> <td>∞</td> <td>72</td> <td>∞</td> <td></td> </tr> </tbody> </table>	Item	Unit	Conditions	Min.	Typ.	Max.	Note	White Luminance	[cd/m ²]	I ₀ = 91 mA	1200	1500	∞	1)	Uniformity	%	9 Points	75	80	∞	1, 2, 3)	Contrast Ratio			3000	5000	∞	4)	Cross talk	%	Rising	∞	16	∞	5)			Falling	∞	9	∞		Response Time	[msec]	Rising + Falling	∞	25	50	6)	Viewing Angle	[degree]	Horizontal (Right) (Left)	∞	85	∞				Vertical (Upper) (Lower)	∞	80	∞	7)	Color / Chromaticity Coordinates (CIE 1931)		Red x ⁰	0.602	0.652	0.702				Red y ⁰	0.285	0.335	0.385				Green x ⁰	0.271	0.321	0.371				Green y ⁰	0.568	0.618	0.668				Blue x ⁰	0.101	0.151	0.201				Blue y ⁰	0.009	0.059	0.109				White x ⁰	0.263	0.313	0.363				White y ⁰	0.279	0.329	0.379		Color Gamut	%		∞	72	∞		
Item	Unit	Conditions	Min.	Typ.	Max.	Note																																																																																																																																																																																																																																																										
White Luminance	[cd/m ²]	I ₀ = 91 mA	1200	1500	∞	1)																																																																																																																																																																																																																																																										
Uniformity	%	9 Points	75	80	∞	1, 2, 3)																																																																																																																																																																																																																																																										
Contrast Ratio			3000	5000	∞	4)																																																																																																																																																																																																																																																										
Cross talk	%	Rising	∞	TBD	∞	5)																																																																																																																																																																																																																																																										
		Falling	∞	TBD	∞																																																																																																																																																																																																																																																											
Response Time	[msec]	Rising + Falling	∞	TBD	TBD	6)																																																																																																																																																																																																																																																										
Viewing Angle	[degree]	Horizontal (Right) (Left)	∞	85	∞																																																																																																																																																																																																																																																											
		Vertical (Upper) (Lower)	∞	80	∞	7)																																																																																																																																																																																																																																																										
Color / Chromaticity Coordinates (CIE 1931)		Red x ⁰	TBD	TBD	TBD																																																																																																																																																																																																																																																											
		Red y ⁰	TBD	TBD	TBD																																																																																																																																																																																																																																																											
		Green x ⁰	TBD	TBD	TBD																																																																																																																																																																																																																																																											
		Green y ⁰	TBD	TBD	TBD																																																																																																																																																																																																																																																											
		Blue x ⁰	TBD	TBD	TBD																																																																																																																																																																																																																																																											
		Blue y ⁰	TBD	TBD	TBD																																																																																																																																																																																																																																																											
		White x ⁰	0.263	0.313	0.363																																																																																																																																																																																																																																																											
		White y ⁰	0.279	0.329	0.379																																																																																																																																																																																																																																																											
Color Gamut	%		∞	72	∞																																																																																																																																																																																																																																																											
Item	Unit	Conditions	Min.	Typ.	Max.	Note																																																																																																																																																																																																																																																										
White Luminance	[cd/m ²]	I ₀ = 91 mA	1200	1500	∞	1)																																																																																																																																																																																																																																																										
Uniformity	%	9 Points	75	80	∞	1, 2, 3)																																																																																																																																																																																																																																																										
Contrast Ratio			3000	5000	∞	4)																																																																																																																																																																																																																																																										
Cross talk	%	Rising	∞	16	∞	5)																																																																																																																																																																																																																																																										
		Falling	∞	9	∞																																																																																																																																																																																																																																																											
Response Time	[msec]	Rising + Falling	∞	25	50	6)																																																																																																																																																																																																																																																										
Viewing Angle	[degree]	Horizontal (Right) (Left)	∞	85	∞																																																																																																																																																																																																																																																											
		Vertical (Upper) (Lower)	∞	80	∞	7)																																																																																																																																																																																																																																																										
Color / Chromaticity Coordinates (CIE 1931)		Red x ⁰	0.602	0.652	0.702																																																																																																																																																																																																																																																											
		Red y ⁰	0.285	0.335	0.385																																																																																																																																																																																																																																																											
		Green x ⁰	0.271	0.321	0.371																																																																																																																																																																																																																																																											
		Green y ⁰	0.568	0.618	0.668																																																																																																																																																																																																																																																											
		Blue x ⁰	0.101	0.151	0.201																																																																																																																																																																																																																																																											
		Blue y ⁰	0.009	0.059	0.109																																																																																																																																																																																																																																																											
		White x ⁰	0.263	0.313	0.363																																																																																																																																																																																																																																																											
		White y ⁰	0.279	0.329	0.379																																																																																																																																																																																																																																																											
Color Gamut	%		∞	72	∞																																																																																																																																																																																																																																																											

10	<p>4. Absolute Maximum Ratings ¹⁾</p> <p>4.1 TFT LCD Module ¹⁾</p> <table border="1"> <thead> <tr> <th>Item</th> <th>Symbol</th> <th>Min</th> <th>Max</th> <th>Unit</th> <th>Conditions</th> </tr> </thead> <tbody> <tr> <td>Logic/LCD Drive Voltage</td> <td>VDD</td> <td>9.5</td> <td>14</td> <td>[Volt]</td> <td>Note 1, 2</td> </tr> </tbody> </table> <p>4.2 Backlight Unit ¹⁾</p> <table border="1"> <thead> <tr> <th>Item</th> <th>Symbol</th> <th>Min</th> <th>Max</th> <th>Unit</th> <th>Conditions</th> </tr> </thead> <tbody> <tr> <td>LED Input Voltage</td> <td>Vcc</td> <td>23.5</td> <td>24.5</td> <td>[Volt]</td> <td>Note 1, 2</td> </tr> </tbody> </table>	Item	Symbol	Min	Max	Unit	Conditions	Logic/LCD Drive Voltage	VDD	9.5	14	[Volt]	Note 1, 2	Item	Symbol	Min	Max	Unit	Conditions	LED Input Voltage	Vcc	23.5	24.5	[Volt]	Note 1, 2	<p>4. Absolute Maximum Ratings ¹⁾</p> <p>4.1 TFT LCD Module ¹⁾</p> <table border="1"> <thead> <tr> <th>Item</th> <th>Symbol</th> <th>Min</th> <th>Max</th> <th>Unit</th> <th>Conditions</th> </tr> </thead> <tbody> <tr> <td>Logic/LCD Drive Voltage</td> <td>VDD</td> <td>GND-0.3</td> <td>13.2</td> <td>[Volt]</td> <td>Note 1, 2</td> </tr> </tbody> </table> <p>4.2 Backlight Unit ¹⁾</p> <table border="1"> <thead> <tr> <th>Item</th> <th>Symbol</th> <th>Min</th> <th>Max</th> <th>Unit</th> <th>Conditions</th> </tr> </thead> <tbody> <tr> <td>LED Input Voltage</td> <td>Vcc</td> <td>GND-0.3</td> <td>24.5</td> <td>[Volt]</td> <td>Note 1, 2</td> </tr> </tbody> </table>	Item	Symbol	Min	Max	Unit	Conditions	Logic/LCD Drive Voltage	VDD	GND-0.3	13.2	[Volt]	Note 1, 2	Item	Symbol	Min	Max	Unit	Conditions	LED Input Voltage	Vcc	GND-0.3	24.5	[Volt]	Note 1, 2																																																																																																																																																													
Item	Symbol	Min	Max	Unit	Conditions																																																																																																																																																																																																										
Logic/LCD Drive Voltage	VDD	9.5	14	[Volt]	Note 1, 2																																																																																																																																																																																																										
Item	Symbol	Min	Max	Unit	Conditions																																																																																																																																																																																																										
LED Input Voltage	Vcc	23.5	24.5	[Volt]	Note 1, 2																																																																																																																																																																																																										
Item	Symbol	Min	Max	Unit	Conditions																																																																																																																																																																																																										
Logic/LCD Drive Voltage	VDD	GND-0.3	13.2	[Volt]	Note 1, 2																																																																																																																																																																																																										
Item	Symbol	Min	Max	Unit	Conditions																																																																																																																																																																																																										
LED Input Voltage	Vcc	GND-0.3	24.5	[Volt]	Note 1, 2																																																																																																																																																																																																										
12	<p>AUO Display+ ¹⁾</p> <p>5. Electrical Characteristics ¹⁾</p> <p>5.1 TFT LCD Module ¹⁾</p> <p>5.1.1 Power Specification ¹⁾</p> <table border="1"> <thead> <tr> <th>Symbol</th> <th>Parameter</th> <th>Min</th> <th>Typ</th> <th>Max</th> <th>Units</th> <th>Remark</th> </tr> </thead> <tbody> <tr> <td>VDD</td> <td>Logic/LCD Drive Voltage</td> <td>10.8</td> <td>12</td> <td>13.2</td> <td>[Volt]</td> <td>±10%</td> </tr> <tr> <td>IDD</td> <td>VDD Current</td> <td>400</td> <td>416.6</td> <td>450</td> <td>[mA]</td> <td>VDD=12V, All White Pattern, At 60Hz</td> </tr> <tr> <td>I_{inrush}</td> <td>LCD Inrush Current</td> <td>3</td> <td>3</td> <td>3</td> <td>[A]</td> <td>Note 1, 2</td> </tr> <tr> <td>PDD</td> <td>VDD Power</td> <td>4.8</td> <td>5</td> <td>5.76</td> <td>[Watt]</td> <td>VDD=12V, All White Pattern, At 60Hz</td> </tr> </tbody> </table>	Symbol	Parameter	Min	Typ	Max	Units	Remark	VDD	Logic/LCD Drive Voltage	10.8	12	13.2	[Volt]	±10%	IDD	VDD Current	400	416.6	450	[mA]	VDD=12V, All White Pattern, At 60Hz	I _{inrush}	LCD Inrush Current	3	3	3	[A]	Note 1, 2	PDD	VDD Power	4.8	5	5.76	[Watt]	VDD=12V, All White Pattern, At 60Hz	<p>5. Electrical Characteristics ¹⁾</p> <p>5.1 TFT LCD Module ¹⁾</p> <p>5.1.1 Power Specification ¹⁾</p> <table border="1"> <thead> <tr> <th>Symbol</th> <th>Parameter</th> <th>Min</th> <th>Typ</th> <th>Max</th> <th>Units</th> <th>Remark</th> </tr> </thead> <tbody> <tr> <td>VDD</td> <td>Logic/LCD Drive Voltage</td> <td>10.8</td> <td>12</td> <td>13.2</td> <td>[Volt]</td> <td>±10%</td> </tr> <tr> <td>IDD</td> <td>VDD Current</td> <td>400</td> <td>416.6</td> <td>450</td> <td>[mA]</td> <td>VDD=12V, All White Pattern, At 60Hz</td> </tr> <tr> <td>I_{inrush}</td> <td>LCD Inrush Current</td> <td>3</td> <td>3</td> <td>3</td> <td>[A]</td> <td>Note 1, 2</td> </tr> <tr> <td>PDD</td> <td>VDD Power</td> <td>4.8</td> <td>5</td> <td>5.76</td> <td>[Watt]</td> <td>VDD=12V, All White Pattern, At 60Hz</td> </tr> </tbody> </table>	Symbol	Parameter	Min	Typ	Max	Units	Remark	VDD	Logic/LCD Drive Voltage	10.8	12	13.2	[Volt]	±10%	IDD	VDD Current	400	416.6	450	[mA]	VDD=12V, All White Pattern, At 60Hz	I _{inrush}	LCD Inrush Current	3	3	3	[A]	Note 1, 2	PDD	VDD Power	4.8	5	5.76	[Watt]	VDD=12V, All White Pattern, At 60Hz																																																																																																																																							
Symbol	Parameter	Min	Typ	Max	Units	Remark																																																																																																																																																																																																									
VDD	Logic/LCD Drive Voltage	10.8	12	13.2	[Volt]	±10%																																																																																																																																																																																																									
IDD	VDD Current	400	416.6	450	[mA]	VDD=12V, All White Pattern, At 60Hz																																																																																																																																																																																																									
I _{inrush}	LCD Inrush Current	3	3	3	[A]	Note 1, 2																																																																																																																																																																																																									
PDD	VDD Power	4.8	5	5.76	[Watt]	VDD=12V, All White Pattern, At 60Hz																																																																																																																																																																																																									
Symbol	Parameter	Min	Typ	Max	Units	Remark																																																																																																																																																																																																									
VDD	Logic/LCD Drive Voltage	10.8	12	13.2	[Volt]	±10%																																																																																																																																																																																																									
IDD	VDD Current	400	416.6	450	[mA]	VDD=12V, All White Pattern, At 60Hz																																																																																																																																																																																																									
I _{inrush}	LCD Inrush Current	3	3	3	[A]	Note 1, 2																																																																																																																																																																																																									
PDD	VDD Power	4.8	5	5.76	[Watt]	VDD=12V, All White Pattern, At 60Hz																																																																																																																																																																																																									
18	<p>6.4 Interface Timing ¹⁾</p> <p>6.4.1 Timing Characteristics ¹⁾</p> <table border="1"> <thead> <tr> <th>Signal</th> <th>Item</th> <th>Symbol</th> <th>Min</th> <th>Typ</th> <th>Max</th> <th>Unit</th> </tr> </thead> <tbody> <tr> <td rowspan="2">Clock</td> <td>Frequency</td> <td>f_{clk}</td> <td>TBD</td> <td>72</td> <td>TBD</td> <td>MHz</td> </tr> <tr> <td>Frame Rate</td> <td>F_{rate}</td> <td>1/7</td> <td>60</td> <td>TBD</td> <td>Hz</td> </tr> <tr> <td rowspan="3">Vertical Section</td> <td>Active</td> <td>T_{act}</td> <td>TBD</td> <td>1120</td> <td>TBD</td> <td>Line</td> </tr> <tr> <td>Blanking</td> <td>T_{bl}</td> <td>TBD</td> <td>40</td> <td>TBD</td> <td>Line</td> </tr> <tr> <td>Period</td> <td>T_{per}</td> <td>TBD</td> <td>1060</td> <td>TBD</td> <td>Line</td> </tr> <tr> <td rowspan="3">Horizontal Section</td> <td>Active</td> <td>T_{act}</td> <td>TBD</td> <td>960</td> <td>TBD</td> <td>Line</td> </tr> <tr> <td>Blanking</td> <td>T_{bl}</td> <td>TBD</td> <td>100</td> <td>TBD</td> <td>Line</td> </tr> <tr> <td>Period</td> <td>T_{per}</td> <td>TBD</td> <td>1000</td> <td>TBD</td> <td>Line</td> </tr> </tbody> </table> <p>Note: DE mode only ¹⁾</p>	Signal	Item	Symbol	Min	Typ	Max	Unit	Clock	Frequency	f _{clk}	TBD	72	TBD	MHz	Frame Rate	F _{rate}	1/7	60	TBD	Hz	Vertical Section	Active	T _{act}	TBD	1120	TBD	Line	Blanking	T _{bl}	TBD	40	TBD	Line	Period	T _{per}	TBD	1060	TBD	Line	Horizontal Section	Active	T _{act}	TBD	960	TBD	Line	Blanking	T _{bl}	TBD	100	TBD	Line	Period	T _{per}	TBD	1000	TBD	Line	<p>6.4 Interface Timing ¹⁾</p> <p>6.4.1 Timing Characteristics ¹⁾</p> <table border="1"> <thead> <tr> <th>Signal</th> <th>Item</th> <th>Symbol</th> <th>Min</th> <th>Typ</th> <th>Max</th> <th>Unit</th> </tr> </thead> <tbody> <tr> <td rowspan="2">Clock</td> <td>Frequency</td> <td>f_{clk}</td> <td>40</td> <td>72</td> <td>83</td> <td>MHz</td> </tr> <tr> <td>Frame Rate</td> <td>F_{rate}</td> <td>1/7</td> <td>50</td> <td>60</td> <td>Hz</td> </tr> <tr> <td rowspan="3">Vertical Section</td> <td>Active</td> <td>T_{act}</td> <td>1080</td> <td>1120</td> <td>1080</td> <td>Line</td> </tr> <tr> <td>Blanking</td> <td>T_{bl}</td> <td>40</td> <td>40</td> <td>967</td> <td>Line</td> </tr> <tr> <td>Period</td> <td>T_{per}</td> <td>1034</td> <td>1060</td> <td>2047</td> <td>Line</td> </tr> <tr> <td rowspan="3">Horizontal Section</td> <td>Active</td> <td>T_{act}</td> <td>960</td> <td>960</td> <td>960</td> <td>Line</td> </tr> <tr> <td>Blanking</td> <td>T_{bl}</td> <td>74</td> <td>100</td> <td>1087</td> <td>Line</td> </tr> <tr> <td>Period</td> <td>T_{per}</td> <td>1034</td> <td>1060</td> <td>2047</td> <td>Line</td> </tr> </tbody> </table>	Signal	Item	Symbol	Min	Typ	Max	Unit	Clock	Frequency	f _{clk}	40	72	83	MHz	Frame Rate	F _{rate}	1/7	50	60	Hz	Vertical Section	Active	T _{act}	1080	1120	1080	Line	Blanking	T _{bl}	40	40	967	Line	Period	T _{per}	1034	1060	2047	Line	Horizontal Section	Active	T _{act}	960	960	960	Line	Blanking	T _{bl}	74	100	1087	Line	Period	T _{per}	1034	1060	2047	Line																																																																																									
Signal	Item	Symbol	Min	Typ	Max	Unit																																																																																																																																																																																																									
Clock	Frequency	f _{clk}	TBD	72	TBD	MHz																																																																																																																																																																																																									
	Frame Rate	F _{rate}	1/7	60	TBD	Hz																																																																																																																																																																																																									
Vertical Section	Active	T _{act}	TBD	1120	TBD	Line																																																																																																																																																																																																									
	Blanking	T _{bl}	TBD	40	TBD	Line																																																																																																																																																																																																									
	Period	T _{per}	TBD	1060	TBD	Line																																																																																																																																																																																																									
Horizontal Section	Active	T _{act}	TBD	960	TBD	Line																																																																																																																																																																																																									
	Blanking	T _{bl}	TBD	100	TBD	Line																																																																																																																																																																																																									
	Period	T _{per}	TBD	1000	TBD	Line																																																																																																																																																																																																									
Signal	Item	Symbol	Min	Typ	Max	Unit																																																																																																																																																																																																									
Clock	Frequency	f _{clk}	40	72	83	MHz																																																																																																																																																																																																									
	Frame Rate	F _{rate}	1/7	50	60	Hz																																																																																																																																																																																																									
Vertical Section	Active	T _{act}	1080	1120	1080	Line																																																																																																																																																																																																									
	Blanking	T _{bl}	40	40	967	Line																																																																																																																																																																																																									
	Period	T _{per}	1034	1060	2047	Line																																																																																																																																																																																																									
Horizontal Section	Active	T _{act}	960	960	960	Line																																																																																																																																																																																																									
	Blanking	T _{bl}	74	100	1087	Line																																																																																																																																																																																																									
	Period	T _{per}	1034	1060	2047	Line																																																																																																																																																																																																									
0.4 2023/9/25	<p>2.1 Display Characteristics ¹⁾</p> <p>The following items are characteristics summary on the table under 25°C condition: ¹⁾</p> <table border="1"> <thead> <tr> <th>ITEMS</th> <th>Unit</th> <th>SPECIFICATIONS</th> </tr> </thead> <tbody> <tr> <td>Screen Diagonal</td> <td>[mm]</td> <td>600 (24.0")</td> </tr> <tr> <td>Active Area</td> <td>[mm]</td> <td>531.36 (H) x 298.89 (V)</td> </tr> <tr> <td>Pixels H x V</td> <td></td> <td>1920(x3) x 1080</td> </tr> <tr> <td>Pixel Pitch</td> <td>[μm]</td> <td>276.75 (per one triad) x 276.75</td> </tr> <tr> <td>Pixel Arrangement</td> <td></td> <td>R.G.B. Vertical Stripe</td> </tr> <tr> <td>Display Mode</td> <td></td> <td>VA Mode, Normally Black</td> </tr> <tr> <td>White Luminance (Center)</td> <td>[cd/m²]</td> <td>1500</td> </tr> <tr> <td>Contrast Ratio</td> <td></td> <td>5000:1</td> </tr> <tr> <td>Optical Response Time</td> <td>[msec]</td> <td>TBD</td> </tr> <tr> <td>Nominal Input Voltage VDD</td> <td>[Volt]</td> <td>+12.0 V</td> </tr> <tr> <td>Power Consumption</td> <td>[Watt]</td> <td>67.2 W (Cell: 4.8 + BL: 62.4) (Typ)@White</td> </tr> </tbody> </table>	ITEMS	Unit	SPECIFICATIONS	Screen Diagonal	[mm]	600 (24.0")	Active Area	[mm]	531.36 (H) x 298.89 (V)	Pixels H x V		1920(x3) x 1080	Pixel Pitch	[μm]	276.75 (per one triad) x 276.75	Pixel Arrangement		R.G.B. Vertical Stripe	Display Mode		VA Mode, Normally Black	White Luminance (Center)	[cd/m ²]	1500	Contrast Ratio		5000:1	Optical Response Time	[msec]	TBD	Nominal Input Voltage VDD	[Volt]	+12.0 V	Power Consumption	[Watt]	67.2 W (Cell: 4.8 + BL: 62.4) (Typ)@White	<p>2.1 Display Characteristics ¹⁾</p> <p>The following items are characteristics summary on the table under 25°C condition: ¹⁾</p> <table border="1"> <thead> <tr> <th>ITEMS</th> <th>Unit</th> <th>SPECIFICATIONS</th> </tr> </thead> <tbody> <tr> <td>Screen Diagonal</td> <td>[mm]</td> <td>600 (24.0")</td> </tr> <tr> <td>Active Area</td> <td>[mm]</td> <td>531.36 (H) x 298.89 (V)</td> </tr> <tr> <td>Pixels H x V</td> <td></td> <td>1920(x3) x 1080</td> </tr> <tr> <td>Pixel Pitch</td> <td>[μm]</td> <td>276.75 (per one triad) x 276.75</td> </tr> <tr> <td>Pixel Arrangement</td> <td></td> <td>R.G.B. Vertical Stripe</td> </tr> <tr> <td>Display Mode</td> <td></td> <td>VA Mode, Normally Black</td> </tr> <tr> <td>White Luminance (Center)</td> <td>[cd/m²]</td> <td>1500</td> </tr> <tr> <td>Contrast Ratio</td> <td></td> <td>5000:1</td> </tr> <tr> <td>Optical Response Time</td> <td>[msec]</td> <td>25</td> </tr> <tr> <td>Nominal Input Voltage VDD</td> <td>[Volt]</td> <td>+12.0 V</td> </tr> <tr> <td>Power Consumption</td> <td>[Watt]</td> <td>69.8 W (Cell: 4.8 + BL: 65) (Typ)@White</td> </tr> </tbody> </table>	ITEMS	Unit	SPECIFICATIONS	Screen Diagonal	[mm]	600 (24.0")	Active Area	[mm]	531.36 (H) x 298.89 (V)	Pixels H x V		1920(x3) x 1080	Pixel Pitch	[μm]	276.75 (per one triad) x 276.75	Pixel Arrangement		R.G.B. Vertical Stripe	Display Mode		VA Mode, Normally Black	White Luminance (Center)	[cd/m ²]	1500	Contrast Ratio		5000:1	Optical Response Time	[msec]	25	Nominal Input Voltage VDD	[Volt]	+12.0 V	Power Consumption	[Watt]	69.8 W (Cell: 4.8 + BL: 65) (Typ)@White																																																																																																																																					
ITEMS	Unit	SPECIFICATIONS																																																																																																																																																																																																													
Screen Diagonal	[mm]	600 (24.0")																																																																																																																																																																																																													
Active Area	[mm]	531.36 (H) x 298.89 (V)																																																																																																																																																																																																													
Pixels H x V		1920(x3) x 1080																																																																																																																																																																																																													
Pixel Pitch	[μm]	276.75 (per one triad) x 276.75																																																																																																																																																																																																													
Pixel Arrangement		R.G.B. Vertical Stripe																																																																																																																																																																																																													
Display Mode		VA Mode, Normally Black																																																																																																																																																																																																													
White Luminance (Center)	[cd/m ²]	1500																																																																																																																																																																																																													
Contrast Ratio		5000:1																																																																																																																																																																																																													
Optical Response Time	[msec]	TBD																																																																																																																																																																																																													
Nominal Input Voltage VDD	[Volt]	+12.0 V																																																																																																																																																																																																													
Power Consumption	[Watt]	67.2 W (Cell: 4.8 + BL: 62.4) (Typ)@White																																																																																																																																																																																																													
ITEMS	Unit	SPECIFICATIONS																																																																																																																																																																																																													
Screen Diagonal	[mm]	600 (24.0")																																																																																																																																																																																																													
Active Area	[mm]	531.36 (H) x 298.89 (V)																																																																																																																																																																																																													
Pixels H x V		1920(x3) x 1080																																																																																																																																																																																																													
Pixel Pitch	[μm]	276.75 (per one triad) x 276.75																																																																																																																																																																																																													
Pixel Arrangement		R.G.B. Vertical Stripe																																																																																																																																																																																																													
Display Mode		VA Mode, Normally Black																																																																																																																																																																																																													
White Luminance (Center)	[cd/m ²]	1500																																																																																																																																																																																																													
Contrast Ratio		5000:1																																																																																																																																																																																																													
Optical Response Time	[msec]	25																																																																																																																																																																																																													
Nominal Input Voltage VDD	[Volt]	+12.0 V																																																																																																																																																																																																													
Power Consumption	[Watt]	69.8 W (Cell: 4.8 + BL: 65) (Typ)@White																																																																																																																																																																																																													
7	<p>2.2 Optical Characteristics ¹⁾</p> <p>The optical characteristics are measured under stable conditions at 25°C (Room Temperature): ¹⁾</p> <table border="1"> <thead> <tr> <th>Item</th> <th>Unit</th> <th>Conditions</th> <th>Min</th> <th>Typ</th> <th>Max</th> <th>Note</th> </tr> </thead> <tbody> <tr> <td>White Luminance</td> <td>[cd/m²]</td> <td>I_e = 91 mA</td> <td>1200</td> <td>1500</td> <td>1500</td> <td>1)</td> </tr> <tr> <td>Uniformity</td> <td>%</td> <td>9 Points</td> <td>75</td> <td>80</td> <td>80</td> <td>1, 2, 3)</td> </tr> <tr> <td>Contrast Ratio</td> <td></td> <td></td> <td>3000</td> <td>5000</td> <td>5000</td> <td>4)</td> </tr> <tr> <td>Cross talk</td> <td>%</td> <td></td> <td>1.5</td> <td>1.5</td> <td>1.5</td> <td>5)</td> </tr> <tr> <td rowspan="2">Response Time</td> <td rowspan="2">[msec]</td> <td>Rising</td> <td>16</td> <td>16</td> <td>16</td> <td>6)</td> </tr> <tr> <td>Falling</td> <td>9</td> <td>9</td> <td>9</td> <td>6)</td> </tr> <tr> <td rowspan="2">Viewing Angle</td> <td rowspan="2">[degree]</td> <td>Horizontal (Right)</td> <td>85</td> <td>85</td> <td>85</td> <td>7)</td> </tr> <tr> <td>Vertical (Upper)</td> <td>80</td> <td>80</td> <td>80</td> <td>7)</td> </tr> <tr> <td rowspan="7">Color / Chromaticity Coordinates (CIE 1931)</td> <td rowspan="7"></td> <td>Red x¹⁾</td> <td>0.602</td> <td>0.652</td> <td>0.702</td> <td></td> </tr> <tr> <td>Red y¹⁾</td> <td>0.285</td> <td>0.335</td> <td>0.385</td> <td></td> </tr> <tr> <td>Green x¹⁾</td> <td>0.271</td> <td>0.321</td> <td>0.371</td> <td></td> </tr> <tr> <td>Green y¹⁾</td> <td>0.568</td> <td>0.618</td> <td>0.668</td> <td></td> </tr> <tr> <td>Blue x¹⁾</td> <td>0.101</td> <td>0.151</td> <td>0.201</td> <td></td> </tr> <tr> <td>Blue y¹⁾</td> <td>0.059</td> <td>0.059</td> <td>0.109</td> <td></td> </tr> <tr> <td>White x¹⁾</td> <td>0.263</td> <td>0.313</td> <td>0.363</td> <td></td> </tr> <tr> <td>Color Gamut</td> <td>%</td> <td></td> <td>72</td> <td>72</td> <td></td> </tr> </tbody> </table>	Item	Unit	Conditions	Min	Typ	Max	Note	White Luminance	[cd/m ²]	I _e = 91 mA	1200	1500	1500	1)	Uniformity	%	9 Points	75	80	80	1, 2, 3)	Contrast Ratio			3000	5000	5000	4)	Cross talk	%		1.5	1.5	1.5	5)	Response Time	[msec]	Rising	16	16	16	6)	Falling	9	9	9	6)	Viewing Angle	[degree]	Horizontal (Right)	85	85	85	7)	Vertical (Upper)	80	80	80	7)	Color / Chromaticity Coordinates (CIE 1931)		Red x ¹⁾	0.602	0.652	0.702		Red y ¹⁾	0.285	0.335	0.385		Green x ¹⁾	0.271	0.321	0.371		Green y ¹⁾	0.568	0.618	0.668		Blue x ¹⁾	0.101	0.151	0.201		Blue y ¹⁾	0.059	0.059	0.109		White x ¹⁾	0.263	0.313	0.363		Color Gamut	%		72	72		<p>2.2 Optical Characteristics ¹⁾</p> <p>The optical characteristics are measured under stable conditions at 25°C (Room Temperature): ¹⁾</p> <table border="1"> <thead> <tr> <th>Item</th> <th>Unit</th> <th>Conditions</th> <th>Min</th> <th>Typ</th> <th>Max</th> <th>Note</th> </tr> </thead> <tbody> <tr> <td>White Luminance</td> <td>[cd/m²]</td> <td>I_e = 90mA</td> <td>1200</td> <td>1500</td> <td>1500</td> <td>1)</td> </tr> <tr> <td>Uniformity</td> <td>%</td> <td>9 Points</td> <td>75</td> <td>80</td> <td>80</td> <td>1, 2, 3)</td> </tr> <tr> <td>Contrast Ratio</td> <td></td> <td></td> <td>3000</td> <td>5000</td> <td>5000</td> <td>4)</td> </tr> <tr> <td>Cross talk</td> <td>%</td> <td></td> <td>1.5</td> <td>1.5</td> <td>1.5</td> <td>5)</td> </tr> <tr> <td rowspan="2">Response Time</td> <td rowspan="2">[msec]</td> <td>Rising</td> <td>16</td> <td>16</td> <td>16</td> <td>6)</td> </tr> <tr> <td>Falling</td> <td>9</td> <td>9</td> <td>9</td> <td>6)</td> </tr> <tr> <td rowspan="2">Viewing Angle</td> <td rowspan="2">[degree]</td> <td>Horizontal (Right)</td> <td>85</td> <td>85</td> <td>85</td> <td>7)</td> </tr> <tr> <td>Vertical (Upper)</td> <td>80</td> <td>80</td> <td>80</td> <td>7)</td> </tr> <tr> <td rowspan="7">Color / Chromaticity Coordinates (CIE 1931)</td> <td rowspan="7"></td> <td>Red x¹⁾</td> <td>0.602</td> <td>0.652</td> <td>0.702</td> <td></td> </tr> <tr> <td>Red y¹⁾</td> <td>0.285</td> <td>0.335</td> <td>0.385</td> <td></td> </tr> <tr> <td>Green x¹⁾</td> <td>0.271</td> <td>0.321</td> <td>0.371</td> <td></td> </tr> <tr> <td>Green y¹⁾</td> <td>0.568</td> <td>0.618</td> <td>0.668</td> <td></td> </tr> <tr> <td>Blue x¹⁾</td> <td>0.101</td> <td>0.151</td> <td>0.201</td> <td></td> </tr> <tr> <td>Blue y¹⁾</td> <td>0.059</td> <td>0.059</td> <td>0.109</td> <td></td> </tr> <tr> <td>White x¹⁾</td> <td>0.263</td> <td>0.313</td> <td>0.363</td> <td></td> </tr> <tr> <td>Color Gamut</td> <td>%</td> <td>NTSC</td> <td>72</td> <td>72</td> <td></td> </tr> </tbody> </table>	Item	Unit	Conditions	Min	Typ	Max	Note	White Luminance	[cd/m ²]	I _e = 90mA	1200	1500	1500	1)	Uniformity	%	9 Points	75	80	80	1, 2, 3)	Contrast Ratio			3000	5000	5000	4)	Cross talk	%		1.5	1.5	1.5	5)	Response Time	[msec]	Rising	16	16	16	6)	Falling	9	9	9	6)	Viewing Angle	[degree]	Horizontal (Right)	85	85	85	7)	Vertical (Upper)	80	80	80	7)	Color / Chromaticity Coordinates (CIE 1931)		Red x ¹⁾	0.602	0.652	0.702		Red y ¹⁾	0.285	0.335	0.385		Green x ¹⁾	0.271	0.321	0.371		Green y ¹⁾	0.568	0.618	0.668		Blue x ¹⁾	0.101	0.151	0.201		Blue y ¹⁾	0.059	0.059	0.109		White x ¹⁾	0.263	0.313	0.363		Color Gamut	%	NTSC	72	72		
Item	Unit	Conditions	Min	Typ	Max	Note																																																																																																																																																																																																									
White Luminance	[cd/m ²]	I _e = 91 mA	1200	1500	1500	1)																																																																																																																																																																																																									
Uniformity	%	9 Points	75	80	80	1, 2, 3)																																																																																																																																																																																																									
Contrast Ratio			3000	5000	5000	4)																																																																																																																																																																																																									
Cross talk	%		1.5	1.5	1.5	5)																																																																																																																																																																																																									
Response Time	[msec]	Rising	16	16	16	6)																																																																																																																																																																																																									
		Falling	9	9	9	6)																																																																																																																																																																																																									
Viewing Angle	[degree]	Horizontal (Right)	85	85	85	7)																																																																																																																																																																																																									
		Vertical (Upper)	80	80	80	7)																																																																																																																																																																																																									
Color / Chromaticity Coordinates (CIE 1931)		Red x ¹⁾	0.602	0.652	0.702																																																																																																																																																																																																										
		Red y ¹⁾	0.285	0.335	0.385																																																																																																																																																																																																										
		Green x ¹⁾	0.271	0.321	0.371																																																																																																																																																																																																										
		Green y ¹⁾	0.568	0.618	0.668																																																																																																																																																																																																										
		Blue x ¹⁾	0.101	0.151	0.201																																																																																																																																																																																																										
		Blue y ¹⁾	0.059	0.059	0.109																																																																																																																																																																																																										
		White x ¹⁾	0.263	0.313	0.363																																																																																																																																																																																																										
Color Gamut	%		72	72																																																																																																																																																																																																											
Item	Unit	Conditions	Min	Typ	Max	Note																																																																																																																																																																																																									
White Luminance	[cd/m ²]	I _e = 90mA	1200	1500	1500	1)																																																																																																																																																																																																									
Uniformity	%	9 Points	75	80	80	1, 2, 3)																																																																																																																																																																																																									
Contrast Ratio			3000	5000	5000	4)																																																																																																																																																																																																									
Cross talk	%		1.5	1.5	1.5	5)																																																																																																																																																																																																									
Response Time	[msec]	Rising	16	16	16	6)																																																																																																																																																																																																									
		Falling	9	9	9	6)																																																																																																																																																																																																									
Viewing Angle	[degree]	Horizontal (Right)	85	85	85	7)																																																																																																																																																																																																									
		Vertical (Upper)	80	80	80	7)																																																																																																																																																																																																									
Color / Chromaticity Coordinates (CIE 1931)		Red x ¹⁾	0.602	0.652	0.702																																																																																																																																																																																																										
		Red y ¹⁾	0.285	0.335	0.385																																																																																																																																																																																																										
		Green x ¹⁾	0.271	0.321	0.371																																																																																																																																																																																																										
		Green y ¹⁾	0.568	0.618	0.668																																																																																																																																																																																																										
		Blue x ¹⁾	0.101	0.151	0.201																																																																																																																																																																																																										
		Blue y ¹⁾	0.059	0.059	0.109																																																																																																																																																																																																										
		White x ¹⁾	0.263	0.313	0.363																																																																																																																																																																																																										
Color Gamut	%	NTSC	72	72																																																																																																																																																																																																											
14	<p>5.2 Backlight Unit ¹⁾</p> <p>5.2.1 LED Driver ¹⁾</p> <p>Following characteristics are measured under stable condition at 25°C (Room Temperature): ¹⁾</p> <table border="1"> <thead> <tr> <th>Symbol</th> <th>Parameter</th> <th>Min</th> <th>Typ</th> <th>Max</th> <th>Units</th> <th>Remark</th> </tr> </thead> <tbody> <tr> <td>V_{cc}</td> <td>Input Voltage</td> <td>23.5</td> <td>24</td> <td>24.5</td> <td>Volt</td> <td></td> </tr> <tr> <td>I_{cc}</td> <td>Input Current</td> <td>2.6</td> <td>3.12</td> <td>3.5</td> <td>A</td> <td>100% Dimming</td> </tr> <tr> <td>PLED</td> <td>Power Consumption</td> <td>62.4</td> <td>74.9</td> <td>87.4</td> <td>Watt</td> <td>100% Dimming</td> </tr> <tr> <td>I_{inrush}</td> <td>Inrush Current</td> <td>4</td> <td>5</td> <td>5</td> <td>A</td> <td></td> </tr> <tr> <td rowspan="2">BL_EN</td> <td>On Control Voltage</td> <td>3</td> <td>5</td> <td>5.5</td> <td>Volt</td> <td></td> </tr> <tr> <td>Off Control Voltage</td> <td>0</td> <td>0.5</td> <td>0.5</td> <td>Volt</td> <td></td> </tr> <tr> <td rowspan="2">FPWM</td> <td>PWM Dimming Frequency</td> <td>200</td> <td>200</td> <td>200</td> <td>Hz</td> <td></td> </tr> <tr> <td>High Voltage</td> <td>3.0</td> <td>3.3</td> <td>5.5</td> <td>Volt</td> <td></td> </tr> <tr> <td rowspan="3">LED</td> <td>Low Voltage</td> <td>0</td> <td>0.5</td> <td>0.5</td> <td>Volt</td> <td></td> </tr> <tr> <td>Dimming Duty 200Hz~5KHz</td> <td>5</td> <td>100</td> <td>100</td> <td>%</td> <td></td> </tr> <tr> <td>Dimming Duty 5KHz~20KHz</td> <td>15</td> <td>100</td> <td>100</td> <td>%</td> <td></td> </tr> <tr> <td>I_f</td> <td>LED Forward Current</td> <td>95</td> <td>95</td> <td>95</td> <td>mA</td> <td>T_a = 25°C</td> </tr> <tr> <td>LTLED</td> <td>LED Life Time</td> <td>50,000</td> <td></td> <td></td> <td>Hrs</td> <td>Note 4</td> </tr> </tbody> </table>	Symbol	Parameter	Min	Typ	Max	Units	Remark	V _{cc}	Input Voltage	23.5	24	24.5	Volt		I _{cc}	Input Current	2.6	3.12	3.5	A	100% Dimming	PLED	Power Consumption	62.4	74.9	87.4	Watt	100% Dimming	I _{inrush}	Inrush Current	4	5	5	A		BL_EN	On Control Voltage	3	5	5.5	Volt		Off Control Voltage	0	0.5	0.5	Volt		FPWM	PWM Dimming Frequency	200	200	200	Hz		High Voltage	3.0	3.3	5.5	Volt		LED	Low Voltage	0	0.5	0.5	Volt		Dimming Duty 200Hz~5KHz	5	100	100	%		Dimming Duty 5KHz~20KHz	15	100	100	%		I _f	LED Forward Current	95	95	95	mA	T _a = 25°C	LTLED	LED Life Time	50,000			Hrs	Note 4	<p>5.2 Backlight Unit ¹⁾</p> <p>5.2.1 LED Driver ¹⁾</p> <p>Following characteristics are measured under stable condition at 25°C (Room Temperature): ¹⁾</p> <table border="1"> <thead> <tr> <th>Symbol</th> <th>Parameter</th> <th>Min</th> <th>Typ</th> <th>Max</th> <th>Units</th> <th>Remark</th> </tr> </thead> <tbody> <tr> <td>V_{cc}</td> <td>Input Voltage</td> <td>23.5</td> <td>24</td> <td>24.5</td> <td>Volt</td> <td></td> </tr> <tr> <td>I_{cc}</td> <td>Input Current</td> <td>2.7</td> <td>3.25</td> <td>3.5</td> <td>A</td> <td>100% Dimming</td> </tr> <tr> <td>PLED</td> <td>Power Consumption</td> <td>65</td> <td>78</td> <td>87</td> <td>Watt</td> <td>100% Dimming</td> </tr> <tr> <td>I_{inrush}</td> <td>Inrush Current</td> <td>4</td> <td>5</td> <td>5</td> <td>A</td> <td></td> </tr> <tr> <td rowspan="2">BL_EN</td> <td>On Control Voltage</td> <td>3</td> <td>5</td> <td>5.5</td> <td>Volt</td> <td></td> </tr> <tr> <td>Off Control Voltage</td> <td>0</td> <td>0.5</td> <td>0.5</td> <td>Volt</td> <td></td> </tr> <tr> <td rowspan="2">FPWM</td> <td>PWM Dimming Frequency</td> <td>200</td> <td>200</td> <td>200</td> <td>Hz</td> <td></td> </tr> <tr> <td>High Voltage</td> <td>3.0</td> <td>3.3</td> <td>5.5</td> <td>Volt</td> <td></td> </tr> <tr> <td rowspan="3">LED</td> <td>Low Voltage</td> <td>0</td> <td>0.5</td> <td>0.5</td> <td>Volt</td> <td></td> </tr> <tr> <td>Dimming Duty 200Hz~5KHz</td> <td>5</td> <td>100</td> <td>100</td> <td>%</td> <td></td> </tr> <tr> <td>Dimming Duty 5KHz~20KHz</td> <td>15</td> <td>100</td> <td>100</td> <td>%</td> <td></td> </tr> <tr> <td>I_f</td> <td>LED Forward Current</td> <td>95</td> <td>95</td> <td>95</td> <td>mA</td> <td>T_a = 25°C</td> </tr> <tr> <td>LTLED</td> <td>LED Life Time</td> <td>50,000</td> <td></td> <td></td> <td>Hrs</td> <td>Note 4</td> </tr> </tbody> </table>	Symbol	Parameter	Min	Typ	Max	Units	Remark	V _{cc}	Input Voltage	23.5	24	24.5	Volt		I _{cc}	Input Current	2.7	3.25	3.5	A	100% Dimming	PLED	Power Consumption	65	78	87	Watt	100% Dimming	I _{inrush}	Inrush Current	4	5	5	A		BL_EN	On Control Voltage	3	5	5.5	Volt		Off Control Voltage	0	0.5	0.5	Volt		FPWM	PWM Dimming Frequency	200	200	200	Hz		High Voltage	3.0	3.3	5.5	Volt		LED	Low Voltage	0	0.5	0.5	Volt		Dimming Duty 200Hz~5KHz	5	100	100	%		Dimming Duty 5KHz~20KHz	15	100	100	%		I _f	LED Forward Current	95	95	95	mA	T _a = 25°C	LTLED	LED Life Time	50,000			Hrs	Note 4																	
Symbol	Parameter	Min	Typ	Max	Units	Remark																																																																																																																																																																																																									
V _{cc}	Input Voltage	23.5	24	24.5	Volt																																																																																																																																																																																																										
I _{cc}	Input Current	2.6	3.12	3.5	A	100% Dimming																																																																																																																																																																																																									
PLED	Power Consumption	62.4	74.9	87.4	Watt	100% Dimming																																																																																																																																																																																																									
I _{inrush}	Inrush Current	4	5	5	A																																																																																																																																																																																																										
BL_EN	On Control Voltage	3	5	5.5	Volt																																																																																																																																																																																																										
	Off Control Voltage	0	0.5	0.5	Volt																																																																																																																																																																																																										
FPWM	PWM Dimming Frequency	200	200	200	Hz																																																																																																																																																																																																										
	High Voltage	3.0	3.3	5.5	Volt																																																																																																																																																																																																										
LED	Low Voltage	0	0.5	0.5	Volt																																																																																																																																																																																																										
	Dimming Duty 200Hz~5KHz	5	100	100	%																																																																																																																																																																																																										
	Dimming Duty 5KHz~20KHz	15	100	100	%																																																																																																																																																																																																										
I _f	LED Forward Current	95	95	95	mA	T _a = 25°C																																																																																																																																																																																																									
LTLED	LED Life Time	50,000			Hrs	Note 4																																																																																																																																																																																																									
Symbol	Parameter	Min	Typ	Max	Units	Remark																																																																																																																																																																																																									
V _{cc}	Input Voltage	23.5	24	24.5	Volt																																																																																																																																																																																																										
I _{cc}	Input Current	2.7	3.25	3.5	A	100% Dimming																																																																																																																																																																																																									
PLED	Power Consumption	65	78	87	Watt	100% Dimming																																																																																																																																																																																																									
I _{inrush}	Inrush Current	4	5	5	A																																																																																																																																																																																																										
BL_EN	On Control Voltage	3	5	5.5	Volt																																																																																																																																																																																																										
	Off Control Voltage	0	0.5	0.5	Volt																																																																																																																																																																																																										
FPWM	PWM Dimming Frequency	200	200	200	Hz																																																																																																																																																																																																										
	High Voltage	3.0	3.3	5.5	Volt																																																																																																																																																																																																										
LED	Low Voltage	0	0.5	0.5	Volt																																																																																																																																																																																																										
	Dimming Duty 200Hz~5KHz	5	100	100	%																																																																																																																																																																																																										
	Dimming Duty 5KHz~20KHz	15	100	100	%																																																																																																																																																																																																										
I _f	LED Forward Current	95	95	95	mA	T _a = 25°C																																																																																																																																																																																																									
LTLED	LED Life Time	50,000			Hrs	Note 4																																																																																																																																																																																																									
0.5 2024/6/11	<p>5.2 Backlight Unit ¹⁾</p> <p>5.2.1 LED Driver ¹⁾</p> <p>Following characteristics are measured under stable condition at 25°C (Room Temperature): ¹⁾</p> <table border="1"> <thead> <tr> <th>Symbol</th> <th>Parameter</th> <th>Min</th> <th>Typ</th> <th>Max</th> <th>Units</th> <th>Remark</th> </tr> </thead> <tbody> <tr> <td>V_{cc}</td> <td>Input Voltage</td> <td>23.5</td> <td>24</td> <td>24.5</td> <td>Volt</td> <td></td> </tr> <tr> <td>I_{cc}</td> <td>Input Current</td> <td>2.7</td> <td>3.25</td> <td>3.5</td> <td>A</td> <td>100% Dimming</td> </tr> <tr> <td>PLED</td> <td>Power Consumption</td> <td>65</td> <td>78</td> <td>87</td> <td>Watt</td> <td>100% Dimming</td> </tr> </tbody> </table>	Symbol	Parameter	Min	Typ	Max	Units	Remark	V _{cc}	Input Voltage	23.5	24	24.5	Volt		I _{cc}	Input Current	2.7	3.25	3.5	A	100% Dimming	PLED	Power Consumption	65	78	87	Watt	100% Dimming	<p>5.2 Backlight Unit ¹⁾</p> <p>5.2.1 LED Driver ¹⁾</p> <p>Following characteristics are measured under stable condition at 25°C (Room Temperature): ¹⁾</p> <table border="1"> <thead> <tr> <th>Symbol</th> <th>Parameter</th> <th>Min</th> <th>Typ</th> <th>Max</th> <th>Units</th> <th>Remark</th> </tr> </thead> <tbody> <tr> <td>V_{cc}</td> <td>Input Voltage</td> <td>23.5</td> <td>24</td> <td>24.5</td> <td>Volt</td> <td></td> </tr> <tr> <td>I_{cc}</td> <td>Input Current</td> <td>2.7</td> <td>3.25</td> <td>3.5</td> <td>A</td> <td>100% Dimming</td> </tr> <tr> <td>PLED</td> <td>Power Consumption</td> <td>65</td> <td>78</td> <td>87</td> <td>Watt</td> <td>100% Dimming</td> </tr> </tbody> </table>	Symbol	Parameter	Min	Typ	Max	Units	Remark	V _{cc}	Input Voltage	23.5	24	24.5	Volt		I _{cc}	Input Current	2.7	3.25	3.5	A	100% Dimming	PLED	Power Consumption	65	78	87	Watt	100% Dimming																																																																																																																																																					
Symbol	Parameter	Min	Typ	Max	Units	Remark																																																																																																																																																																																																									
V _{cc}	Input Voltage	23.5	24	24.5	Volt																																																																																																																																																																																																										
I _{cc}	Input Current	2.7	3.25	3.5	A	100% Dimming																																																																																																																																																																																																									
PLED	Power Consumption	65	78	87	Watt	100% Dimming																																																																																																																																																																																																									
Symbol	Parameter	Min	Typ	Max	Units	Remark																																																																																																																																																																																																									
V _{cc}	Input Voltage	23.5	24	24.5	Volt																																																																																																																																																																																																										
I _{cc}	Input Current	2.7	3.25	3.5	A	100% Dimming																																																																																																																																																																																																									
PLED	Power Consumption	65	78	87	Watt	100% Dimming																																																																																																																																																																																																									

<p>0.6 2024/09/11</p>	<p>7</p>	<p>2.1 Display Characteristics¹⁾ The following items are characteristics summary on the table under 25 °C condition:²⁾</p> <table border="1"> <thead> <tr> <th>ITEMS³⁾</th> <th>Unit⁴⁾</th> <th>SPECIFICATIONS⁵⁾</th> </tr> </thead> <tbody> <tr> <td>Screen Diagonal⁶⁾</td> <td>[mm]</td> <td>609.7(24.0")</td> </tr> <tr> <td>Active Area⁷⁾</td> <td>[mm]</td> <td>531.36 (H) x 298.89 (V)⁸⁾</td> </tr> <tr> <td>Pixel Pitch⁹⁾</td> <td>[mm]</td> <td>1920(3) x 1080¹⁰⁾</td> </tr> <tr> <td>Pixel Pitch¹¹⁾</td> <td>[μm]</td> <td>276.75 (per one triad) x 276.75¹²⁾</td> </tr> <tr> <td>Pixel Arrangement¹³⁾</td> <td></td> <td>R.G.B. Vertical Stripe¹⁴⁾</td> </tr> <tr> <td>Display Mode¹⁵⁾</td> <td></td> <td>VA Mode, Normally Black¹⁶⁾</td> </tr> <tr> <td>White Luminance (Center)¹⁷⁾</td> <td>[cd/m²]</td> <td>1500¹⁸⁾</td> </tr> <tr> <td>Contrast Ratio¹⁹⁾</td> <td></td> <td>5000:1²⁰⁾</td> </tr> <tr> <td>Optical Response Time²¹⁾</td> <td>[msec]</td> <td>25²²⁾</td> </tr> <tr> <td>Nominal Input Voltage VDD²³⁾</td> <td>[Volt]</td> <td>+12.0 V²⁴⁾</td> </tr> <tr> <td>Power Consumption²⁵⁾</td> <td>[Watt]</td> <td>69.8 W (Cell: 4.8 x BL: 65) (Typ)@White²⁶⁾</td> </tr> <tr> <td>Weight²⁷⁾</td> <td>[g]</td> <td>2,050 (Typ.)±200 g²⁸⁾</td> </tr> <tr> <td>Physical Size²⁹⁾</td> <td>[mm]</td> <td>558.36(H) x 325.57(V) x 17.8 (D)Typ³⁰⁾</td> </tr> <tr> <td>Electrical Interface³¹⁾</td> <td></td> <td>Dual channel LVDS³²⁾</td> </tr> <tr> <td>Support Color³³⁾</td> <td></td> <td>16.7M colors (true 8-bit)³⁴⁾</td> </tr> <tr> <td>Surface Treatment³⁵⁾</td> <td></td> <td>Anti-Glare, 3H³⁶⁾</td> </tr> <tr> <td>Temperature Range³⁷⁾</td> <td>[°C]</td> <td>-30 to +80³⁸⁾</td> </tr> <tr> <td>Operating Storage (Shipping)³⁹⁾</td> <td>[°C]</td> <td>-30 to +80⁴⁰⁾</td> </tr> <tr> <td>RoHS Compliance⁴¹⁾</td> <td></td> <td>RoHS Compliance⁴²⁾</td> </tr> </tbody> </table>	ITEMS ³⁾	Unit ⁴⁾	SPECIFICATIONS ⁵⁾	Screen Diagonal ⁶⁾	[mm]	609.7(24.0")	Active Area ⁷⁾	[mm]	531.36 (H) x 298.89 (V) ⁸⁾	Pixel Pitch ⁹⁾	[mm]	1920(3) x 1080 ¹⁰⁾	Pixel Pitch ¹¹⁾	[μm]	276.75 (per one triad) x 276.75 ¹²⁾	Pixel Arrangement ¹³⁾		R.G.B. Vertical Stripe ¹⁴⁾	Display Mode ¹⁵⁾		VA Mode, Normally Black ¹⁶⁾	White Luminance (Center) ¹⁷⁾	[cd/m ²]	1500 ¹⁸⁾	Contrast Ratio ¹⁹⁾		5000:1 ²⁰⁾	Optical Response Time ²¹⁾	[msec]	25 ²²⁾	Nominal Input Voltage VDD ²³⁾	[Volt]	+12.0 V ²⁴⁾	Power Consumption ²⁵⁾	[Watt]	69.8 W (Cell: 4.8 x BL: 65) (Typ)@White ²⁶⁾	Weight ²⁷⁾	[g]	2,050 (Typ.)±200 g ²⁸⁾	Physical Size ²⁹⁾	[mm]	558.36(H) x 325.57(V) x 17.8 (D)Typ ³⁰⁾	Electrical Interface ³¹⁾		Dual channel LVDS ³²⁾	Support Color ³³⁾		16.7M colors (true 8-bit) ³⁴⁾	Surface Treatment ³⁵⁾		Anti-Glare, 3H ³⁶⁾	Temperature Range ³⁷⁾	[°C]	-30 to +80 ³⁸⁾	Operating Storage (Shipping) ³⁹⁾	[°C]	-30 to +80 ⁴⁰⁾	RoHS Compliance ⁴¹⁾		RoHS Compliance ⁴²⁾	<p>2.1 Display Characteristics¹⁾ The following items are characteristics summary on the table under 25 °C condition:²⁾</p> <table border="1"> <thead> <tr> <th>ITEMS³⁾</th> <th>Unit⁴⁾</th> <th>SPECIFICATIONS⁵⁾</th> </tr> </thead> <tbody> <tr> <td>Screen Diagonal⁶⁾</td> <td>[mm]</td> <td>609.7(24.0")</td> </tr> <tr> <td>Active Area⁷⁾</td> <td>[mm]</td> <td>531.36 (H) x 298.89 (V)⁸⁾</td> </tr> <tr> <td>Pixel Pitch⁹⁾</td> <td>[mm]</td> <td>1920(3) x 1080¹⁰⁾</td> </tr> <tr> <td>Pixel Pitch¹¹⁾</td> <td>[μm]</td> <td>276.75 (per one triad) x 276.75¹²⁾</td> </tr> <tr> <td>Pixel Arrangement¹³⁾</td> <td></td> <td>R.G.B. Vertical Stripe¹⁴⁾</td> </tr> <tr> <td>Display Mode¹⁵⁾</td> <td></td> <td>VA Mode, Normally Black¹⁶⁾</td> </tr> <tr> <td>White Luminance (Center)¹⁷⁾</td> <td>[cd/m²]</td> <td>1500¹⁸⁾</td> </tr> <tr> <td>Contrast Ratio¹⁹⁾</td> <td></td> <td>5000:1²⁰⁾</td> </tr> <tr> <td>Optical Response Time²¹⁾</td> <td>[msec]</td> <td>25²²⁾</td> </tr> <tr> <td>Nominal Input Voltage VDD²³⁾</td> <td>[Volt]</td> <td>+12.0 V²⁴⁾</td> </tr> <tr> <td>Power Consumption²⁵⁾</td> <td>[Watt]</td> <td>55.8 W (Cell: 4.8 x BL: 51) (Typ)@White²⁶⁾</td> </tr> <tr> <td>Weight²⁷⁾</td> <td>[g]</td> <td>2,050 (Typ.)±200 g²⁸⁾</td> </tr> <tr> <td>Physical Size²⁹⁾</td> <td>[mm]</td> <td>558.36(H) x 325.57(V) x 17.8 (D)Typ³⁰⁾</td> </tr> <tr> <td>Electrical Interface³¹⁾</td> <td></td> <td>Dual channel LVDS³²⁾</td> </tr> <tr> <td>Support Color³³⁾</td> <td></td> <td>16.7M colors (true 8-bit)³⁴⁾</td> </tr> <tr> <td>Surface Treatment³⁵⁾</td> <td></td> <td>Anti-Glare, 3H³⁶⁾</td> </tr> <tr> <td>Temperature Range³⁷⁾</td> <td>[°C]</td> <td>-30 to +80³⁸⁾</td> </tr> <tr> <td>Operating Storage (Shipping)³⁹⁾</td> <td>[°C]</td> <td>-30 to +80⁴⁰⁾</td> </tr> <tr> <td>RoHS Compliance⁴¹⁾</td> <td></td> <td>RoHS Compliance⁴²⁾</td> </tr> </tbody> </table>	ITEMS ³⁾	Unit ⁴⁾	SPECIFICATIONS ⁵⁾	Screen Diagonal ⁶⁾	[mm]	609.7(24.0")	Active Area ⁷⁾	[mm]	531.36 (H) x 298.89 (V) ⁸⁾	Pixel Pitch ⁹⁾	[mm]	1920(3) x 1080 ¹⁰⁾	Pixel Pitch ¹¹⁾	[μm]	276.75 (per one triad) x 276.75 ¹²⁾	Pixel Arrangement ¹³⁾		R.G.B. Vertical Stripe ¹⁴⁾	Display Mode ¹⁵⁾		VA Mode, Normally Black ¹⁶⁾	White Luminance (Center) ¹⁷⁾	[cd/m ²]	1500 ¹⁸⁾	Contrast Ratio ¹⁹⁾		5000:1 ²⁰⁾	Optical Response Time ²¹⁾	[msec]	25 ²²⁾	Nominal Input Voltage VDD ²³⁾	[Volt]	+12.0 V ²⁴⁾	Power Consumption ²⁵⁾	[Watt]	55.8 W (Cell: 4.8 x BL: 51) (Typ)@White ²⁶⁾	Weight ²⁷⁾	[g]	2,050 (Typ.)±200 g ²⁸⁾	Physical Size ²⁹⁾	[mm]	558.36(H) x 325.57(V) x 17.8 (D)Typ ³⁰⁾	Electrical Interface ³¹⁾		Dual channel LVDS ³²⁾	Support Color ³³⁾		16.7M colors (true 8-bit) ³⁴⁾	Surface Treatment ³⁵⁾		Anti-Glare, 3H ³⁶⁾	Temperature Range ³⁷⁾	[°C]	-30 to +80 ³⁸⁾	Operating Storage (Shipping) ³⁹⁾	[°C]	-30 to +80 ⁴⁰⁾	RoHS Compliance ⁴¹⁾		RoHS Compliance ⁴²⁾																																																																												
ITEMS ³⁾	Unit ⁴⁾	SPECIFICATIONS ⁵⁾																																																																																																																																																																																																					
Screen Diagonal ⁶⁾	[mm]	609.7(24.0")																																																																																																																																																																																																					
Active Area ⁷⁾	[mm]	531.36 (H) x 298.89 (V) ⁸⁾																																																																																																																																																																																																					
Pixel Pitch ⁹⁾	[mm]	1920(3) x 1080 ¹⁰⁾																																																																																																																																																																																																					
Pixel Pitch ¹¹⁾	[μm]	276.75 (per one triad) x 276.75 ¹²⁾																																																																																																																																																																																																					
Pixel Arrangement ¹³⁾		R.G.B. Vertical Stripe ¹⁴⁾																																																																																																																																																																																																					
Display Mode ¹⁵⁾		VA Mode, Normally Black ¹⁶⁾																																																																																																																																																																																																					
White Luminance (Center) ¹⁷⁾	[cd/m ²]	1500 ¹⁸⁾																																																																																																																																																																																																					
Contrast Ratio ¹⁹⁾		5000:1 ²⁰⁾																																																																																																																																																																																																					
Optical Response Time ²¹⁾	[msec]	25 ²²⁾																																																																																																																																																																																																					
Nominal Input Voltage VDD ²³⁾	[Volt]	+12.0 V ²⁴⁾																																																																																																																																																																																																					
Power Consumption ²⁵⁾	[Watt]	69.8 W (Cell: 4.8 x BL: 65) (Typ)@White ²⁶⁾																																																																																																																																																																																																					
Weight ²⁷⁾	[g]	2,050 (Typ.)±200 g ²⁸⁾																																																																																																																																																																																																					
Physical Size ²⁹⁾	[mm]	558.36(H) x 325.57(V) x 17.8 (D)Typ ³⁰⁾																																																																																																																																																																																																					
Electrical Interface ³¹⁾		Dual channel LVDS ³²⁾																																																																																																																																																																																																					
Support Color ³³⁾		16.7M colors (true 8-bit) ³⁴⁾																																																																																																																																																																																																					
Surface Treatment ³⁵⁾		Anti-Glare, 3H ³⁶⁾																																																																																																																																																																																																					
Temperature Range ³⁷⁾	[°C]	-30 to +80 ³⁸⁾																																																																																																																																																																																																					
Operating Storage (Shipping) ³⁹⁾	[°C]	-30 to +80 ⁴⁰⁾																																																																																																																																																																																																					
RoHS Compliance ⁴¹⁾		RoHS Compliance ⁴²⁾																																																																																																																																																																																																					
ITEMS ³⁾	Unit ⁴⁾	SPECIFICATIONS ⁵⁾																																																																																																																																																																																																					
Screen Diagonal ⁶⁾	[mm]	609.7(24.0")																																																																																																																																																																																																					
Active Area ⁷⁾	[mm]	531.36 (H) x 298.89 (V) ⁸⁾																																																																																																																																																																																																					
Pixel Pitch ⁹⁾	[mm]	1920(3) x 1080 ¹⁰⁾																																																																																																																																																																																																					
Pixel Pitch ¹¹⁾	[μm]	276.75 (per one triad) x 276.75 ¹²⁾																																																																																																																																																																																																					
Pixel Arrangement ¹³⁾		R.G.B. Vertical Stripe ¹⁴⁾																																																																																																																																																																																																					
Display Mode ¹⁵⁾		VA Mode, Normally Black ¹⁶⁾																																																																																																																																																																																																					
White Luminance (Center) ¹⁷⁾	[cd/m ²]	1500 ¹⁸⁾																																																																																																																																																																																																					
Contrast Ratio ¹⁹⁾		5000:1 ²⁰⁾																																																																																																																																																																																																					
Optical Response Time ²¹⁾	[msec]	25 ²²⁾																																																																																																																																																																																																					
Nominal Input Voltage VDD ²³⁾	[Volt]	+12.0 V ²⁴⁾																																																																																																																																																																																																					
Power Consumption ²⁵⁾	[Watt]	55.8 W (Cell: 4.8 x BL: 51) (Typ)@White ²⁶⁾																																																																																																																																																																																																					
Weight ²⁷⁾	[g]	2,050 (Typ.)±200 g ²⁸⁾																																																																																																																																																																																																					
Physical Size ²⁹⁾	[mm]	558.36(H) x 325.57(V) x 17.8 (D)Typ ³⁰⁾																																																																																																																																																																																																					
Electrical Interface ³¹⁾		Dual channel LVDS ³²⁾																																																																																																																																																																																																					
Support Color ³³⁾		16.7M colors (true 8-bit) ³⁴⁾																																																																																																																																																																																																					
Surface Treatment ³⁵⁾		Anti-Glare, 3H ³⁶⁾																																																																																																																																																																																																					
Temperature Range ³⁷⁾	[°C]	-30 to +80 ³⁸⁾																																																																																																																																																																																																					
Operating Storage (Shipping) ³⁹⁾	[°C]	-30 to +80 ⁴⁰⁾																																																																																																																																																																																																					
RoHS Compliance ⁴¹⁾		RoHS Compliance ⁴²⁾																																																																																																																																																																																																					
	<p>8</p>	<p>2.2 Optical Characteristics¹⁾ The optical characteristics are measured under stable conditions at 25°C (Room Temperature).²⁾</p> <table border="1"> <thead> <tr> <th>Item³⁾</th> <th>Unit⁴⁾</th> <th>Conditions⁵⁾</th> <th>Min.⁶⁾</th> <th>Typ.⁷⁾</th> <th>Max.⁸⁾</th> <th>Note⁹⁾</th> </tr> </thead> <tbody> <tr> <td>White Luminance¹⁰⁾</td> <td>[cd/m²]</td> <td>I_r = 85mA¹¹⁾</td> <td>1200¹²⁾</td> <td>1500¹³⁾</td> <td>—¹⁴⁾</td> <td>1¹⁵⁾</td> </tr> </tbody> </table>	Item ³⁾	Unit ⁴⁾	Conditions ⁵⁾	Min. ⁶⁾	Typ. ⁷⁾	Max. ⁸⁾	Note ⁹⁾	White Luminance ¹⁰⁾	[cd/m ²]	I _r = 85mA ¹¹⁾	1200 ¹²⁾	1500 ¹³⁾	— ¹⁴⁾	1 ¹⁵⁾	<p>2.2 Optical Characteristics¹⁾ The optical characteristics are measured under stable conditions at 25°C (Room Temperature).²⁾</p> <table border="1"> <thead> <tr> <th>Item³⁾</th> <th>Unit⁴⁾</th> <th>Conditions⁵⁾</th> <th>Min.⁶⁾</th> <th>Typ.⁷⁾</th> <th>Max.⁸⁾</th> <th>Note⁹⁾</th> </tr> </thead> <tbody> <tr> <td>White Luminance¹⁰⁾</td> <td>[cd/m²]</td> <td>I_r = 85mA¹¹⁾</td> <td>1200¹²⁾</td> <td>1500¹³⁾</td> <td>—¹⁴⁾</td> <td>1¹⁵⁾</td> </tr> </tbody> </table>	Item ³⁾	Unit ⁴⁾	Conditions ⁵⁾	Min. ⁶⁾	Typ. ⁷⁾	Max. ⁸⁾	Note ⁹⁾	White Luminance ¹⁰⁾	[cd/m ²]	I _r = 85mA ¹¹⁾	1200 ¹²⁾	1500 ¹³⁾	— ¹⁴⁾	1 ¹⁵⁾																																																																																																																																																																								
Item ³⁾	Unit ⁴⁾	Conditions ⁵⁾	Min. ⁶⁾	Typ. ⁷⁾	Max. ⁸⁾	Note ⁹⁾																																																																																																																																																																																																	
White Luminance ¹⁰⁾	[cd/m ²]	I _r = 85mA ¹¹⁾	1200 ¹²⁾	1500 ¹³⁾	— ¹⁴⁾	1 ¹⁵⁾																																																																																																																																																																																																	
Item ³⁾	Unit ⁴⁾	Conditions ⁵⁾	Min. ⁶⁾	Typ. ⁷⁾	Max. ⁸⁾	Note ⁹⁾																																																																																																																																																																																																	
White Luminance ¹⁰⁾	[cd/m ²]	I _r = 85mA ¹¹⁾	1200 ¹²⁾	1500 ¹³⁾	— ¹⁴⁾	1 ¹⁵⁾																																																																																																																																																																																																	
	<p>12</p>																																																																																																																																																																																																						
	<p>15</p>	<p>5.2 Backlight Unit¹⁾ 5.2.1 LED Driver²⁾ Following characteristics are measured under stable condition at 25°C (Room Temperature).³⁾</p> <table border="1"> <thead> <tr> <th>Symbol⁴⁾</th> <th>Parameter⁵⁾</th> <th>Min.⁶⁾</th> <th>Typ.⁷⁾</th> <th>Max.⁸⁾</th> <th>Units⁹⁾</th> <th>Remark¹⁰⁾</th> </tr> </thead> <tbody> <tr> <td>V_{CC}¹¹⁾</td> <td>Input Voltage¹²⁾</td> <td>23.5¹³⁾</td> <td>24¹⁴⁾</td> <td>24.5¹⁵⁾</td> <td>Volt¹⁶⁾</td> <td></td> </tr> <tr> <td>I_{CC}¹⁷⁾</td> <td>Input Current¹⁸⁾</td> <td>—¹⁹⁾</td> <td>2.36²⁰⁾</td> <td>2.83²¹⁾</td> <td>A²²⁾</td> <td>100% Dimming²³⁾</td> </tr> <tr> <td>P_{LED}²⁴⁾</td> <td>Power Consumption²⁵⁾</td> <td>—²⁶⁾</td> <td>56.6²⁷⁾</td> <td>68²⁸⁾</td> <td>Watt²⁹⁾</td> <td>100% Dimming³⁰⁾</td> </tr> <tr> <td>I_{inrush}³¹⁾</td> <td>Inrush Current³²⁾</td> <td>—³³⁾</td> <td>4³⁴⁾</td> <td>5³⁵⁾</td> <td>A³⁶⁾</td> <td></td> </tr> <tr> <td>BL_EN³⁷⁾</td> <td>On Control Voltage³⁸⁾</td> <td>3³⁹⁾</td> <td>—⁴⁰⁾</td> <td>5.5⁴¹⁾</td> <td>Volt⁴²⁾</td> <td></td> </tr> <tr> <td></td> <td>Off Control Voltage⁴³⁾</td> <td>0⁴⁴⁾</td> <td>—⁴⁵⁾</td> <td>0.5⁴⁶⁾</td> <td>Volt⁴⁷⁾</td> <td></td> </tr> <tr> <td></td> <td>PWM Dimming Frequency⁴⁸⁾</td> <td>200⁴⁹⁾</td> <td>—⁵⁰⁾</td> <td>20K⁵¹⁾</td> <td>Hz⁵²⁾</td> <td></td> </tr> <tr> <td></td> <td>High Voltage⁵³⁾</td> <td>3.0⁵⁴⁾</td> <td>3.3⁵⁵⁾</td> <td>5.5⁵⁶⁾</td> <td>Volt⁵⁷⁾</td> <td></td> </tr> <tr> <td></td> <td>Low Voltage⁵⁸⁾</td> <td>0⁵⁹⁾</td> <td>—⁶⁰⁾</td> <td>0.5⁶¹⁾</td> <td>Volt⁶²⁾</td> <td></td> </tr> <tr> <td></td> <td>Dimming Duty 200Hz-9KHz⁶³⁾</td> <td>5⁶⁴⁾</td> <td>—⁶⁵⁾</td> <td>100⁶⁶⁾</td> <td>%⁶⁷⁾</td> <td></td> </tr> <tr> <td></td> <td>Dimming Duty 9KHz-20KHz⁶⁸⁾</td> <td>15⁶⁹⁾</td> <td>—⁷⁰⁾</td> <td>100⁷¹⁾</td> <td>%⁷²⁾</td> <td></td> </tr> <tr> <td>I_r⁷³⁾</td> <td>LED Forward Current⁷⁴⁾</td> <td>—⁷⁵⁾</td> <td>95⁷⁶⁾</td> <td>—⁷⁷⁾</td> <td>mA⁷⁸⁾</td> <td>T_a = 25°C⁷⁹⁾</td> </tr> <tr> <td>LTLED⁸⁰⁾</td> <td>LED Life Time⁸¹⁾</td> <td>—⁸²⁾</td> <td>50,000⁸³⁾</td> <td>—⁸⁴⁾</td> <td>Hrs⁸⁵⁾</td> <td>Note 4⁸⁶⁾</td> </tr> </tbody> </table> <p>Note 1: T_a means ambient temperature of TFT-LCD module. Note 2: If module is driven by high current or at high ambient temperature & humidity condition. The operating life will be reduced. Note 3: LED light bar structure: (7 strings x 12pcs / string -84pcs LED) Note 4: Definition of life time: Brightness becomes to 50% of its original value. The minimum life time of LED unit is on the condition of I_r = 95 mA and 25±2°C (Room Temperature).</p>	Symbol ⁴⁾	Parameter ⁵⁾	Min. ⁶⁾	Typ. ⁷⁾	Max. ⁸⁾	Units ⁹⁾	Remark ¹⁰⁾	V _{CC} ¹¹⁾	Input Voltage ¹²⁾	23.5 ¹³⁾	24 ¹⁴⁾	24.5 ¹⁵⁾	Volt ¹⁶⁾		I _{CC} ¹⁷⁾	Input Current ¹⁸⁾	— ¹⁹⁾	2.36 ²⁰⁾	2.83 ²¹⁾	A ²²⁾	100% Dimming ²³⁾	P _{LED} ²⁴⁾	Power Consumption ²⁵⁾	— ²⁶⁾	56.6 ²⁷⁾	68 ²⁸⁾	Watt ²⁹⁾	100% Dimming ³⁰⁾	I _{inrush} ³¹⁾	Inrush Current ³²⁾	— ³³⁾	4 ³⁴⁾	5 ³⁵⁾	A ³⁶⁾		BL_EN ³⁷⁾	On Control Voltage ³⁸⁾	3 ³⁹⁾	— ⁴⁰⁾	5.5 ⁴¹⁾	Volt ⁴²⁾			Off Control Voltage ⁴³⁾	0 ⁴⁴⁾	— ⁴⁵⁾	0.5 ⁴⁶⁾	Volt ⁴⁷⁾			PWM Dimming Frequency ⁴⁸⁾	200 ⁴⁹⁾	— ⁵⁰⁾	20K ⁵¹⁾	Hz ⁵²⁾			High Voltage ⁵³⁾	3.0 ⁵⁴⁾	3.3 ⁵⁵⁾	5.5 ⁵⁶⁾	Volt ⁵⁷⁾			Low Voltage ⁵⁸⁾	0 ⁵⁹⁾	— ⁶⁰⁾	0.5 ⁶¹⁾	Volt ⁶²⁾			Dimming Duty 200Hz-9KHz ⁶³⁾	5 ⁶⁴⁾	— ⁶⁵⁾	100 ⁶⁶⁾	% ⁶⁷⁾			Dimming Duty 9KHz-20KHz ⁶⁸⁾	15 ⁶⁹⁾	— ⁷⁰⁾	100 ⁷¹⁾	% ⁷²⁾		I _r ⁷³⁾	LED Forward Current ⁷⁴⁾	— ⁷⁵⁾	95 ⁷⁶⁾	— ⁷⁷⁾	mA ⁷⁸⁾	T _a = 25°C ⁷⁹⁾	LTLED ⁸⁰⁾	LED Life Time ⁸¹⁾	— ⁸²⁾	50,000 ⁸³⁾	— ⁸⁴⁾	Hrs ⁸⁵⁾	Note 4 ⁸⁶⁾	<p>5.2 Backlight Unit¹⁾ 5.2.1 LED Driver²⁾ Following characteristics are measured under stable condition at 25°C (Room Temperature).³⁾</p> <table border="1"> <thead> <tr> <th>Symbol⁴⁾</th> <th>Parameter⁵⁾</th> <th>Min.⁶⁾</th> <th>Typ.⁷⁾</th> <th>Max.⁸⁾</th> <th>Units⁹⁾</th> <th>Remark¹⁰⁾</th> </tr> </thead> <tbody> <tr> <td>V_{CC}¹¹⁾</td> <td>Input Voltage¹²⁾</td> <td>23.5¹³⁾</td> <td>24¹⁴⁾</td> <td>24.5¹⁵⁾</td> <td>Volt¹⁶⁾</td> <td></td> </tr> <tr> <td>I_{CC}¹⁷⁾</td> <td>Input Current¹⁸⁾</td> <td>—¹⁹⁾</td> <td>2.13²⁰⁾</td> <td>2.55²¹⁾</td> <td>A²²⁾</td> <td>100% Dimming²³⁾</td> </tr> <tr> <td>P_{LED}²⁴⁾</td> <td>Power Consumption²⁵⁾</td> <td>—²⁶⁾</td> <td>51²⁷⁾</td> <td>61.2²⁸⁾</td> <td>Watt²⁹⁾</td> <td>100% Dimming³⁰⁾</td> </tr> <tr> <td>I_{inrush}³¹⁾</td> <td>Inrush Current³²⁾</td> <td>—³³⁾</td> <td>4³⁴⁾</td> <td>5³⁵⁾</td> <td>A³⁶⁾</td> <td></td> </tr> <tr> <td>BL_EN³⁷⁾</td> <td>On Control Voltage³⁸⁾</td> <td>3³⁹⁾</td> <td>—⁴⁰⁾</td> <td>5.5⁴¹⁾</td> <td>Volt⁴²⁾</td> <td></td> </tr> <tr> <td></td> <td>Off Control Voltage⁴³⁾</td> <td>0⁴⁴⁾</td> <td>—⁴⁵⁾</td> <td>0.5⁴⁶⁾</td> <td>Volt⁴⁷⁾</td> <td></td> </tr> <tr> <td></td> <td>PWM Dimming Frequency⁴⁸⁾</td> <td>200⁴⁹⁾</td> <td>—⁵⁰⁾</td> <td>20K⁵¹⁾</td> <td>Hz⁵²⁾</td> <td></td> </tr> <tr> <td></td> <td>High Voltage⁵³⁾</td> <td>3.0⁵⁴⁾</td> <td>3.3⁵⁵⁾</td> <td>5.5⁵⁶⁾</td> <td>Volt⁵⁷⁾</td> <td></td> </tr> <tr> <td></td> <td>Low Voltage⁵⁸⁾</td> <td>0⁵⁹⁾</td> <td>—⁶⁰⁾</td> <td>0.5⁶¹⁾</td> <td>Volt⁶²⁾</td> <td></td> </tr> <tr> <td></td> <td>Dimming Duty 200Hz-9KHz⁶³⁾</td> <td>5⁶⁴⁾</td> <td>—⁶⁵⁾</td> <td>100⁶⁶⁾</td> <td>%⁶⁷⁾</td> <td></td> </tr> <tr> <td></td> <td>Dimming Duty 9KHz-20KHz⁶⁸⁾</td> <td>15⁶⁹⁾</td> <td>—⁷⁰⁾</td> <td>100⁷¹⁾</td> <td>%⁷²⁾</td> <td></td> </tr> <tr> <td>I_r⁷³⁾</td> <td>LED Forward Current⁷⁴⁾</td> <td>—⁷⁵⁾</td> <td>85⁷⁶⁾</td> <td>—⁷⁷⁾</td> <td>mA⁷⁸⁾</td> <td>T_a = 25°C⁷⁹⁾</td> </tr> <tr> <td>LTLED⁸⁰⁾</td> <td>LED Life Time⁸¹⁾</td> <td>—⁸²⁾</td> <td>50,000⁸³⁾</td> <td>—⁸⁴⁾</td> <td>Hrs⁸⁵⁾</td> <td>Note 4⁸⁶⁾</td> </tr> </tbody> </table> <p>Note 1: T_a means ambient temperature of TFT-LCD module. Note 2: If module is driven by high current or at high ambient temperature & humidity condition. The operating life will be reduced. Note 3: LED light bar structure: (7 strings x 12pcs / string -84pcs LED) Note 4: Definition of life time: Brightness becomes to 50% of its original value. The minimum life time of LED unit is on the condition of I_r = 85 mA and 25±2°C (Room Temperature).</p>	Symbol ⁴⁾	Parameter ⁵⁾	Min. ⁶⁾	Typ. ⁷⁾	Max. ⁸⁾	Units ⁹⁾	Remark ¹⁰⁾	V _{CC} ¹¹⁾	Input Voltage ¹²⁾	23.5 ¹³⁾	24 ¹⁴⁾	24.5 ¹⁵⁾	Volt ¹⁶⁾		I _{CC} ¹⁷⁾	Input Current ¹⁸⁾	— ¹⁹⁾	2.13 ²⁰⁾	2.55 ²¹⁾	A ²²⁾	100% Dimming ²³⁾	P _{LED} ²⁴⁾	Power Consumption ²⁵⁾	— ²⁶⁾	51 ²⁷⁾	61.2 ²⁸⁾	Watt ²⁹⁾	100% Dimming ³⁰⁾	I _{inrush} ³¹⁾	Inrush Current ³²⁾	— ³³⁾	4 ³⁴⁾	5 ³⁵⁾	A ³⁶⁾		BL_EN ³⁷⁾	On Control Voltage ³⁸⁾	3 ³⁹⁾	— ⁴⁰⁾	5.5 ⁴¹⁾	Volt ⁴²⁾			Off Control Voltage ⁴³⁾	0 ⁴⁴⁾	— ⁴⁵⁾	0.5 ⁴⁶⁾	Volt ⁴⁷⁾			PWM Dimming Frequency ⁴⁸⁾	200 ⁴⁹⁾	— ⁵⁰⁾	20K ⁵¹⁾	Hz ⁵²⁾			High Voltage ⁵³⁾	3.0 ⁵⁴⁾	3.3 ⁵⁵⁾	5.5 ⁵⁶⁾	Volt ⁵⁷⁾			Low Voltage ⁵⁸⁾	0 ⁵⁹⁾	— ⁶⁰⁾	0.5 ⁶¹⁾	Volt ⁶²⁾			Dimming Duty 200Hz-9KHz ⁶³⁾	5 ⁶⁴⁾	— ⁶⁵⁾	100 ⁶⁶⁾	% ⁶⁷⁾			Dimming Duty 9KHz-20KHz ⁶⁸⁾	15 ⁶⁹⁾	— ⁷⁰⁾	100 ⁷¹⁾	% ⁷²⁾		I _r ⁷³⁾	LED Forward Current ⁷⁴⁾	— ⁷⁵⁾	85 ⁷⁶⁾	— ⁷⁷⁾	mA ⁷⁸⁾	T _a = 25°C ⁷⁹⁾	LTLED ⁸⁰⁾	LED Life Time ⁸¹⁾	— ⁸²⁾	50,000 ⁸³⁾	— ⁸⁴⁾	Hrs ⁸⁵⁾	Note 4 ⁸⁶⁾
Symbol ⁴⁾	Parameter ⁵⁾	Min. ⁶⁾	Typ. ⁷⁾	Max. ⁸⁾	Units ⁹⁾	Remark ¹⁰⁾																																																																																																																																																																																																	
V _{CC} ¹¹⁾	Input Voltage ¹²⁾	23.5 ¹³⁾	24 ¹⁴⁾	24.5 ¹⁵⁾	Volt ¹⁶⁾																																																																																																																																																																																																		
I _{CC} ¹⁷⁾	Input Current ¹⁸⁾	— ¹⁹⁾	2.36 ²⁰⁾	2.83 ²¹⁾	A ²²⁾	100% Dimming ²³⁾																																																																																																																																																																																																	
P _{LED} ²⁴⁾	Power Consumption ²⁵⁾	— ²⁶⁾	56.6 ²⁷⁾	68 ²⁸⁾	Watt ²⁹⁾	100% Dimming ³⁰⁾																																																																																																																																																																																																	
I _{inrush} ³¹⁾	Inrush Current ³²⁾	— ³³⁾	4 ³⁴⁾	5 ³⁵⁾	A ³⁶⁾																																																																																																																																																																																																		
BL_EN ³⁷⁾	On Control Voltage ³⁸⁾	3 ³⁹⁾	— ⁴⁰⁾	5.5 ⁴¹⁾	Volt ⁴²⁾																																																																																																																																																																																																		
	Off Control Voltage ⁴³⁾	0 ⁴⁴⁾	— ⁴⁵⁾	0.5 ⁴⁶⁾	Volt ⁴⁷⁾																																																																																																																																																																																																		
	PWM Dimming Frequency ⁴⁸⁾	200 ⁴⁹⁾	— ⁵⁰⁾	20K ⁵¹⁾	Hz ⁵²⁾																																																																																																																																																																																																		
	High Voltage ⁵³⁾	3.0 ⁵⁴⁾	3.3 ⁵⁵⁾	5.5 ⁵⁶⁾	Volt ⁵⁷⁾																																																																																																																																																																																																		
	Low Voltage ⁵⁸⁾	0 ⁵⁹⁾	— ⁶⁰⁾	0.5 ⁶¹⁾	Volt ⁶²⁾																																																																																																																																																																																																		
	Dimming Duty 200Hz-9KHz ⁶³⁾	5 ⁶⁴⁾	— ⁶⁵⁾	100 ⁶⁶⁾	% ⁶⁷⁾																																																																																																																																																																																																		
	Dimming Duty 9KHz-20KHz ⁶⁸⁾	15 ⁶⁹⁾	— ⁷⁰⁾	100 ⁷¹⁾	% ⁷²⁾																																																																																																																																																																																																		
I _r ⁷³⁾	LED Forward Current ⁷⁴⁾	— ⁷⁵⁾	95 ⁷⁶⁾	— ⁷⁷⁾	mA ⁷⁸⁾	T _a = 25°C ⁷⁹⁾																																																																																																																																																																																																	
LTLED ⁸⁰⁾	LED Life Time ⁸¹⁾	— ⁸²⁾	50,000 ⁸³⁾	— ⁸⁴⁾	Hrs ⁸⁵⁾	Note 4 ⁸⁶⁾																																																																																																																																																																																																	
Symbol ⁴⁾	Parameter ⁵⁾	Min. ⁶⁾	Typ. ⁷⁾	Max. ⁸⁾	Units ⁹⁾	Remark ¹⁰⁾																																																																																																																																																																																																	
V _{CC} ¹¹⁾	Input Voltage ¹²⁾	23.5 ¹³⁾	24 ¹⁴⁾	24.5 ¹⁵⁾	Volt ¹⁶⁾																																																																																																																																																																																																		
I _{CC} ¹⁷⁾	Input Current ¹⁸⁾	— ¹⁹⁾	2.13 ²⁰⁾	2.55 ²¹⁾	A ²²⁾	100% Dimming ²³⁾																																																																																																																																																																																																	
P _{LED} ²⁴⁾	Power Consumption ²⁵⁾	— ²⁶⁾	51 ²⁷⁾	61.2 ²⁸⁾	Watt ²⁹⁾	100% Dimming ³⁰⁾																																																																																																																																																																																																	
I _{inrush} ³¹⁾	Inrush Current ³²⁾	— ³³⁾	4 ³⁴⁾	5 ³⁵⁾	A ³⁶⁾																																																																																																																																																																																																		
BL_EN ³⁷⁾	On Control Voltage ³⁸⁾	3 ³⁹⁾	— ⁴⁰⁾	5.5 ⁴¹⁾	Volt ⁴²⁾																																																																																																																																																																																																		
	Off Control Voltage ⁴³⁾	0 ⁴⁴⁾	— ⁴⁵⁾	0.5 ⁴⁶⁾	Volt ⁴⁷⁾																																																																																																																																																																																																		
	PWM Dimming Frequency ⁴⁸⁾	200 ⁴⁹⁾	— ⁵⁰⁾	20K ⁵¹⁾	Hz ⁵²⁾																																																																																																																																																																																																		
	High Voltage ⁵³⁾	3.0 ⁵⁴⁾	3.3 ⁵⁵⁾	5.5 ⁵⁶⁾	Volt ⁵⁷⁾																																																																																																																																																																																																		
	Low Voltage ⁵⁸⁾	0 ⁵⁹⁾	— ⁶⁰⁾	0.5 ⁶¹⁾	Volt ⁶²⁾																																																																																																																																																																																																		
	Dimming Duty 200Hz-9KHz ⁶³⁾	5 ⁶⁴⁾	— ⁶⁵⁾	100 ⁶⁶⁾	% ⁶⁷⁾																																																																																																																																																																																																		
	Dimming Duty 9KHz-20KHz ⁶⁸⁾	15 ⁶⁹⁾	— ⁷⁰⁾	100 ⁷¹⁾	% ⁷²⁾																																																																																																																																																																																																		
I _r ⁷³⁾	LED Forward Current ⁷⁴⁾	— ⁷⁵⁾	85 ⁷⁶⁾	— ⁷⁷⁾	mA ⁷⁸⁾	T _a = 25°C ⁷⁹⁾																																																																																																																																																																																																	
LTLED ⁸⁰⁾	LED Life Time ⁸¹⁾	— ⁸²⁾	50,000 ⁸³⁾	— ⁸⁴⁾	Hrs ⁸⁵⁾	Note 4 ⁸⁶⁾																																																																																																																																																																																																	
	<p>21</p>	<p>7.2 Backlight Unit: LED Connector¹⁾</p> <table border="1"> <thead> <tr> <th>Connector Name / Designation²⁾</th> <th>LED Connector³⁾</th> </tr> </thead> <tbody> <tr> <td>Manufacturer⁴⁾</td> <td>JST⁵⁾</td> </tr> <tr> <td>Connector Model Number⁶⁾</td> <td>S14B-PH-SMS-K-TB(HF)⁷⁾</td> </tr> <tr> <td>Mating Housing Part Number⁸⁾</td> <td>PHR-14 or compatible⁹⁾</td> </tr> </tbody> </table>	Connector Name / Designation ²⁾	LED Connector ³⁾	Manufacturer ⁴⁾	JST ⁵⁾	Connector Model Number ⁶⁾	S14B-PH-SMS-K-TB(HF) ⁷⁾	Mating Housing Part Number ⁸⁾	PHR-14 or compatible ⁹⁾	<p>7.2 Backlight Unit: LED Connector¹⁾</p> <table border="1"> <thead> <tr> <th>Connector Name / Designation²⁾</th> <th>LED Connector³⁾</th> </tr> </thead> <tbody> <tr> <td>Manufacturer⁴⁾</td> <td>Omron⁵⁾</td> </tr> <tr> <td>Connector Model Number⁶⁾</td> <td>CD114M1HRO-NH⁷⁾</td> </tr> <tr> <td>Mating Housing Part Number⁸⁾</td> <td>PHR-14 or compatible⁹⁾</td> </tr> </tbody> </table>	Connector Name / Designation ²⁾	LED Connector ³⁾	Manufacturer ⁴⁾	Omron ⁵⁾	Connector Model Number ⁶⁾	CD114M1HRO-NH ⁷⁾	Mating Housing Part Number ⁸⁾	PHR-14 or compatible ⁹⁾																																																																																																																																																																																				
Connector Name / Designation ²⁾	LED Connector ³⁾																																																																																																																																																																																																						
Manufacturer ⁴⁾	JST ⁵⁾																																																																																																																																																																																																						
Connector Model Number ⁶⁾	S14B-PH-SMS-K-TB(HF) ⁷⁾																																																																																																																																																																																																						
Mating Housing Part Number ⁸⁾	PHR-14 or compatible ⁹⁾																																																																																																																																																																																																						
Connector Name / Designation ²⁾	LED Connector ³⁾																																																																																																																																																																																																						
Manufacturer ⁴⁾	Omron ⁵⁾																																																																																																																																																																																																						
Connector Model Number ⁶⁾	CD114M1HRO-NH ⁷⁾																																																																																																																																																																																																						
Mating Housing Part Number ⁸⁾	PHR-14 or compatible ⁹⁾																																																																																																																																																																																																						
<p>1.0 2024/12/10</p>	<p>all</p>	<p>Preliminary Specification</p>	<p>Final Specification</p>																																																																																																																																																																																																				

1. Operating Precautions

- 1) Since front polarizer is easily damaged, pay attention not to scratch it.
- 2) Be sure to turn off power supply when inserting or disconnecting from input connector.
- 3) Wipe off water drop immediately. Long contact with water may cause discoloration or spots.
- 4) When the panel surface is soiled, wipe it with absorbent cotton or other soft cloth.
- 5) Since the panel is made of glass, it may break or crack if dropped or bumped on hard surface.
- 6) Since CMOS LSI is used in this module, take care of static electricity and insure human earth when handling.
- 7) Do not open or modify the Module Assembly.
- 8) In case if a Module has to be put back into the packing container slot after once it was taken out from the container, take it easily, or the TFT Module may be damaged.
- 9) At the insertion or removal of the Signal Interface Connector, be sure not to rotate nor tilt the Interface Connector of the TFT Module.
- 10) After installation of the TFT Module into an enclosure, do not twist nor bend the TFT Module even momentary. At designing the enclosure, it should be taken into consideration that no bending/twisting forces are applied to the TFT Module from outside. Otherwise the TFT Module may be damaged.
- 11) Small amount of materials having no flammability grade is used in the LCD module. The LCD module should be supplied by power complied with requirements of Limited Power Source (IEC60950 or UL1950), or be applied exemption.
- 12) Severe temperature condition may result in different luminance, response time and LED life time.
- 13) The data on this specification sheet is applicable when LCD module is placed in landscape position.
- 14) Continuous displaying fixed pattern may induce image sticking. It is recommended to use screen saver or shuffle content periodically if fixed pattern is displayed on the screen.

2. General Description

This specification applies to the 24 inch-wide Color TFT-LCD Module G240HVN01.0. The display supports the Full HD - 1920(H) x 1080(V) screen format and 16.7M colors (RGB 8-bits data). All input signals are dual channel LVDS interface.

LED driver board is included. G240HVN01.0 is designed for industrial display applications.

2.1 Display Characteristics

The following items are characteristics summary on the table under 25 °C condition:

ITEMS	Unit	SPECIFICATIONS
Screen Diagonal	[mm]	609.7(24.0")
Active Area	[mm]	531.36 (H) x 298.89 (V)
Pixels H x V		1920(x3) x 1080
Pixel Pitch	[um]	276.75 (per one triad) x276.75
Pixel Arrangement		R.G.B. Vertical Stripe
Display Mode		VA Mode, Normally Black
White Luminance (Center)	[cd/m ²]	1500
Contrast Ratio		5000: 1
Optical Response Time	[msec]	25
Nominal Input Voltage VDD	[Volt]	+12.0 V
Power Consumption	[Watt]	55.8 W (Cell: 4.8 + BL: 51) (Typ)@White
Weight	[g]	2,050 (Typ.)+/-200 g
Physical Size	[mm]	558.36(H) x 325.57(V) x 17.8 (D)Typ
Electrical Interface		Dual channel LVDS
Support Color		16.7M colors (true 8-bit)
Surface Treatment		Anti-Glare, 3H
Temperature Range		
Operating	[°C]	-30 to +80
Storage (Shipping)	[°C]	-30 to +80
RoHS Compliance		RoHS Compliance

2.2 Optical Characteristics

The optical characteristics are measured under stable conditions at 25°C (Room Temperature):

Item	Unit	Conditions	Min.	Typ.	Max.	Note
White Luminance	[cd/m ²]	I _F = 85mA	1200	1500	-	1
Uniformity	%	9 Points	75	80	-	1, 2, 3
Contrast Ratio			3000	5000	-	4
Cross talk	%		-	-	1.5	5
Response Time	[msec]	Rising	-	16		6
		Falling	-	9		
		Rising + Falling	-	25	50	
Viewing Angle	[degree]	Horizontal (Right) CR = 10 (Left)		85	-	7
	[degree]			85	-	
	[degree]	Vertical (Upper) CR = 10 (Lower)		80	-	
	[degree]			80	-	
Color / Chromaticity Coordinates (CIE 1931)		Red x	0.602	0.652	0.702	
		Red y	0.285	0.335	0.385	
		Green x	0.271	0.321	0.371	
		Green y	0.568	0.618	0.668	
		Blue x	0.101	0.151	0.201	
		Blue y	0.009	0.059	0.109	
		White x	0.263	0.313	0.363	
		White y	0.279	0.329	0.379	
Color Gamut	%	NTSC		72	-	

Note 1: Measurement method

Equipment Pattern Generator, Power Supply, Digital Voltmeter, Luminance meter (SR_3 or equivalent)

Aperture 1 with 50cm viewing distance

Test Point Center

Environment < 1 lux

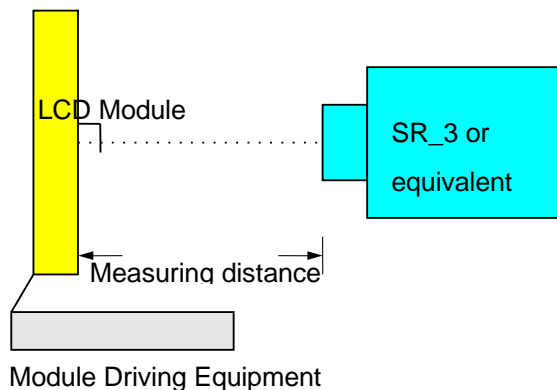

Note 2: Definition of 9 points position. Display active area:

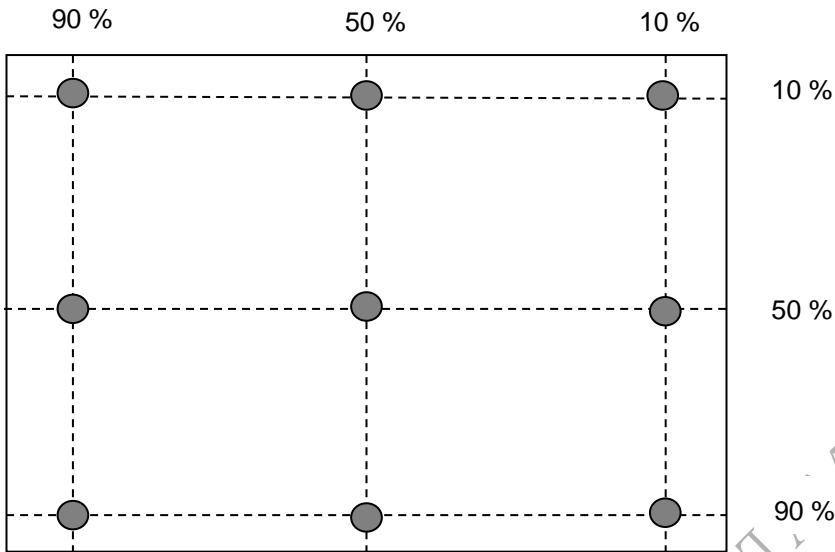

Note 3: The luminance uniformity of 9 points is defined by dividing the minimum luminance values by the maximum test point luminance

$$\delta_{w9} = \frac{\text{Minimum Brightness of nine points}}{\text{Maximum Brightness of nine points}}$$

Note 4 : Definition of contrast ratio (CR):

$$\text{Contrast ratio (CR)} = \frac{\text{Brightness on the "White" state}}{\text{Brightness on the "Black" state}}$$

Note 5 : Definition of cross talk (CT)

$$CT = | YB - YA | / YA \times 100 (\%)$$

Where

YA = Luminance of measured location without gray level 255 pattern (cd/m2)

YB = Luminance of measured location with gray level 255 pattern (cd/m2)

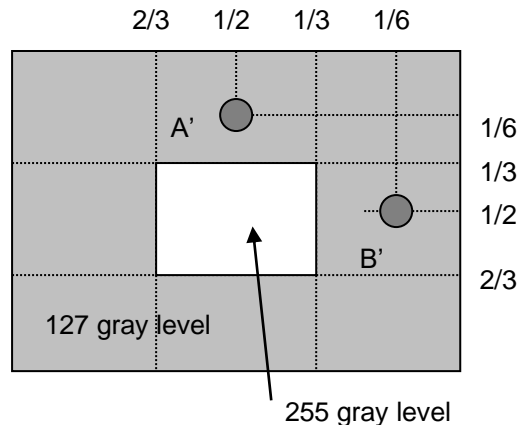
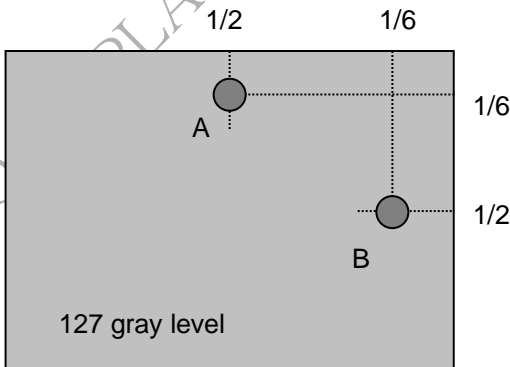

Note 6: Definition of response time:

The output signals of photo detector are measured when the input signals are changed from “White” to “Black” (falling time) and from “Black” to “White” (rising time), respectively. The response time interval is between 10% and 90% of amplitudes. Please refer to the figure as below.

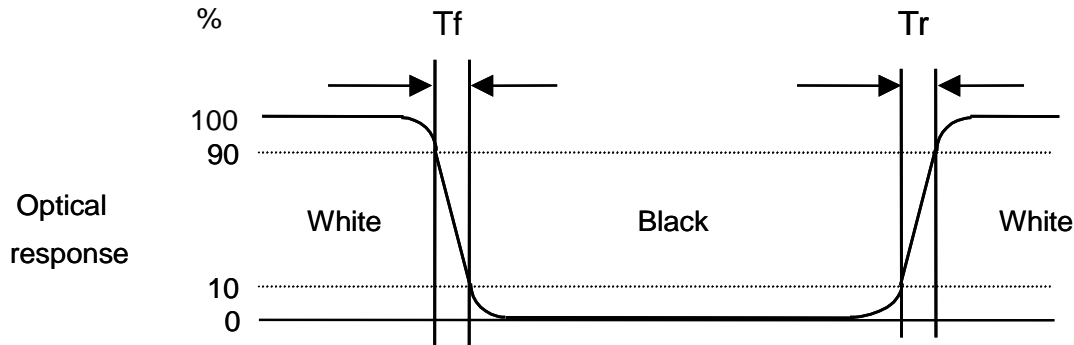

Note 7: Definition of viewing angle

Viewing angle is the measurement of contrast ratio ≥ 10 , at the screen center, over a 180° horizontal and 180° vertical range (off-normal viewing angles). The 180° viewing angle range is broken down as below: 90° (θ) horizontal left and right, and 90° (Φ) vertical high (up) and low (down). The measurement direction is typically perpendicular to the display surface with the screen rotated to its center to develop the desired measurement viewing angle.

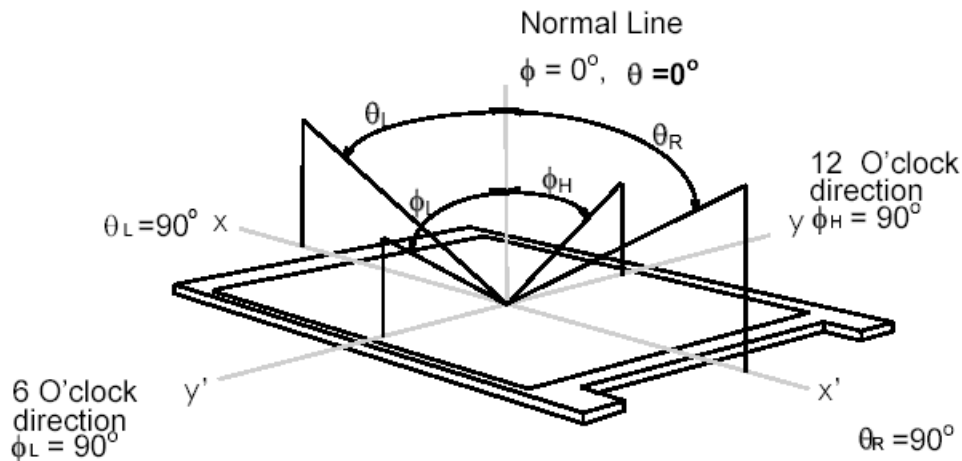

3. Functional Block Diagram

The following diagram shows the functional block of the 24 inches wide Color TFT-LCD Module:

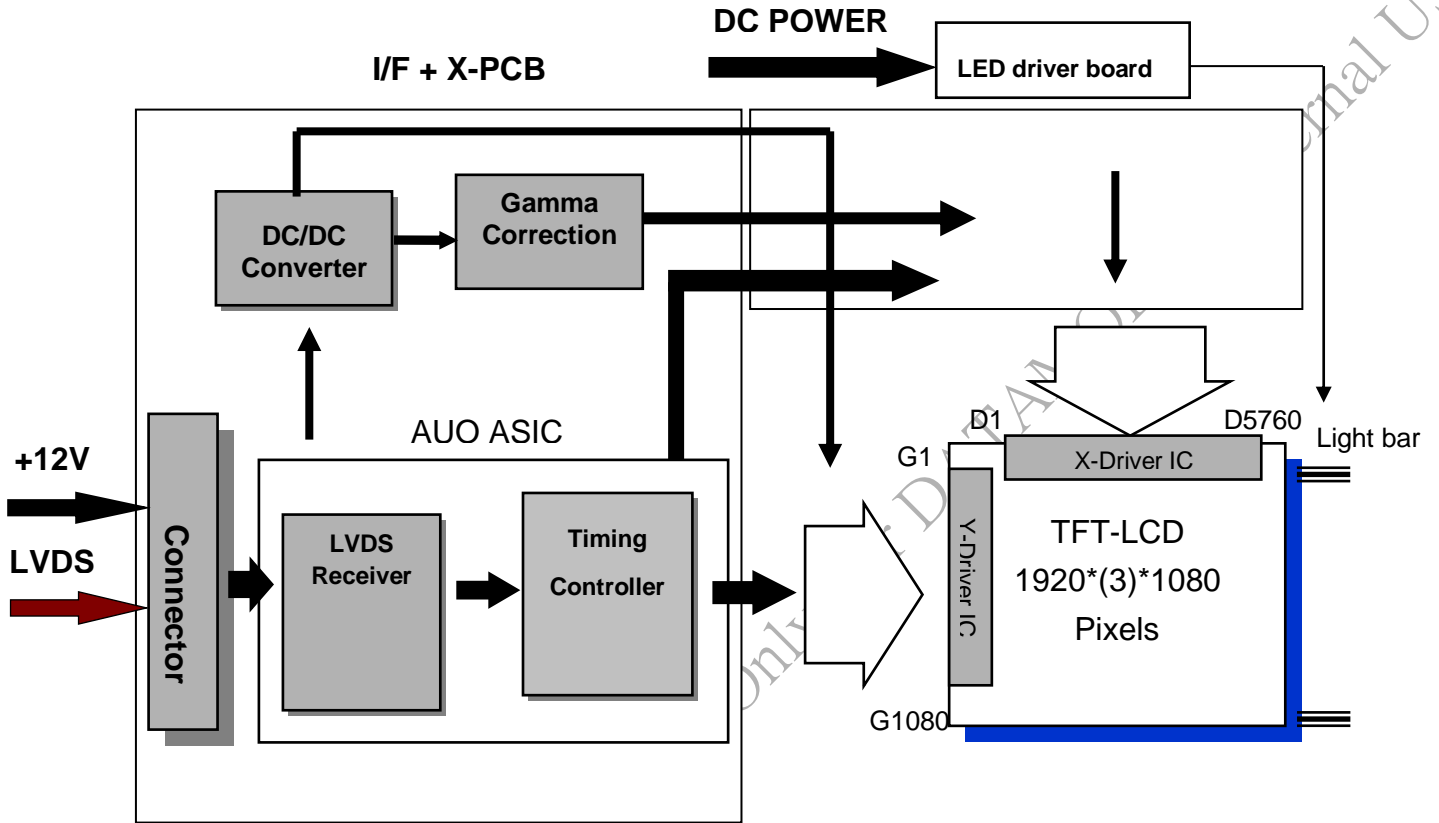

LVDS Connector: SIN SHENG (MSCK2407P30) or equivalent.
 BLU Driver Connector: CviLux (CI0114M1HR0-NH) or equivalent.

4. Absolute Maximum Ratings

4.1 TFT LCD Module

Item	Symbol	Min	Max	Unit	Conditions
Logic/LCD Drive Voltage	VDD	GND-0.3	13.2	[Volt]	Note 1,2

4.2 Backlight Unit

Item	Symbol	Min	Max	Unit	Conditions
LED Input Voltage	Vcc	GND-0.3	24.5	[Volt]	Note 1,2

4.3 Absolute Ratings of Environment

Item	Symbol	Min.	Max.	Unit	Conditions
Operating Temperature	TOP	-30	80	[°C]	Note 3
Operation Humidity	HOP	5	90	[%RH]	
Storage Temperature	TST	-30	80	[°C]	
Storage Humidity	HST	5	90	[%RH]	

Note 1: With in Ta (25°C)

Note 2: Permanent damage to the device may occur if exceeding maximum values

Note 3: For quality performance, please refer to AUO IIS(Incoming Inspection Standard).

Note 4: Maximum Wet-Bulb should be 39°C and no condensation.

Note 5: Function judged only.

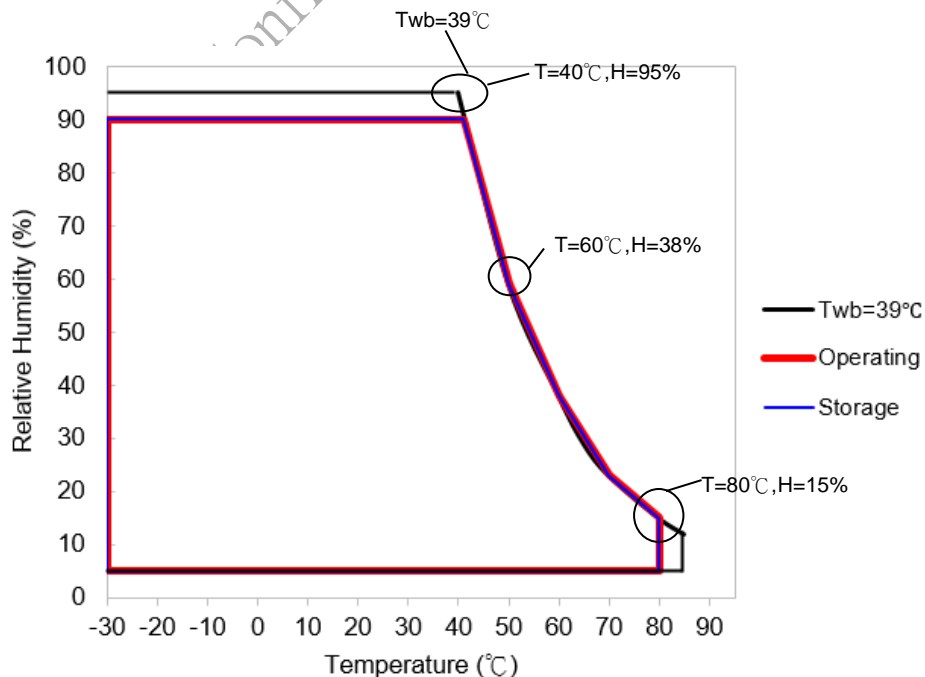

5. Electrical Characteristics

5.1 TFT LCD Module

5.1.1 Power Specification

Symbol	Parameter	Min	Typ	Max	Units	Remark
VDD	Logic/LCD Drive Voltage	10.8	12	13.2	[Volt]	± 10%
IDD	VDD Current	-	400	480	[mA]	VDD= 12V, All White Pattern At 60Hz
Irush	LCD Inrush Current	-	-	3	[A]	Note 1
PDD	VDD Power	-	4.8	5.76	[Watt]	VDD= 12V, All White Pattern At 60Hz

Note 1: Measurement condition:

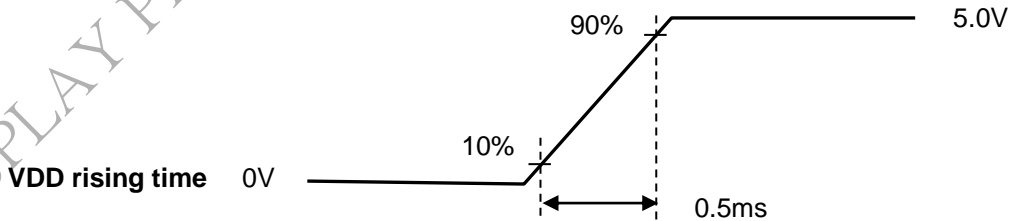
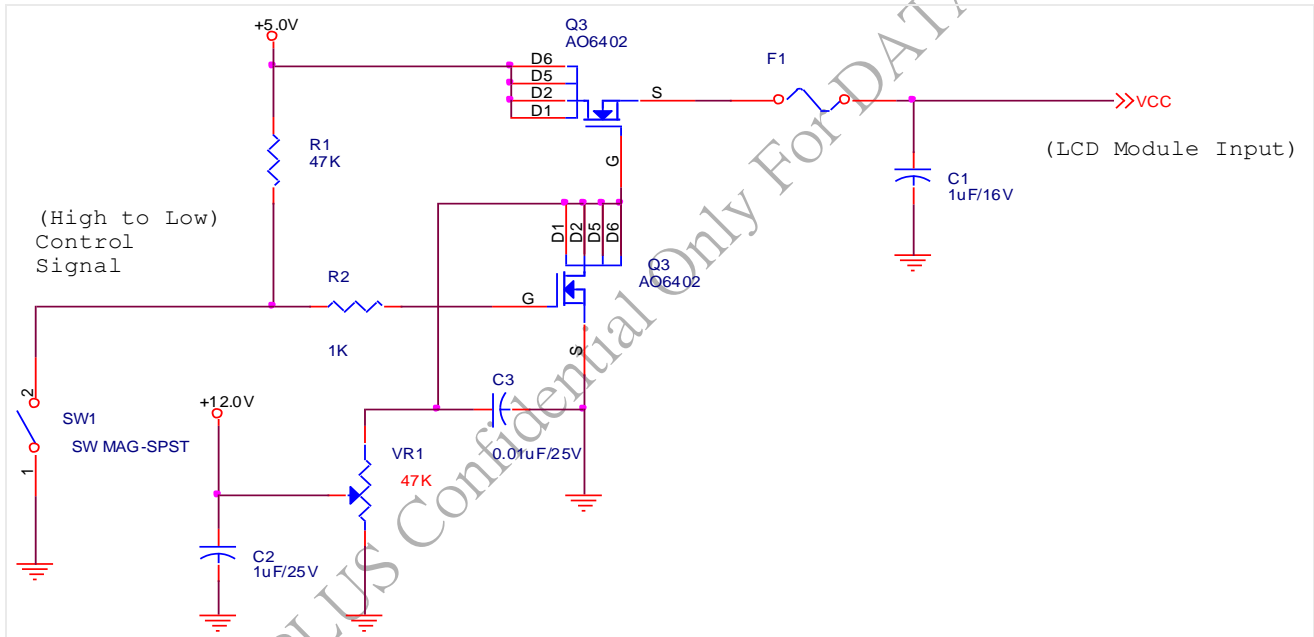

AUO Display+

5.1.2 Signal Electrical Characteristics

Input signals shall be low or Hi-Z state when VDD is off.

Symbol	Item	Min.	Typ.	Max.	Unit	Remark
VTH	Differential Input High Threshold	-	-	100	[mV]	VCM=1.2V
VTL	Differential Input Low Threshold	-100	-	-	[mV]	VCM=1.2V
VID	Input Differential Voltage	100	400	600	[mV]	
VICM	Differential Input Common Mode Voltage	0.3	-	1.25	[V]	VTH/VTL=±100mV

Note: LVDS Signal Waveform.

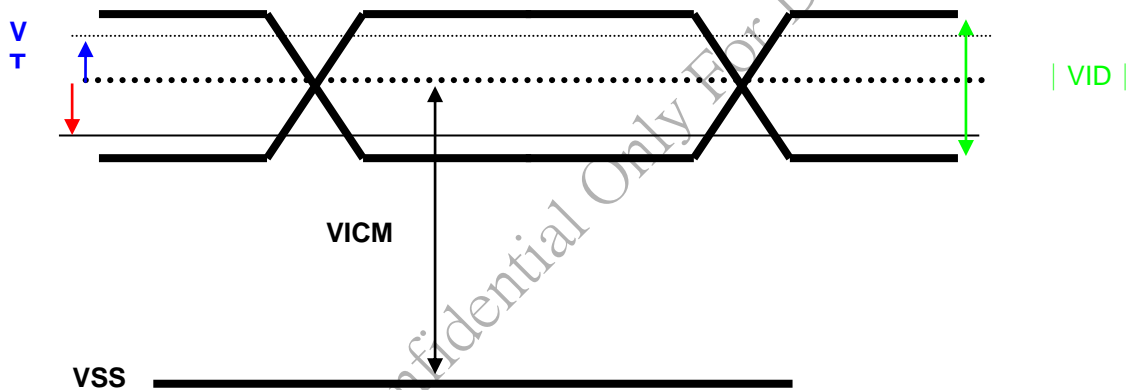

5.2 Backlight Unit

5.2.1 LED Driver

Following characteristics are measured under stable condition at 25°C (Room Temperature).

Symbol	Parameter	Min	Typ	Max	Units	Remark
Vcc	Input Voltage	23.5	24	24.5	Volt	
Ivcc	Input Current	-	2.13	2.55	A	100% Dimming
PLED	Power Consumption		51	61.2	Watt	100% Dimming
Irush	Inrush Current	-	4	5	A	
BL_EN	On Control Voltage	3	-	5.5	Volt	
	Off Control Voltage	0	-	0.5	Volt	
FPWM	PWM Dimming Frequency	200	-	20K	Hz	
	High Voltage	3.0	3.3	5.5	Volt	
	Low Voltage	0	-	0.5	Volt	
	Dimming Duty 200Hz~5KHz	5	-	100	%	
	Dimming Duty 5KHz~20KHz	15	-	100	%	
I _F	LED Forward Current		85		mA	Ta = 25°C
LTLED	LED Life Time	50,000	-	-	Hrs	Note 4

Note 1: Ta means ambient temperature of TFT-LCD module

Note 2: If module is driven by high current or at high ambient temperature & humidity condition. The operating life will be reduced.

Note 3: LED light bar structure: (7 strings x 12pcs / string =84pcs LED)

Note 4: Definition of life time: Brightness becomes to 50% of its original value. The minimum life time of LED unit is on the condition of I_F = 85 mA and 25±2°C (Room Temperature)

6.2 Signal Description

The module using a pair of LVDS receiver SN75LVDS82(Texas Instruments) or compatible. LVDS is a differential signal technology for LCD interface and high speed data transfer device. Transmitter shall be SN75LVDS83(negative edge sampling) or compatible. The first LVDS port(RxOxxx) transmits odd pixels while the second LVDS port(RxExxx) transmits even pixels.

PIN #	SIGNAL NAME	DESCRIPTION
1	RXinO0-	Negative LVDS differential data input (Odd data)
2	RXinO0+	Positive LVDS differential data input (Odd data)
3	RXinO1-	Negative LVDS differential data input (Odd data)
4	RXinO1+	Positive LVDS differential data input (Odd data)
5	RXinO2-	Negative LVDS differential data input (Odd data, H-Sync, V-Sync, DSPTMG)
6	RXinO2+	Positive LVDS differential data input (Odd data, H-Sync, V-Sync, DSPTMG)
7	GND	Power Ground
8	RxOCLKIN-	Negative LVDS differential clock input (Odd clock)
9	RxOCLKIN+	Positive LVDS differential clock input (Odd clock)
10	RXinO3-	Negative LVDS differential data input (Odd data)
11	RXinO3+	Positive LVDS differential data input (Odd data)
12	RXinE0-	Negative LVDS differential data input (Even data)
13	RXinE0+	Positive LVDS differential data input (Even data)
14	GND	Power Ground
15	RXinE1-	Negative LVDS differential data input (Even data)
16	RXinE1+	Positive LVDS differential data input (Even data)
17	GND	Power Ground
18	RXinE2-	Negative LVDS differential data input (Even data)
19	RXinE2+	Positive LVDS differential data input (Even data)
20	RxECLKIN-	Negative LVDS differential clock input (Even clock)
21	RxECLKIN+	Positive LVDS differential clock input (Even clock)
22	RXinE3-	Negative LVDS differential data input (Even data)
23	RXinE3+	Positive LVDS differential data input (Even data)
24	GND	Power Ground
25	NC	No connection (for AUO test only. Do not connect)
26	NC	No connection (for AUO test only. Do not connect)
27	NC	No connection (for AUO test only. Do not connect)
28	VDD	Power Supply Input Voltage
29	VDD	Power Supply Input Voltage
30	VDD	Power Supply Input Voltage

6.3 The Input Data Format

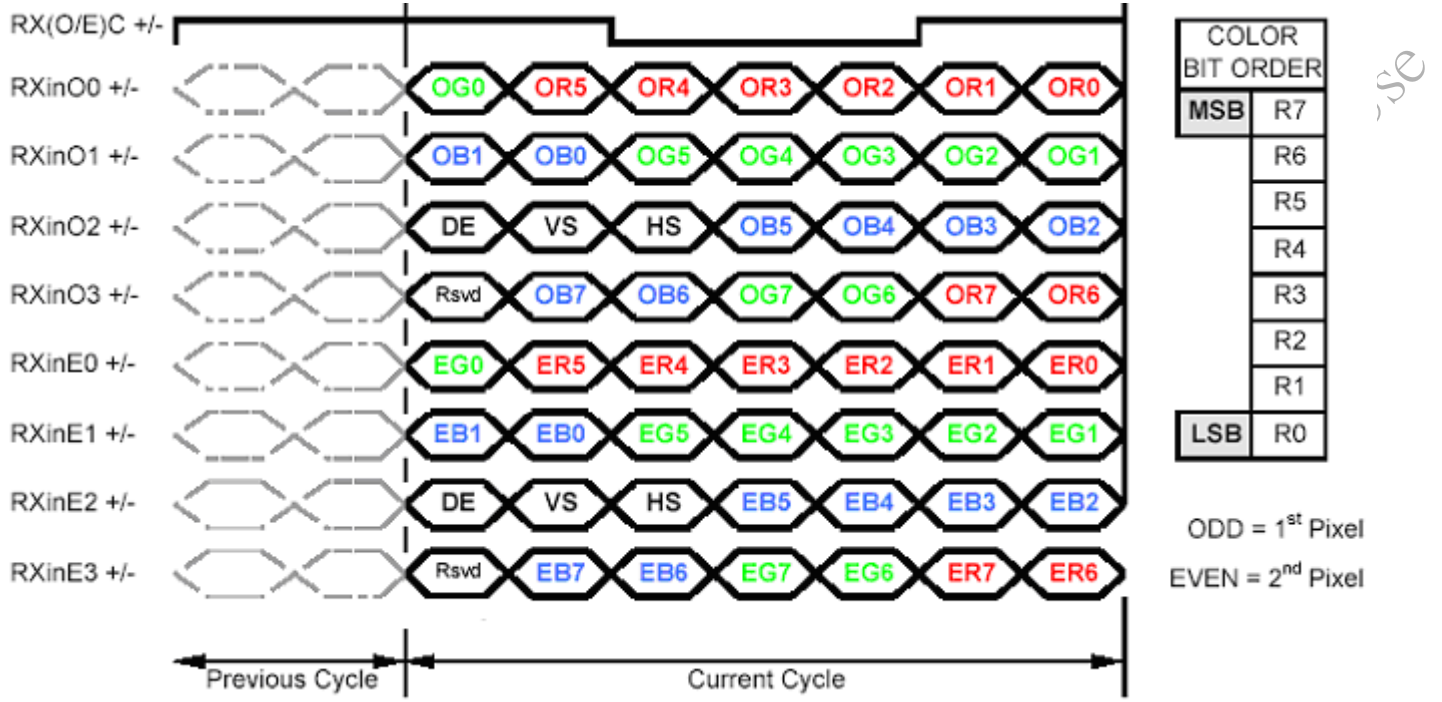

Note1: 8-bits signal input.
Note2: L:NS alike H:Thine alike

AUO DISPLAY PLUS Confidential Only

6.4 Interface Timing

6.4.1 Timing Characteristics

Signal	Item	Symbol	Min	Typ	Max	Unit
Clock	Frequency	$1/T_{Clock}$	40	72	83	MHz
Frame Rate	Frequency	$1/T_V$	50	60	75	Hz
Vertical Section	Period	T_V	1088	1120	2047	T_line
	Active	T_{VD}	1080	1080	1080	
	Blanking	T_{VB}	8	40	967	
Horizontal Section	Period	T_H	1034	1060	2047	T_clock
	Active	T_{HD}	960	960	960	
	Blanking	T_{HB}	74	100	1087	

Note: DE mode only.

6.4.2 Input Timing Diagram

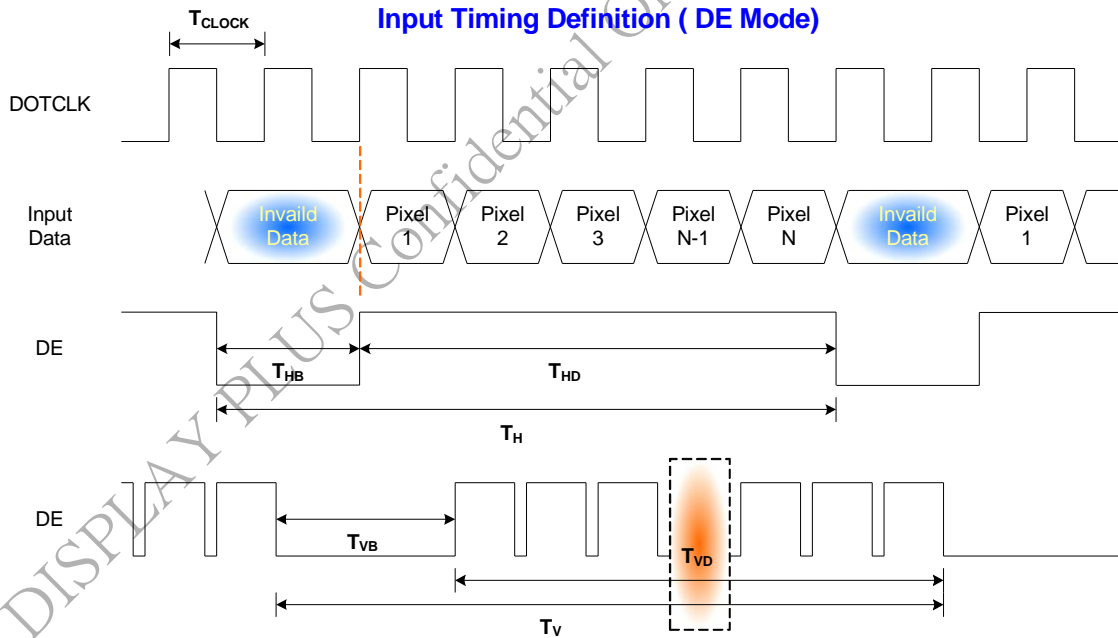

6.5 Power ON/OFF Sequence

VDD power and B/L on/off sequence is as below. Interface signals are also shown in the chart. Signals from any system shall be Hi-Z state or low level when VDD is off.

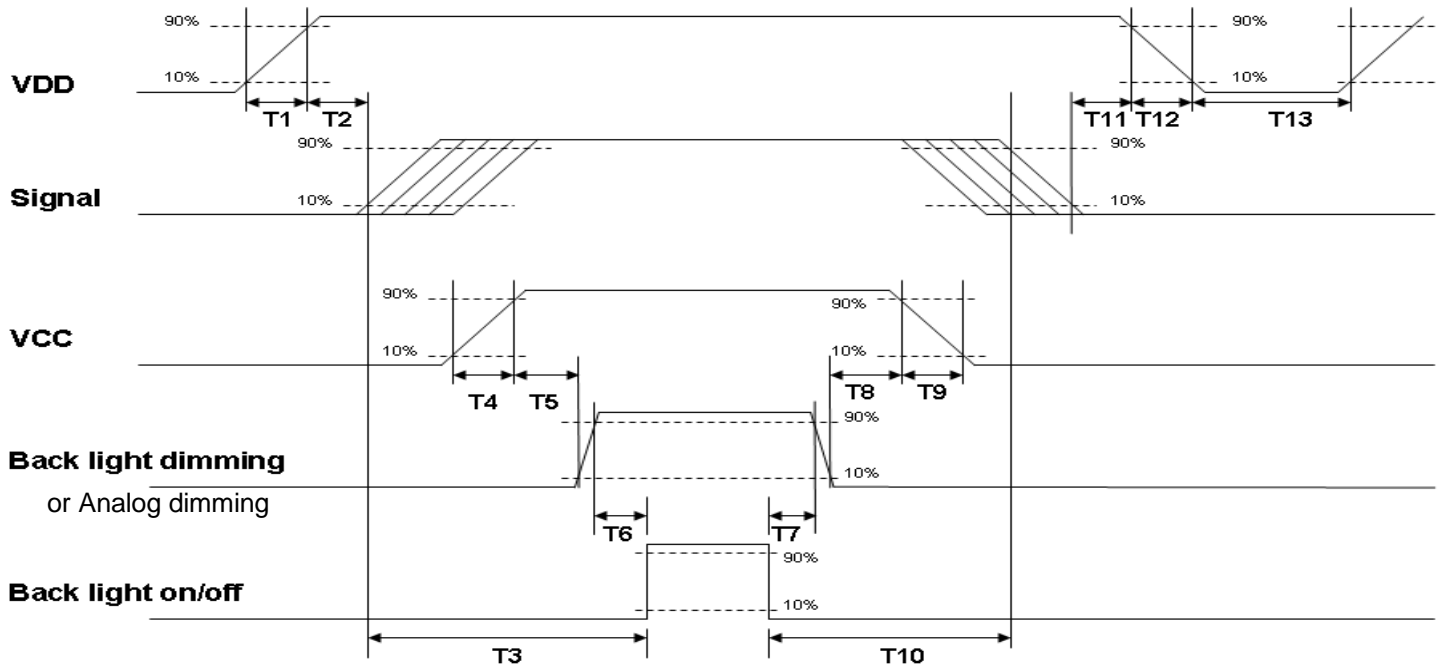

Power ON/OFF sequence timing

Parameter	Value			Units
	Min.	Typ.	Max.	
T1	0.5	--	10	[ms]
T2	30	40	50	[ms]
T3	200	--	--	[ms]
T4	0.5	--	10	[ms]
T5	10	--	--	[ms]
T6	10	--	--	[ms]
T7	0	--	--	[ms]
T8	10	--	--	[ms]
T9	--	--	10	[ms]
T10	110	--	--	[ms]
T11	0	16	50	[ms]
T12	--	--	10	[ms]
T13	1000	--	--	[ms]

The above on/off sequence should be applied to avoid abnormal function in the display. Please make sure to turn off the power when you plug the cable into the input connector or pull the cable out of the connector.

7. Connector & Pin Assignment

Physical interface is described as for the connector on module. These connectors are capable of accommodating the following signals and will be following components.

7.1 TFT LCD Module: LVDS Connector

Connector Name / Designation	Interface Connector / Interface card
Manufacturer	SIN SHENG or compatible
Type Part Number	SIN SHENG (MSCK2407P30) or equivalent.
Mating Housing Part Number	FI-X30HL (JAE) or compatible

Pin#	Signal Name	Pin#	Signal Name
1	RxOIN0-	2	RxOIN0+
3	RxOIN1-	4	RxOIN1+
5	RxOIN2-	6	RxOIN2+
7	GND	8	RxOCLKIN-
9	RxOCLKIN+	10	RxOIN3-
11	RxOIN3+	12	RxEIN0-
13	RxEIN0+	14	GND
15	RxEIN1-	16	RxEIN1+
17	GND	18	RxEIN2-
19	RxEIN2+	20	RxECLKIN-
21	RxECLKIN+	22	RxEIN3-
23	RxEIN3+	24	GND
25	NC	26	NC
27	NC	28	VDD
29	VDD	30	VDD

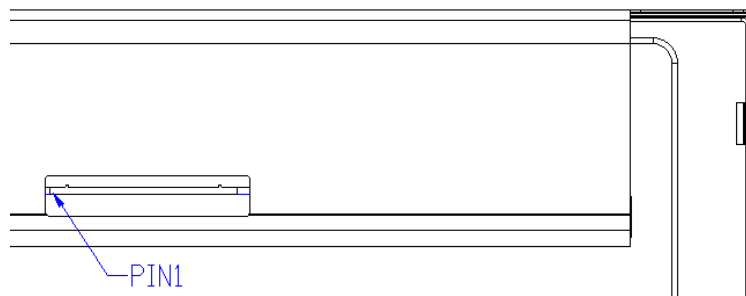

7.2 Backlight Unit: LED Connector

Connector Name / Designation	LED Connector
Manufacturer	CviLux
Connector Model Number	CI0114M1HR0-NH
Mating Housing Part Number	PHR-14 or compatible

Pin #	Symbol	Pin Description
1	VDD	Power +24V
2	VDD	Power +24V
3	VDD	Power +24V
4	VDD	Power +24V
5	VDD	Power +24V
6	GND	GND
7	GND	GND
8	GND	GND
9	GND	GND
10	GND	GND
11	NC	Do not connect
12	EN	Enable(0V:disable, 2.5~5V:Enable)
13	Dimming	PWM; duty 10%~ 100%
14	NC	Do not connect

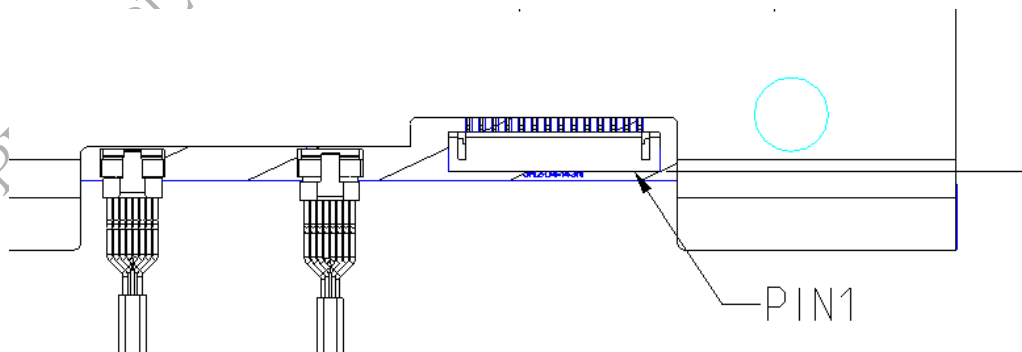

8. Reliability Test

Environment test conditions are listed as following table.

Items	Required Condition	Note
Temperature Humidity Bias (THB)	Ta= 50°C, 80%RH, 300hours	
High Temperature Operation (HTO)	Ta= 80°C, 300hours	
Low Temperature Operation (LTO)	Ta= -30°C, 300hours	
High Temperature Storage (HTS)	Ta= 80°C, 300hours	
Low Temperature Storage (LTS)	Ta= -30°C, 300hours	
Vibration Test (Non-operation)	Acceleration: 1.5 Grms Wave: Random Frequency: 10 - 200 Hz Duration: 30 Minutes each Axis (X, Y, Z)	
Shock Test (Non-operation)	Acceleration: 50 G Wave: Half-sine Active Time: 20 ms Direction: ±X, ±Y, ±Z (one time for each Axis)	
Drop Test	Height: 46 cm, package test	
Thermal Shock Test (TST)	-20°C/30min, 60°C/30min, 100 cycles	
On/Off Test	On/10sec, Off/10sec, 30,000 cycles	
ESD (Electro Static Discharge)	Contact Discharge: ± 8KV, 150pF(330Ω) 1sec, 8 points, 25 times/ point.	1
	Air Discharge: ± 15KV, 150pF(330Ω) 1sec 8 points, 25 times/ point.	
Altitude Test	Operation:10,000 ft Non-Operation:30,000 ft	

Note 1: According to EN61000-4-2, ESD class B: Some performance degradation allowed. No data lost Self-recoverable. No hardware failures.

Note2:

- Water condensation is not allowed for each test items.
- Each test is done by new TFT-LCD module. Don't use the same TFT-LCD module repeatedly for reliability test.
- The reliability test is performed only to examine the TFT-LCD module capability.
- To inspect TFT-LCD module after reliability test, please store it at room temperature and room humidity for 24 hours at least in advance.
- No function failure occurs.

9. Mechanical Characteristics

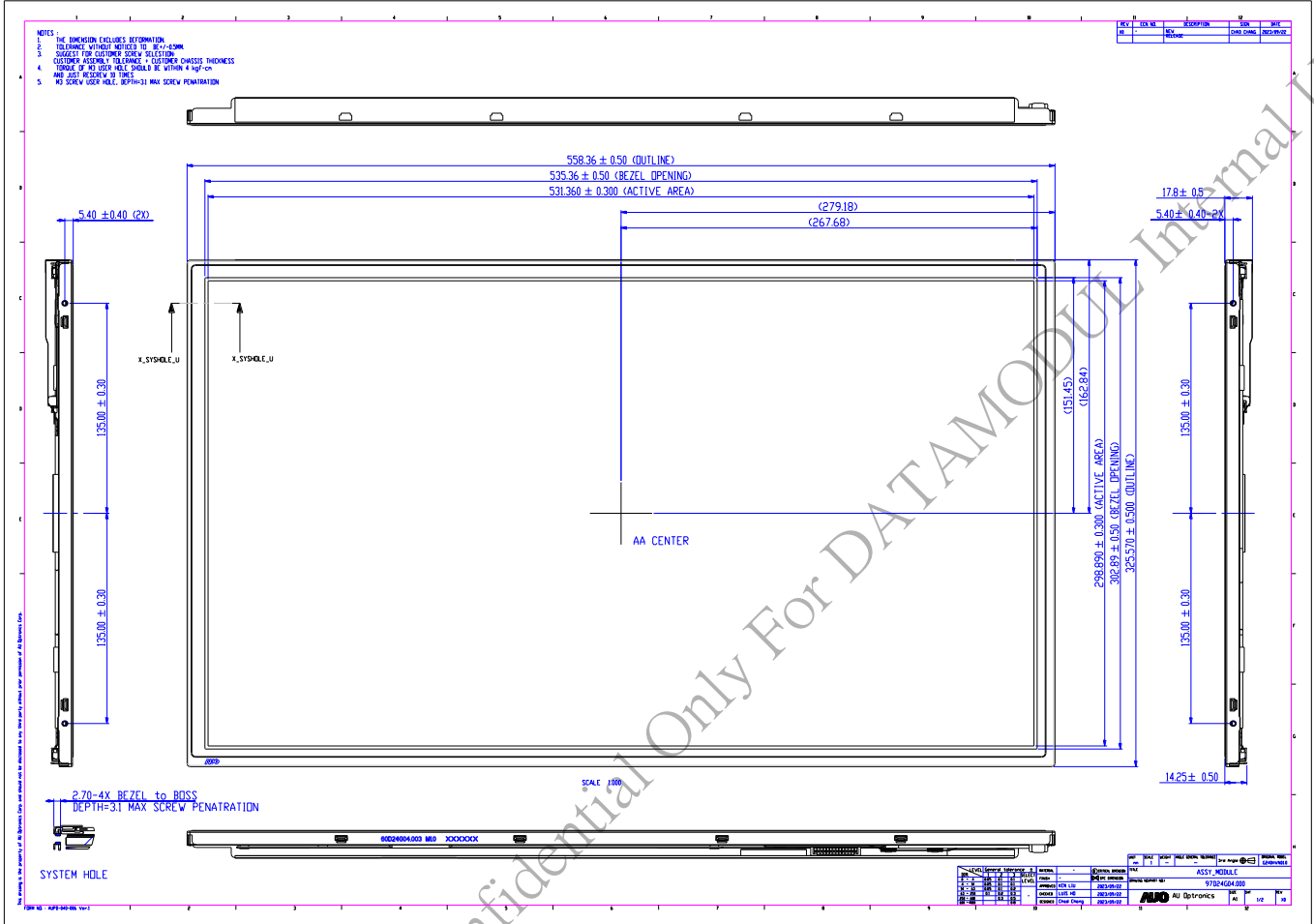



AUO Display+

Product Specification

AUO-General
G240HVN01.0

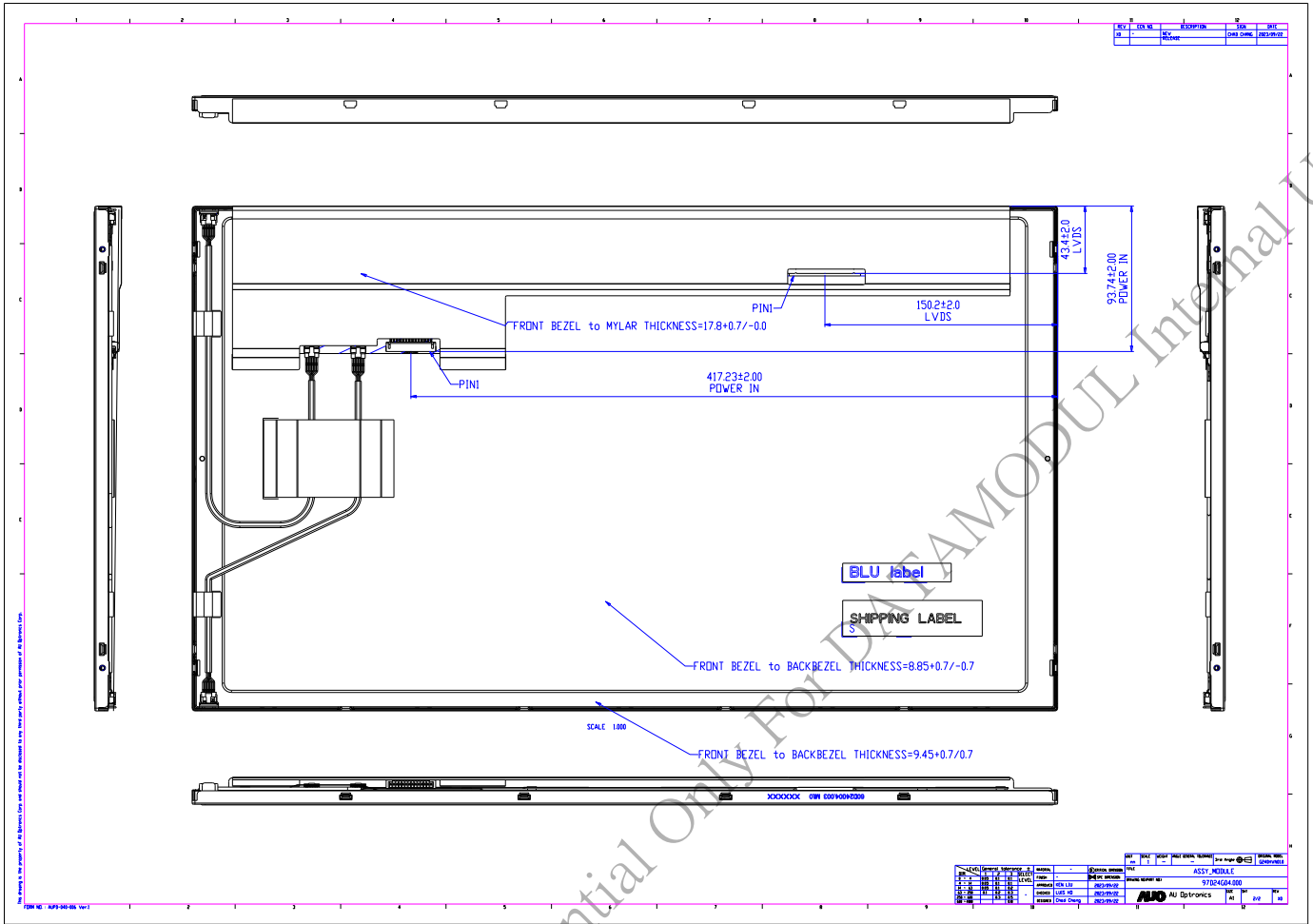

AUO DISPLAY PLUS Confidential Only For Internal Use

AUO Display+

10. Label and Packaging

10.1 Shipping Label (on the rear side of TFT-LCD display)

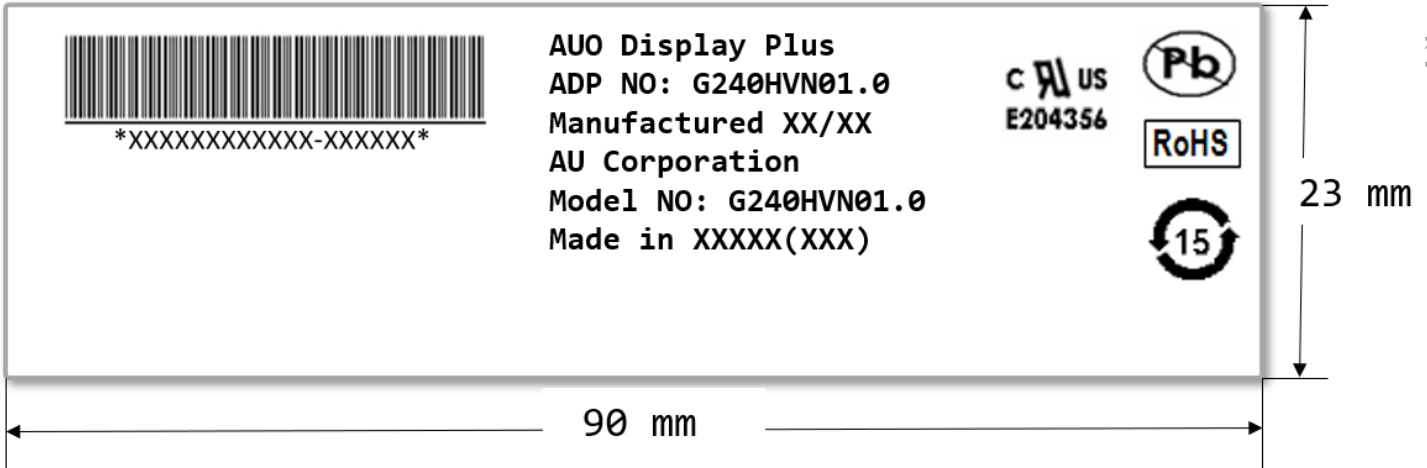

10.2 Carton Package

- The outside dimension of carton is 413 x 282x 661 (mm).
- 8 pieces per carton box.
- 2*4 boxes per layer. By air, 2 layer / pallet. By sea, refer packing documents. Pallet size (not include carton boxes): 1150 mm * 840 mm * 132 mm

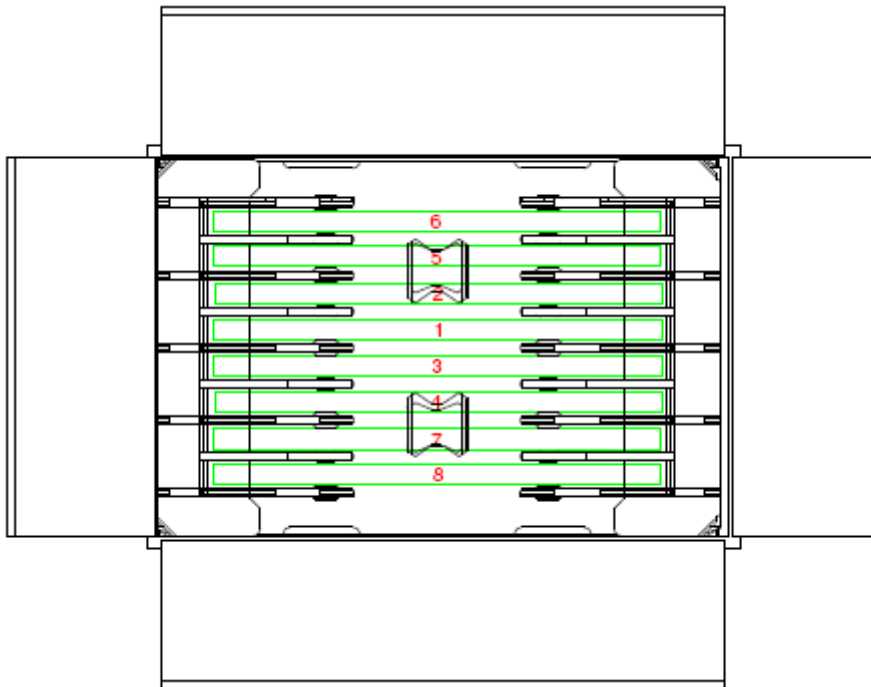



AUO Display+

Product Specification

AUO-General
G240HVN01.0

11. Safety

11.1 Sharp Edge Requirements

There will be no sharp edges or comers on the display assembly that could cause injury.

11.2 Materials

11.2.1 Toxicity

There will be no carcinogenic materials used anywhere in the display module. If toxic materials are used, they will be reviewed and approved by the responsible AUO toxicologist.

11.2.2 Flammability

The printed circuit board will be made from material rated 94-V1 or better. The actual UL flammability rating will be printed on the printed circuit board.

11.3 Capacitors

If any polarized capacitors are used in the display assembly, provisions will be made to keep them from being inserted backwards.

11.4 International Safety Standard Compliance

The TFT-LCD module will satisfy all requirements for compliance to:IEC/UL 62368-1

AUO DISPLAY PLUS Confidential Only For DATA MODUL Internal Use

DATA MODUL

Passion Displayed



All good things come in threes:

With **Hardware**, **Software** and **Services**, we realise unique display solutions that turn your ideas into reality.

www.data-modul.com

