



SPECIFICATION



SFGF829001-01

2.9" - 376 x 960 - MIPI

Version: 1.0

Date: 02.11.2022

Note: This specification is subject to change without prior notice

www.data-modul.com

Customer Name : --**Customer P/N : --****Unicorn P/N : UNC-SFGF829001-01****Customer Approval:**

- Approved for sample making.
- Approved for pilot production. Please specify minimum quantity (if any) _____ pcs
- Approved for mass production.

Customer Signature and Date:**Unicorn Internal Approval:**

Written By (Electrical)	Written By (Mechanical)	Checked By (R&D)	Approved By	
			R&D	QA
YC. Wang	SQ. Kuang			

REVISION HISTORY:

Rev	Date	Description	Written By	Approved By
1.0	2-Nov.-2022	New release .	Wangyucheng	LiShuangBing



CONTENTS

- 1.0 GENERAL SPECIFICATION**
- 2.0 PRODUCT NUMBERING SYSTEM**
- 3.0 OUTLINE DRAWING**
- 4.0 INTERFACE PIN DESCRIPTION**
- 5.0 ABSOLUTE MAXIMUM RATINGS**
- 6.0 ELECTRO-OPTICAL CHARACTERISTICS**
- 7.0 ELECTRO-OPTICAL CHARACTERISTICS**
- 8.0 BACKLIGHT SPECIFICATION**
- 9.0 RELIABILITY SPECIFICATION**
- 10.0 ENVIRONMENTAL SPECIFICATION**
- 11.0 PACKAGING SPECIFICATION**
- 12.0 GENERAL PRECAUTIONS FOR USING LCD MODULES**
- 13.0 MANUFACTURING DATECODING**
- 14.0 MANUFACTURER CONTACT**
- 15.0 APPENDIX**

1.0 GENERAL SPECIFICATION

Item	Contents	Unit
Display Mode	2.86" TFT Transmissive/IPS/Normally Black	-
Module outer dimension	28.81 x 76.0 x 1.95 (Excluded FPC length)	mm
Pixel Size	0.135(H) x 0.135(V)	mm
Effective display area	26.51 X 67.68	mm
Number of dots	376RGB(H)×960(V)	dots
Viewing direction	Free	O'clock
Pixel Arrangement	RGB Vertical Stripe	-
Backlight	LED white backlight	-
Driver IC	ST7701S-G5	-
Interface type	MIPI interface	-
Number Of Colors	16.7M	-
Operating temperature	-20 ~ 70	°C
Storage temperature	-30 ~ 80	°C

Remarks: Normal operating condition is temperature 15~35°C, humidity 45%~75%RH, atmospheric pressure 86~106kPa.

2.0 PRODUCT NUMBERING SYSTEM**UNC - S F G F 829001 - 01**

(1) (2) (3) (4) (5) (6) (7)

(1) One of product brand name for Unicorn Electronic (Shenzhen) Co Ltd

(2) Custom-made LCD module

(3) Display type (T: TN, S: STN/FSTN/FFSTN/ASTN, H: HTN, V: PMVA, D: DSTN, C: CSTN, F: TFT, B: Bistable, P: Plastic LCD, R: Other)

(4) Controller/driver package type (G: COG, T: TCP, F: COF, B: COB, N: Not applicable)

(5) Interface connection type (F: FPC/COF, H: Heatseal, Z: Zebra connector, P: Pin, T: TAB, C: Connector, N: Not applicable)

(6) Serial number

(7) Product revision

4.0 INTERFACE PIN DESCRIPTION

Pin No.	Symbol	Pin Description
1	GND	Ground
2	VCC	Power supply voltage
3	IOVCC	Driver IC Digital I/O Power Supply
4	RESET	Reset Signal Input Pin
5	GND	Ground
6	D1P	MIPI-DSI Positive polarity of low voltage
7	D1N	MIPI-DSI Negative polarity of low voltage
8	GND	Ground
9	CLKP	MIPI DSI CLOCK+
10	CLKN	MIPI DSI CLOCK-
11	GND	Ground
12	DOP	MIPI DSI DATA0+
13	DON	MIPI DSI DATA0-
14	GND	Ground
15	TE	Tearing effect signal
16	LEDA	LED backlight +
17	NC	No connection
18	LEDK	LED backlight -
19	NC	No connection
20	NC	No connection
21	NC	No connection
22	NC	No connection
23	NC	No connection
24	NC	No connection
25	GND	Ground

5.0 ABSOLUTE MAXIMUM RATINGS (Ta = 25°C, Vss = 0 V)

Parameter	Symbol	Min	Typ.	Max	Unit
Power Voltage	VDD	-0.3	-	4.6	V
	VDDIO	-0.3	-	4.6	V

Remarks: It is a normal characteristics that display may show some transitional optical imperfection when display is continuously running at extreme low and high temperature limit. Such transitional imperfection will disappear and resume back to normal characteristics within 24 hours when temperature returns back to room temperature. This transitional imperfection has no impact on display functionality and reliability for its nominal usage state as stated at item 1.0.

6.0 ELECTRICAL CHARACTERISTICS (Ta = 25°C, Vss = 0 V)

Parameter	Symbol	Min	Typ.	Max	Unit
Supply voltage for logic	VDD	2.5	2.8	3.3	V
I/O power supply	VDDIO	1.65	1.8	3.3	V
Input voltage	V _{IH}	0.7VDDIO	-	VDDIO	V
	V _{IL}	0	-	0.3VDDIO	V
Output voltage	V _{OH}	0.8VDDIO	-	VDDIO	V
	V _{OL}	0	-	0.2VDDIO	V
LCM supply current	I _{LCM}	-	45	68	mA

7.0 ELECTRO-OPTICAL CHARACTERISTICS

No	Item	Symbol	Condition	Min.	Typ.	Max.	Unit	Note	
1	Response Time	T _{ON} +T _{off}	$\theta = \phi = 0^\circ$	-	30	40	ms	(a)	
2	Contrast Ratio	CR	$\theta = \phi = 0^\circ$	800	1200	-	-	(c)	
3	Viewing Angle (CR ≥ 10)	3:00	$\phi = 0^\circ$	60	80	-	Deg	(b)	
		9:00	$\phi = 180^\circ$	60	80	-	Deg		
		12:00	$\phi = 90^\circ$	60	80	-	Deg		
		6:00	$\phi = 270^\circ$	60	80	-	Deg		
4	Brightness on LCM	L _{LCM}	$\theta = 0^\circ$ $\phi = 0^\circ$ 25 °C	240	280	--	cd/m ²	(d)	
5	Color Chromaticity (Center point of LCM) (CIE1931)	White	Wx	$\theta=0^\circ$ $\phi=0^\circ$ Ta=25°C	0.263	0.313	0.363	-	-
			Wy		0.282	0.332	0.382	-	-
		Red	Rx		0.548	0.598	0.648	-	-
			Ry		0.307	0.357	0.407	-	-
		Green	Gx		0.301	0.351	0.401	-	-
			Gy		0.533	0.583	0.633	-	-
		Blue	Bx		0.092	0.142	0.192	-	-
			By		0.043	0.093	0.143	-	-
6	NTSC			53.2%					

Remarks:

- 1) EOC data above is measured using DMS-501 display measurement system.
- 2) Brightness data is measured using photometer Topcon BM-7.

Note(a): Definition of Response Time

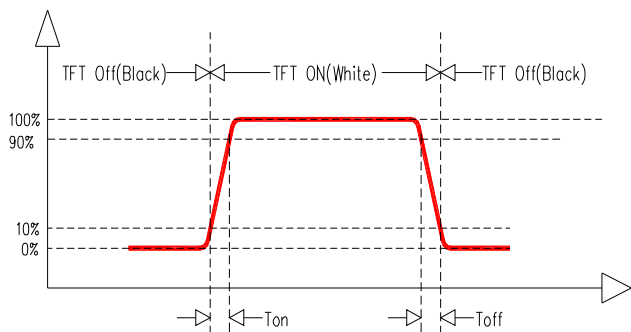

Note (b): Definition of Viewing Angle

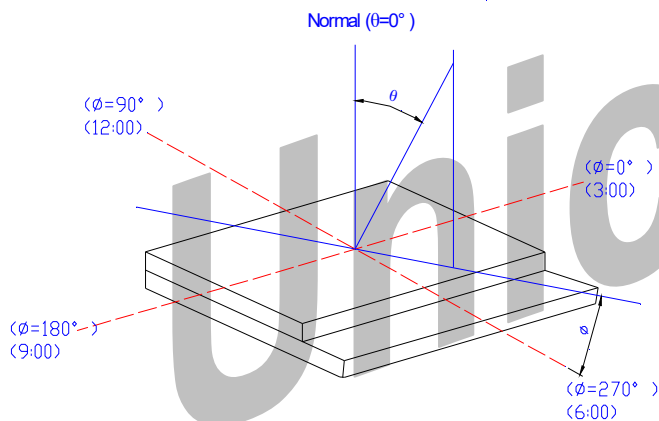

Note (c): Definition of Contrast Ratio

$$CR = \text{Brightness at all pixels "White"} / \text{Brightness at all pixels "Black"}$$

Note (d): backlight driving condition: If=180mA

Luminance measuring point: Center of the dot matrix under white pattern

measuring setup as below figure:

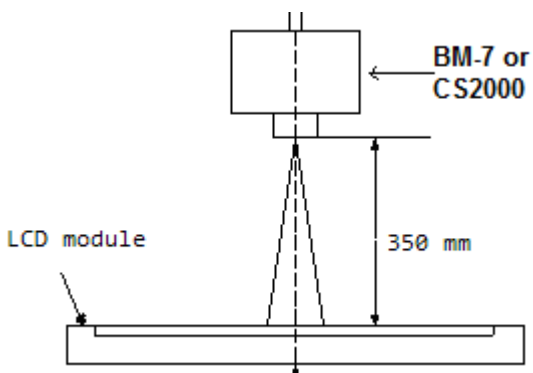

8.0 BACKLIGHT SPECIFICATION

8.1 LED Backlight Electrical-optical characteristics

Item of backlight characteristics	Symbol	Min	Typ	Max	Unit	Condition
Forward voltage	V _f	11.6	12.4	13.2	V	1.If=20mA, T=25°C 2. Aperture:1°,5 Points 3.Average=min/max*100%
Number of LED	-	4			Piece	-
Connection mode	S/P/M	4 Series			-	-

Remarks: chromaticity and luminance data are measured using photometer Topcon BM-7A.

9.0 RELIABILITY SPECIFICATION

9.1 Reliability Test Conditions

No	Test Item	Test Conditions
1	High temperature storage	80°C, 240hrs
2	High temperature operation	70°C, 240hrs
3	Low temperature storage	-30°C, 240hrs
4	Low temperature operation	-20°C, 240hrs
5	High temperature humidity	60°C, 90%RH, 240hrs
6	Temperature cycling storage	-30±2°C(30min) ~ 25°C(5min) ~ 80±2°C(30min), 10Cycle.
7	Vibration Test((on packaging)	Frequency:10-55Hz , Amplitude: 1.5mm , x,y,z every direction for 0.5 hour
8	Drop test (on packaging)	80cm height free fall (6 sides, 1 corner, 3edges) each once

Remarks:

- 1) For operation test, above specification is applicable when test pattern is changing during entire operation test.
- 2) Inspections after reliability tests are performed when the display temperature resumes back to room temperature.
- 3) It is a normal characteristic that some display abnormality can be seen during reliability test. If the display abnormality can recover as normal condition within 24 hours at room temperature, there is no permanent destruction over the display. The display still possesses its functionality and considered as acceptable after reliability tests.

9.2 Failure Judgment Criteria

After the reliability tests above, test sample shall be let return to room temperature and humidity for at least 4 hours before final tests are carried out.

Item	Acceptance Criteria
Electrical characteristic	No electrical short and open. Increase in current consumption is less than 2 times of initial value.
Mechanical characteristic	Within mechanical and drawing specification
Optical characteristic	Within appearance standard as specified in this specification. Contrast ratio change & ON-transmission value shall not less than 50% of initial value.

10.0 ENVIRONMENTAL SPECIFICATION

This product is designed, manufactured and compliant to below RoHS standard:

- | | |
|---|-------------------|
| 1. Cadmium and Cadmium Compounds | Less than 100ppm |
| 2. Hexavalent Chromium Compounds | Less than 1000ppm |
| 3. Lead and Lead Compounds | Less than 1000ppm |
| 4. Mercury and Mercury Compounds | Less than 1000ppm |
| 5. Polybrominated Biphenyls (PBBs) | Less than 1000ppm |
| 6. Polybrominated Diphenyl ethers (PBDEs) | Less than 1000ppm |
| 7. Butyl benzyl phthalate (BBP) | Less than 1000ppm |
| 8. Bis (2-ethylhexyl)phthalate (DEHP) | Less than 1000ppm |
| 9. Dibutyl phthalate (DBP) | Less than 1000ppm |
| 10. Diisobutyl phthalate(DIBP) | Less than 1000ppm |

11.0 PACKAGING SPECIFICATION

Product No.	UNC-SFGF829001-01	Recycle	No
Product Name	LCD Module		
Quantity / each box	192 pcs	Box Material	Paper Carton
Outer carton Box size	42.0cm × 32.0cm × 29.0cm	Box Type	New
Quantity / inner box Quantity /outer box	16 × 6 × 2 = 192pcs	Weight	- kg

There are 24 pcs LCD per each anti-static plastic plate.

There are 7 layer plastic plates per each inner carton box. [Note\(1\)](#)

There are 2 inner carton box per each outer carton box.

[Note\(1\)](#): 6pcs trays put products and stacked + 1pcs trays as a cap.

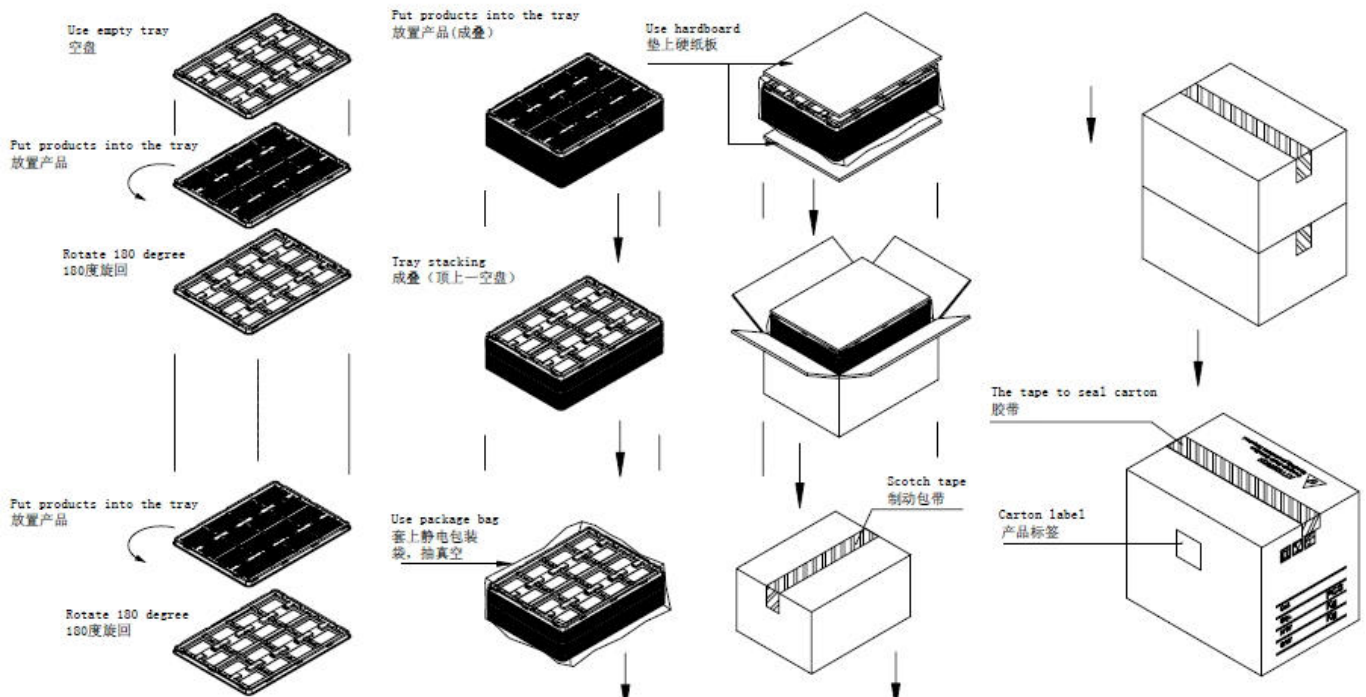

12.0 GENERAL PRECAUTIONS FOR USING LCD MODULES

Handling Precaution	Operation Precautions
<ul style="list-style-type: none"> No strong mechanical shock. LCD may be broken because it is made out of glass. Do not work on PCB. PCB may be cracked or damaged. Do not bend or process metal bezel positioning tab. LCD maybe shifted and LCD-PCB interconnection may be damaged, Do not scratch. Polarizer is soft material and can be easily scratched. Liquid crystal may leak when LCD/LCM is broken. Please wash your hands if you touch the liquid crystal. Wear gloves when handling LCD/LCM to avoid damage to LCD/LCM. Please do not touch electrodes with bare hands to avoid any contamination on connection. 	<ul style="list-style-type: none"> Viewing angle can be adjusted by varying driving voltage, V_0 or V_{op}. Display performance may vary or show abnormal electro-optical performance when viewed at angle beyond the specified viewing angle range. Display color may change under extreme temperature. This is not destructive symptom and display color will resume back to normal when temperature goes back to normal temperature. Driving voltage shall be kept within the specified range as stated in this product specification. Over-voltage may shorten the LCD/LCM lifetime. No DC voltage to LCD/LCM. Electrical characteristics and reliability of LCD/LCM will deteriorate under DC. Please control the DC content in application driving circuit. Avoid using the same display pattern for long time (continuous ON segment). It is a normal phenomena observed for passive driven display where image retention is observed when LCD is displayed with same pattern over 1 hour under temperature $> 55^{\circ}\text{C}$. Customer is advised to design application software where display pattern will be changed from time to time, or using the N-line inversion function comes with the display driver IC. If the LCM is using master-slave configuration, customer is strongly recommended to use external V_0. If the LCM comes with MTP/OTP function, customer is recommended to use this MTP/OTP function for the best optical performance.
<p style="text-align: center;">Soldering Precaution on LCD/LCM</p> <ul style="list-style-type: none"> Use soldering iron with proper grounding and no AC leakage. Temperature at tip of soldering iron: $330\pm 10^{\circ}\text{C}$ Type of solder: lead-free solder with resin flux fill. Soldering time: $< 3\text{sec}$. Soldering on LCD/LCM I/O terminal only. Do not apply force on the LCD metal pin when soldering. Metal pin connection to LCD terminal will be damaged or loosen by this external force under soldering temperature. Do not solder and de-solder for more than 3 times because metal pin connection or soldering pads will be damaged. 	
<p style="text-align: center;">Static Electricity</p>	<p style="text-align: center;">FPC cleanness</p>
<ul style="list-style-type: none"> Avoid static electricity. Please have proper ESD control and ground the human body and any electrical tools when assembling the LCD/LCM. Static electricity will be generated when peeling the protective film. It is a normal behavior that LCD/LCM will response to the static charges generated and will resume back to normal condition slowly. Peeling off the protective film in a correct way is very important to reduce the static electricity and its influence on LCD/LCM. It's recommended that the static electricity is controlled less than 1KV by using ion fan and peeling off protective film slowly and in 45° angle, etc. <div style="border: 1px solid black; padding: 5px; margin-top: 10px;"> <div style="display: flex; justify-content: space-between;"> <div style="border: 1px solid black; padding: 2px; width: 45%;"> <p>Speed: Slowly peeling off the protective film to make sure static electricity less than 1KV.</p> </div> <div style="border: 1px solid black; padding: 2px; width: 45%;"> <p>Angle: direction of removing protective film is $45^{\circ}\pm 15^{\circ}$</p> </div> </div> <div style="margin-top: 5px;"> <p style="border: 1px solid black; padding: 2px; width: fit-content;">Ionized air to reduce static electricity less than 1KV.</p>  </div> </div>	<ul style="list-style-type: none"> If ACF bonding is applied at customer side between FPC and PCB, cleaning on FPC and PCB bonding area (just before bonding) is a must to reduce risk of bonding reliability (eg bonding delamination/spring back phenomenon, low pull strength etc) <p style="text-align: center;">Long-term Storage Conditions</p> <ul style="list-style-type: none"> Store LCD/LCM in dark area and keep LCD/LCM away from direct sunlight and fluorescent light. Store LCD/LCM under temperature range of $0\sim 35^{\circ}\text{C}$ and room humidity of $50\sim 60\%RH$. Possible V_{op} adjustment might be needed at customer side after prolong storage over 1 year from date of manufacturing.

13.0 MANUFACTURING DATECODING

All LCD/LCM will have an indication on lot number to show the manufacturing date of the LCD/LCM. Such indication can be a label stuck on the LCD/LCM or ink-injected code. Lot number is having below format:

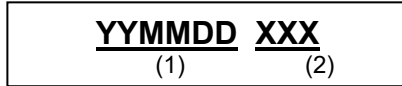

- (1) YYMMDD- Year, month and day where the LCD/LCM is manufactured.
(2) XXX – unique serial number

14.0 MANUFACTURER CONTACT:

UNICORN ELECTRONIC (SHENZHEN) COMPANY LIMITED

No.214 of AnLan Road,Zhang Keng Jing Village,GuanLan Street,
Bao'an District, ShenZhen, Guangdong, People's Republic of China.
Postal Code 518110.

Telephone No : 86-755-2782 7222

Fax No : 86-755-2782 5120

15.0 APPENDIX

15.1 Functional testing pattern

Below test patterns will be used at all LCM functional tests at mass production stage. Acceptance of a product during inspection will be judged based on these test patterns only. Customer should notify Unicorn if different test patterns being used at customer side to ensure same testing platform between Customer and Unicorn, especially on those defects (flickering, image sticking, cross-talk, black/white line) which are pattern-dependent. These test patterns are by default agreed by both Customer and Unicorn, unless notified by Customer to revise such test patterns. If the defect listed in above description is seen in below pattern, LCD module should be judged as NG and vice versa.

1) Scene pattern:



2) Blue pattern:



3) Green Pattern:

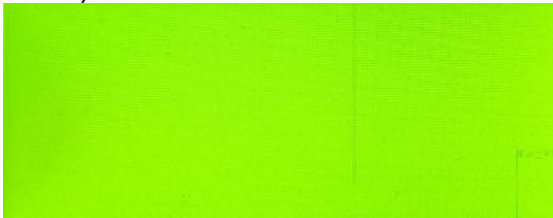

4) Red Pattern :



5) Gray Scale Pattern:

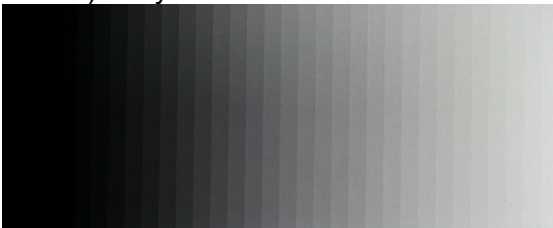

6) Black pattern:



7) White pattern:

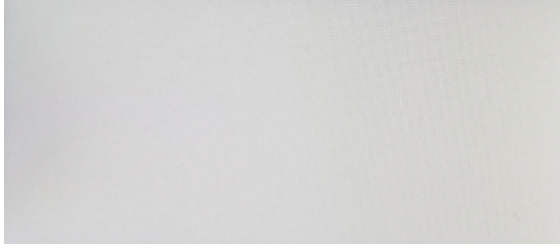

Unicorn



ALL TECHNOLOGIES. ALL COMPETENCIES. ONE SPECIALIST.



DATA MODUL AG
Landsberger Straße 322
DE-80687 Munich
Phone: +49-89-56017-0

DATA MODUL WEIKERSHEIM GMBH
Lindenstraße 8
DE-97990 Weikersheim
Phone: +49-7934-101-0



More information and worldwide locations can be found at

www.data-modul.com